

TS-CHUTE

Transnorm Safeglide Chute

The Transnorm Safeglide® Spiral Chute exhibits a sophisticated and controlled method of delivering most products from a higher elevation down a lower level. These chutes are available in four (4) sizes to accommodate a large range of products. Other degrees available. Contact Transnorm.

- Multiple Sizes and Configurations
 - Center Column with Glass wrapped around it
 - Gel Coat Surface
- F.O.B. Arlington, Texas

transnorm
your best move



CONFIGURATIONS:

Counter - Clockwise

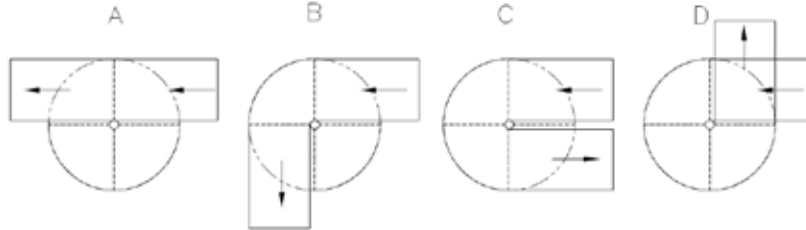

Clockwise

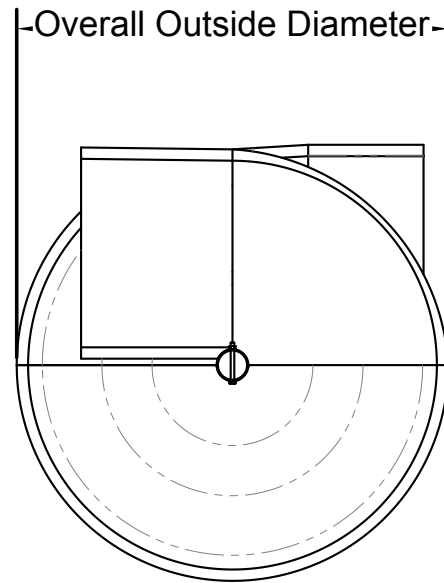
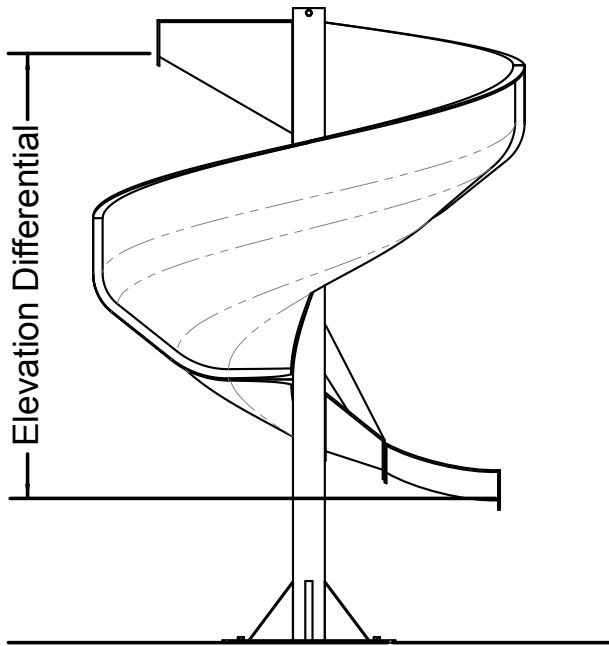
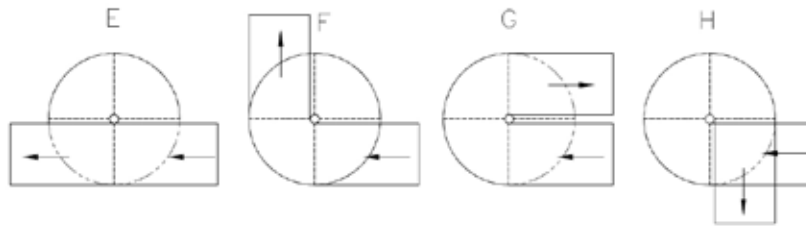

• STANDARD SPECIFICATIONS

MATERIAL- 3/8" thick Fiberglass with a Gel Coat surface

COLUMN- 6.6" Diameter, Steel Column

ACCUMULATION- Allowed. Chute is self-starting once bottom is cleared out.

EXIT SWOOP- Standard exit to allow smooth discharge.

BASE PLATE- 3' x 3' square base plate with leveling bolts and Anchor holes.

• OPTIONAL EQUIPMENT

EXTENSIONS- 12ga. Galv. Infeed and Exit Extension's available upon need.

CUSTOM COLORS- Available (Contact factory), Paint chip may be required.