

25-PVEZD

Heavy Duty Accumulating Conveyor (Zero Pressure Accumulating Type)

The Model 25-PVEZD is a Poly-V Belt driven live roller conveyor designed for zero pressure accumulation of products. This conveyor is designed to handle loads such as pallets, drums, containers, etc. Products may be accumulated in zones and released upon request.

- EZDrive™ System (Individual zone drive)
- EZLogic® Accumulation System
- Poly-V Belt Driven Rollers
- Shaft Mounted Drive
- Adjustable HSN-Type Floor Supports Available

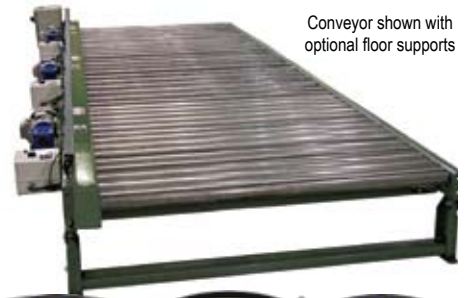

Conveyor shown with optional floor supports



U.S. Patent Numbers
5,862,907 • 7,243,781 • 7,591,366 • 6,860,381
Other Patents Pending.

OAW—3 in., 4 in., and 6 in. Roller Centers.

Conveying Surface	27 3/4"	29 3/4"	31 3/4"	33 3/4"	35 3/4"	37 3/4"	39 3/4"	41 3/4"	43 3/4"	45 3/4"	47 3/4"	49 3/4"	51 3/4"	53 3/4"	55 3/4"	57 3/4"	59 3/4"	61 3/4"	63 3/4"
Between Rail Width	31"	33"	35"	37"	39"	41"	43"	45"	47"	49"	51"	53"	55"	57"	59"	61"	63"	65"	67"
Overall Frame Width	34 1/4"	36 1/4"	38 1/4"	40 1/4"	42 1/4"	44 1/4"	46 1/4"	48 1/4"	50 1/4"	52 1/4"	54 1/4"	56 1/4"	58 1/4"	60 1/4"	62 1/4"	64 1/4"	66 1/4"	68 1/4"	70 1/4"
Weight Per Foot 3" Centers	145	151	157	163	169	175	181	187	193	199	205	211	217	223	229	235	241	247	253
Weight Per Foot 4" Centers	109	114	119	124	129	134	139	144	149	154	159	164	169	174	179	184	189	194	199
Weight Per Foot 6" Centers	84	87	90	93	96	99	102	105	108	111	114	117	120	123	126	129	132	135	138

- Total Weight = (Number of Zones x 30) + (OAL x Weight per Foot)
- All weights in catalog are conveyor weights only. Accessories, crating, etc. are not included.
- Motors will slave a maximum of 40 rollers, 20 rollers per side.

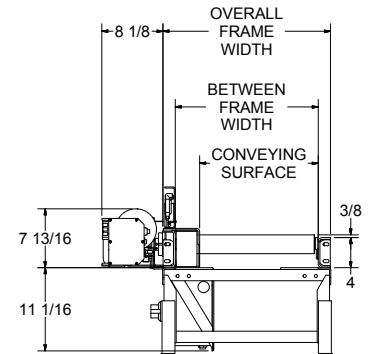
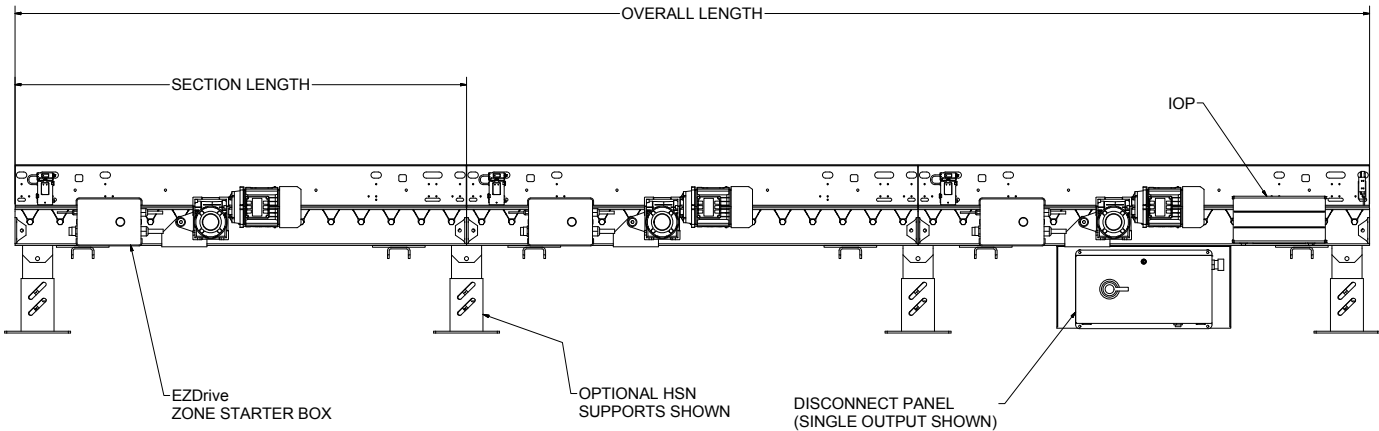

• STANDARD SPECIFICATIONS

BED—Roller bed with 2 1/2 in. dia. x 11 ga. unplated rollers spaced every 3, 4, or 6 in. Tread rollers mounted in 4 in. x 4 ga. formed channel on side opposite chain guard and 5 in. x 4 ga. formed channel on chain guard side. Bolted together with butt couplings.

POLY-V BELT—J-profile, 8 rib roller to roller

GUARD—Formed steel guards totally enclose drive belts.

BEARINGS—Sealed, pre-lubricated ball bearings.

EZDrive™ System—Shaft mounted gearmotor located near center of each zone. 1/2 HP - 3 PH 60 Hz. Totally enclosed fan cooled. 230/460 V (specify voltage). Includes EZDrive™ Disconnect Panel. Power is distributed zone to zone through pluggable cordsets. Power is connected from the starter box to the motor via "SO" type cord. Please contact factory if local code requires other than the standard power distribution techniques described.

ACCUMULATION ZONES—4 in. roller centers, 32 in. to 120 in. on 4 in. increments. 3 in. and 6 in. roller centers, 30 in. to 120 in. on 6 in. increments. Frame length changes with zone length.

EZLogic™ ZONE CONTROLLER—Located in each zone (Retro-Reflective). NEMA 1, 2, IP 62. UL Approved.

IOP—Provides 27VDC, 100 watt power for EZLogic™ accumulation system - contains slots for 4 input/output boards. Should be located near disconnect panel. See chart for maximum quantity of zones. Requires 120VAC or 230VAC single phase input.

CONVEYING SPEED—Constant 28 FPM.

CAPACITY—Maximum load per linear foot of conveyor 250 lbs. Maximum unit load 3000 lbs per zone. Zones longer than 6 ft. may require an additional floor support depending on product load.

FLOOR SUPPORTS—Now supplied as optional equipment.

DISCONNECT PANEL	230V	460V
	3 Ph. 60 Hz	3 Ph. 60 Hz
SINGLE OUTPUT	1-5 ZONES	1-10 ZONES
DUAL OUTPUT	6-10 ZONES	11-20 ZONES

† **Note:** Infeed Wake-Up Eye used only on terminating infeed end of conveyor. Not used when connecting to upstream EZLogic™ conveyor through power supply isolation cable.

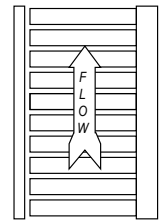
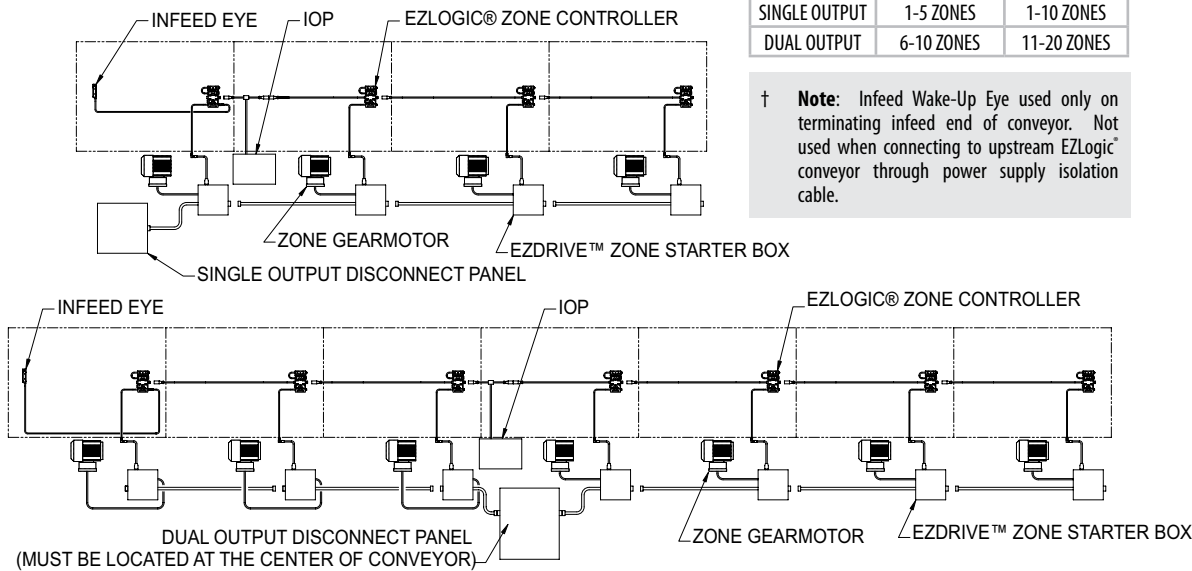

RH CHAIN GUARD (STANDARD)

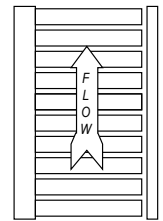

LH CHAIN GUARD

EZLogic™ ACCUMULATION SYSTEM

Hytrol's EZLogic™, or "Electronic Zero-pressure Logic" Accumulation System, combines the sensing accuracy of photo-electronics with discrete electronic logic control without the use of a PLC or pneumatic logic components. The EZLogic™ Accumulation System provides many features including:

Zero-Pressure Accumulation of Product

Zone Stop - Function is built in. Any zone may be transformed into a workstation by connecting a dry contact switching device to the auxiliary port of the EZLogic™ Zone Controller. This feature is always used at the discharge end of the conveyor line, and may be used at any other location where a zone stop is required.

Dynamic Zone Allocation - Automatically adjusts the conveyor's zone length to accommodate the length of the product being conveyed. Improves conveyor efficiency and system flexibility.

Sleep Feature - Stops tread rollers from turning when no product is present, reducing noise, reducing energy consumption and extending roller bearing life.

Unloading Zone Feature - Zone On Delay - Timer delays the zone immediately upstream from a removed load, preventing it from driving for a set time. This feature is ideal where loads are routinely removed from the conveyor with a lift truck.

Loading Zone Feature - Zone detects load being placed onto the conveyor with a fork truck and stops the zone from driving and automatically prevents any loads in zones upstream from entering loading area.

• OPTIONAL EQUIPMENT

FLOOR SUPPORTS—HSN Type floor supports are available with a wide range of adjustment. Specify top of belt or roller elevation. One support required at every bed joint and ends of conveyor. Holes in feet for lagging to floor. Knee braces recommended above HSN-6 support.

CONVEYING SPEED—Other constant and variable speeds available, contact factory.

GUARD RAIL - Angle type only

EZDrive™ System:

- Variable Frequency Drive-for adjusting conveying speed or adjusting acceleration and deceleration time.

EZLogic™ - See EZLogic™ Components Page.