

DCEZ-60

Drag Chain Conveyor

The Model DCEZ-60 is a two strand drag chain conveyor designed to handle pallets. With EZLogic® Zone Controller, pallets are accumulated with zero pressure, reducing the possibility of collision that may result in product damage.

- 2 Strand Design
- EZLogic® Accumulation System (Diffuse)
- 11 Widths
- Modular Assembly
- Adjustable DCS and DCDS-Type Floor Supports Available



U.S. Patent Numbers
5,862,907 • 7,243,781 • 7,591,366
Other Patents Pending.



OVERALL LENGTH "A"	FRAME WIDTH STRAND CENTERS	19 7/8"	22 7/8"	25 7/8"	28 7/8"	31 7/8"	34 7/8"	37 7/8"	40 7/8"	43 7/8"	46 7/8"	49 7/8"
12'		615	641	667	694	720	748	774	801	827	851	880
17'		797	832	868	905	941	979	1014	1051	1087	1121	1160
22'		979	1023	1069	1116	1162	1210	1254	1301	1347	1391	1440
27'		1161	1214	1270	1327	1383	1441	1494	1551	1607	1661	1720
32'	WEIGHTS (Lbs.)	1343	1405	1471	1538	1604	1672	1734	1801	1867	1931	2000
37'		1525	1596	1672	1749	1825	1903	1974	2051	2127	2201	2280
42'	weights based on 60" Inter.	1707	1787	1873	1960	2046	2134	2214	2301	2387	2471	2560
47'		1889	1978	2074	2171	2267	2365	2454	2551	2647	2741	2840
52'	Frame Lengths	2071	2169	2275	2382	2488	2596	2694	2801	2907	3011	3120
62'		2435	2551	2677	2804	2930	3058	3174	3301	3427	3551	3680
72'		2799	2933	3079	3226	3372	3520	3654	3801	3947	4091	4240
82'		3163	3315	3481	3648	3814	3982	4134	4301	4467	4631	4800
92'		3527	3697	3883	4070	4256	4444	4614	4801	4987	5171	5360
102'		3891	4079	4285	4492	4698	4906	5099	5301	5507	5711	5920

HOW IT WORKS

The conveyor is made up of drive, intermediate and tail sections on which two strands of #60 single pitch chain travel. Each strand is a continuous loop and driven by a common drive shaft. Hytrol's EZLogic® Zone Controllers sense product presence and control the accumulation and release of product from the zones. To accumulate products accumulation lift pads are activated which lift the product off of chain strands.

IMPORTANT NOTE:

Do not operate DCEZ in sleep or slug mode.

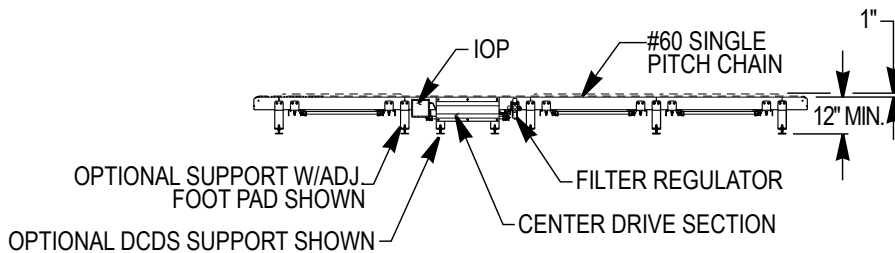
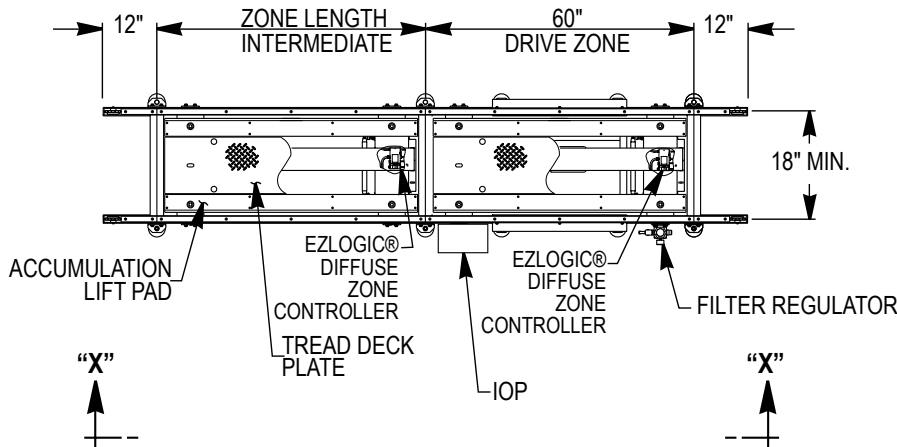

VIEW X-X



• STANDARD SPECIFICATIONS

CHAIN – #60 single pitch conveyor chain (straight sidebar).

CHAIN GUIDE – UHMW polyethylene.

FRAME – 6 in. x 7 ga. powder painted formed steel angle with 1 ½ in. x ¾ wall, chain support tube. 4 ga. formed coupling channels located at infeed and discharge ends of each module.

DRIVE SPROCKETS – Hardened #60 with 1 ¾ in. dia. steel shaft.

BEARINGS – Sealed, pre-lubricated, self aligning, ball bearings on drive.

EZLogic® ZONE CONTROLLER – Located in each zone (Diffuse). NEMA 1, 2, IP62. UL Approved.

ACCUMULATION ZONES – 36 in., 42 in., 48 in., 54 in., 60 in., and 66 in. long intermediate sections with EZLogic® Accumulation (Diffuse). Contact factory for other lengths. (Drive Section minimum 60 in. long.)

IOP – Provides 27VDC, 100 watt power for EZLogic® accumulation system - contains slots for 4 input/output boards. Requires 120VAC or 230VAC single phase input.

AIR REQUIREMENTS – Recommended working pressure 60 P.S.I. Free air consumption at 75 P.S.I. - .50 cu. ft. per actuation for 18" & 21" strand centers - 1.0 cu. ft. per actuation for 24 - 28 strand centers.

FILTER, REGULATOR – Supplied for main air supply line (½ in. NPT port). Includes pressure sensor.

MOTOR – 1 ½ HP – 230/460V – 3 PH. 60 HZ. gearmotor, located underneath in 5 ft. long module.

CONVEYING SPEED – 35 FPM.

CAPACITY – 12,000 lbs. maximum at 30 FPM (1 ½ HP maximum). NOT TO EXCEED CAPACITY IN CHART.

FLOOR SUPPORTS – Now supplied as optional equipment.

EZLOGIC® ACCUMULATION SYSTEM

Hytrol's EZLogic®, or "Electronic Zero-pressure Logic" Accumulation System, combines the sensing accuracy of photo-electronics with discrete electronic logic control without the use of a PLC or pneumatic logic components. The EZLogic® Accumulation System provides many features including:

Zero-Pressure Accumulation of Product

Zone Stop - Function is built in. Any zone may be transformed into a workstation by connecting a dry contact switching device to the auxiliary port of the EZLogic® Zone Controller. This feature is always used at the discharge end of the conveyor line, and may be used at any other location where a zone stop is required.

Dynamic Zone Allocation – Automatically adjusts the conveyor's zone length to accommodate the length of the product being conveyed. Improves conveyor efficiency and system flexibility.

Unloading Zone Feature - Zone On Delay – Timer delays the zone immediately upstream from a removed load, preventing it from driving for a set time. This feature is ideal where loads are routinely removed from the conveyor with a lift truck.

Loading Zone Feature – Zone detects load being placed onto the conveyor with a fork truck and stops the zone from driving and automatically prevents any loads in zones upstream from entering loading area.

LOAD CAPACITY CHART (Accumulated or Live)* @ 30 FPM		
HP	TOTAL LOAD (Lbs.)	
	UP TO 50'	UP TO 102'
1 ½	12,000	10,000

*Load capacities in accumulation mode are calculated assuming no more than half of the load will be moving at any time.



• OPTIONAL EQUIPMENT

FLOOR SUPPORTS – DCDS and DCS Type floor supports are available with a wide range of adjustment. Specify top of chain elevation. One support required at every bed joint and ends of conveyor. Holes in feet for lagging to floor.

CLOSED TAIL – Overall length will be affected.

MOTORS – Energy efficient, 1 ½ HP maximum.

CONVEYING SPEED – Speeds other than 30 FPM will require gearmotor change (contact factory).

ELECTRICAL MOTOR CONTROLS – Non-reversing magnetic starter – push-button stations.

EZLogic® – See EZLogic® Components Page.