

199-CRR

Chain Driven Live Roller Conveyor

The Model 199-CRR is a medium-duty chain driven live roller conveyor. The roll-to-roll chain drive makes this conveyor ideal for light to medium duty pallet handling or oily conditions which are not suitable for belt driven live roller.

- 11 Bed Widths
- Center Drive
- Reversible
- Chain Driven Rollers
- Adjustable MSN-Type Floor Supports Available



Conveyor shown with optional floor supports

Conveying Surface	12 ¼"	14 ¼"	16 ¼"	18 ¼"	20 ¼"	22 ¼"	24 ¼"	28 ¼"	30 ¼"	34 ¼"	36 ¼"
Between Rail Width	15"	17"	19"	21"	23"	25"	27"	31"	33"	37"	39"
Overall Frame Width	18"	20"	22"	24"	26"	28"	30"	34"	36"	40"	42"
Base Weight	145	150	155	160	165	170	175	185	190	200	205
Weight (Lbs.) Per Foot 4" Roller Centers	51	53	55	57	59	61	63	67	69	72	75
Weight (Lbs.) Per Foot 6" Roller Centers	46	47	49	51	52	54	55	59	60	63	65

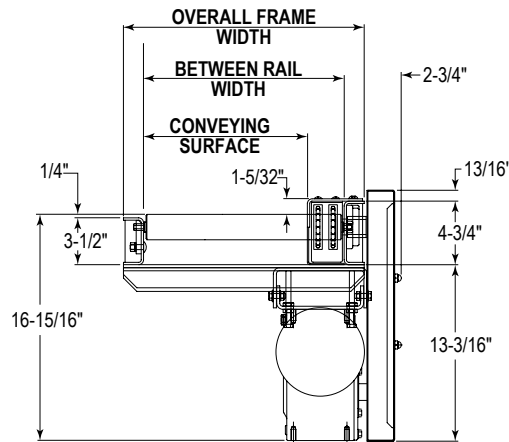
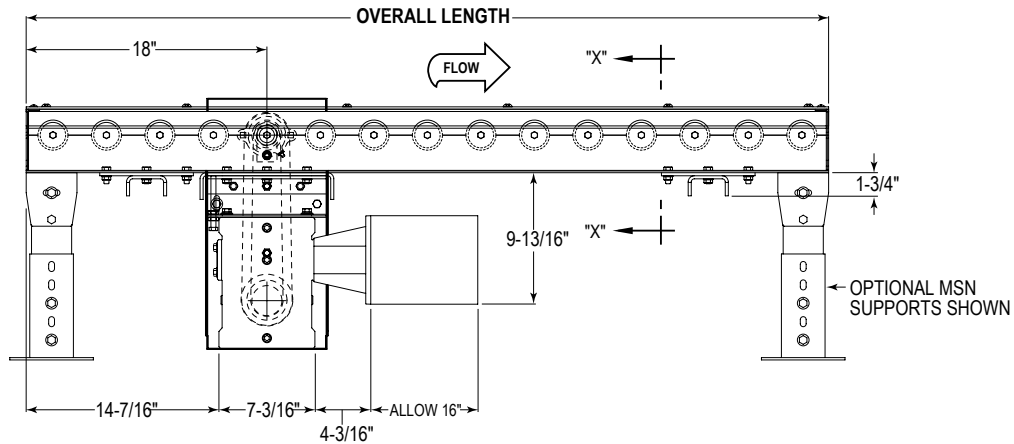

SECTION X-X



• STANDARD SPECIFICATIONS

BED—Roller bed with 1.9 in. x 9 ga. wall unplated tread rollers spaced every 4 in. or 6 in. mounted in 7 ga. powder painted formed steel channel frame bolted together with butt couplings.

CENTER DRIVE—Mounted underneath bed section.

ROLLER CHAIN—No. 40 roller-to-roller chain.

MOTOR DRIVE CHAIN—No. 60 chain.

CHAIN GUARD—Mounted to top of channel frame to totally enclose drive chain.

BEARINGS—Sealed, pre-lubricated ball bearings on drive roller shaft.

SPEED REDUCTION—Sealed worm gear C-Face speed reducer.

MOTOR—½ HP—208/230/460/575V—3 Ph. 60 Hz. Totally Enclosed C-Face.

CONVEYING SPEED—Constant 35 FPM.

CAPACITY—Maximum load per linear foot of conveyor 150 lbs. with supports on 10 ft. centers, 250 lbs. per ft. with supports on 5 ft. centers and 4 in. roller centers. NOT TO EXCEED capacity in charts.

FLOOR SUPPORTS—Now supplied as optional equipment.

LOAD CAPACITY CHART @ 35 FPM & 6" ROLLER CENTERS									
	OVERALL WIDTH	18" - 28"				30" - 42"			
	OVERALL LENGTH	25'		50'		25'		50'	
	SUPPORT CENTERS	5'	10'	5'	10'	5'	10'	5'	10'
HP	½	2250	2250	1250	1250	2000	2000	1000	1000
	1	5000	3750	3250	3250	5000	3750	3000	3000
	2	6250	3750	7250	7250	6250	3750	7000	7000



CHAIN GUARD REMOVED TO ILLUSTRATE ROLL TO ROLL DRIVE CHAIN.

WARNING: DO NOT OPERATE CONVEYOR WITH CHAIN GUARD REMOVED.

• OPTIONAL EQUIPMENT

FLOOR SUPPORTS—MSN Type floor supports are available with a wide range of adjustment. Specify top of belt or roller elevation. One support required at every bed joint and ends of conveyor. Holes in feet for lagging to floor. Knee braces recommended above MSN-6 support.

CONVEYING SPEED—Other constant and variable speeds. **NOTE:** Capacity affected with speed change.

SHAFT MOUNTED DRIVE—Requires shaft mounted gearmotor. Minimum elevation top of rollers 6 in.

O-RING DRIVE CHAIN—With sealed in lubricant (Recommended for applications that do not permit regular lubrication).

ROLLERS SET LOW—Tread rollers mounted in 4 ¾ in. x 10 ga. formed steel channel frame to form 1 in. high guard rails.

CHAIN CROSSOVER—Move driving chain from one side to opposite side.

GUARD RAILS—Adjustable Universal Channel Guard Rail, (both sides) fixed channel (both sides) or angle (one side). See Accessory section .

POLY-TIER SUPPORTS—36 in. to 120 in. support heights in 6 in. increments. Knee braces supplied.

CEILING HANGERS—½ in. dia. x 8 ft. long unplated rods fully threaded. Other lengths and galvanized rods available.

MOTORS—Energy efficient, single phase, brakemotor. 2 HP maximum.

ELECTRICAL CONTROLS—Non-reversing magnetic starters and push-button stations. AC variable frequency drive.