

25-CRRC

Chain Driven Live Roller Conveyor (Roll-to-Roll Type)

The Model 25/26-CRRC is a heavy-duty, chain driven roller curve conveyor commonly used in conjunction with the 25/26-CRR conveyor to carry heavy unit loads such as drums. Can be used in industries like bottling and steel manufacturing. Product orientation could be affected with straight roller curves.

- 16 Widths
- Reversible
- Chain Driven Rollers
- Can Be Slave-driven from 25-CRR
- Adjustable HSN-Type Floor Supports Available



Conveyor shown with optional floor supports

CONVEYING SURFACE WIDTH	BETWEEN RAIL WIDTH	OVERALL BED WIDTH	OUTSIDE RADIUS				INSIDE RADIUS				NO OF ROLLERS				WEIGHTS			
			30°	45°	60°	90°	30°	45°	60°	90°	30°	45°	60°	90°	30°	45°	60°	90°
15 3/4"	19"	22 1/4"	77 3/4"	65 1/8"	77 7/8"	71 1/2"	58 3/4"	46 1/8"	58 7/8"	52 1/2"	8	10	16	22	364	403	503	607
17 3/4"	21"	24 1/4"					56 3/4"	44 1/8"	56 7/8"	50 1/2"					374	414	517	628
19 3/4"	23"	26 1/4"					54 3/4"	42 1/8"	54 7/8"	48 1/2"					384	425	532	648
21 3/4"	25"	28 1/4"					52 3/4"	40 1/8"	52 7/8"	46 1/2"					393	436	547	669
23 3/4"	27"	30 1/4"	110"	102 1/2"	98 3/4"	95"	50 3/4"	38 1/8"	50 7/8"	44 1/2"	10	14	18	26	403	447	562	689
27 3/4"	31"	34 1/4"					79"	71 1/2"	67 3/4"	64"					478	567	657	858
29 3/4"	33"	36 1/4"					77"	69 1/2"	65 3/4"	62"					489	581	674	881
33 3/4"	37"	40 1/4"					73"	65 1/2"	61 3/4"	58"					512	609	707	928
35 3/4"	39"	42 1/4"	120"	112 1/2"	108 3/4"	105**	71"	63 1/2"	59 3/4"	56"	10	14	18	26	523	523	724	952
39 3/4"	43"	46 1/4"					67"	59 1/2"	55 3/4"	52"					546	651	757	999
43 3/4"	47"	50 1/4"					63"	55 1/2"	51 3/4"	48"					568	679	790	1046
47 3/4"	51"	54 1/4"					59"	51 1/2"	47 3/4"	44"					590	707	824	1092
49 3/4"	53"	56 1/4"	120"	112 1/2"	108 3/4"	105**	67"	59 1/2"	55 3/4"	52"	10	14	18	26	612	735	852	1137
51 3/4"	55"	58 1/4"					65"	57 1/2"	53 3/4"	50"					634	763	880	1182
53 3/4"	57"	60 1/4"					63"	55 1/2"	51 3/4"	48"					656	791	908	1227
55 3/4"	59"	62 1/4"					61"	53 1/2"	49 3/4"	46"					678	819	936	1272

All weights in catalog are conveyor weights only. Accessories, crating, etc., are not included

Note: Add 25% for 26 Rollers

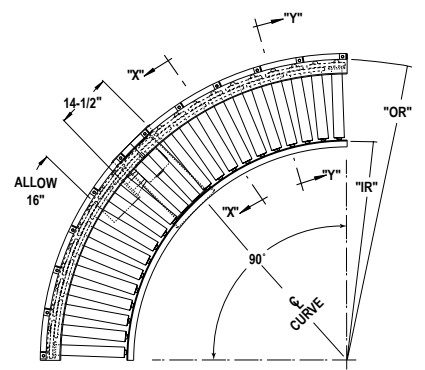
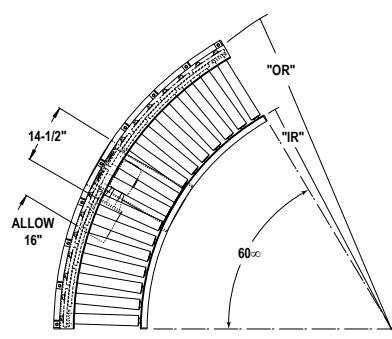
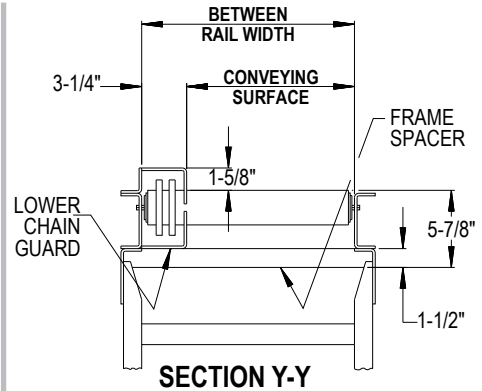
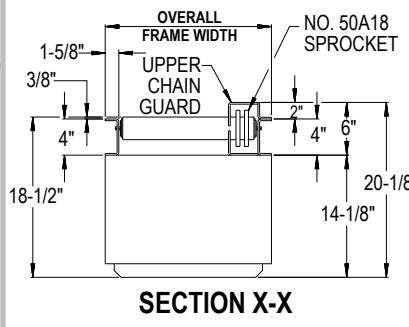
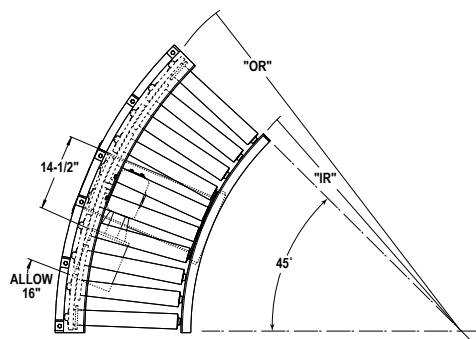
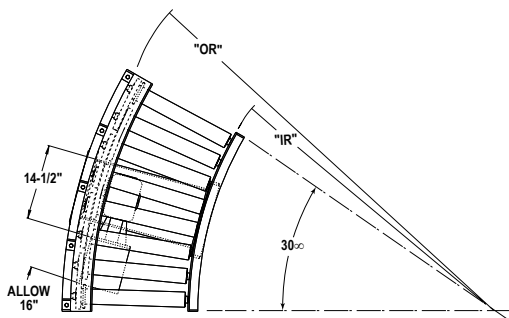
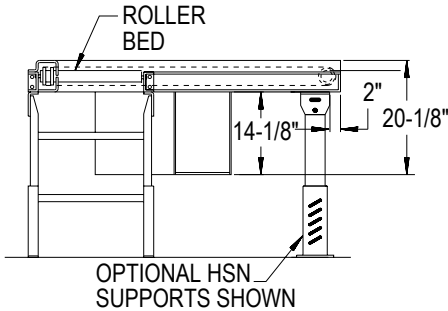

• STANDARD SPECIFICATIONS

BED—Roller bed with 2 ½ in. dia. x 11 ga. unplated rollers mounted in 4 in. x 4 ga. powder painted formed steel channel frame.

DRIVE—Mounted underneath, placed near center of conveyor.

DRIVE CHAIN—No. 50 circular roller chain.

CHAIN GUARD—Formed steel, upper and lower chain guard mounted to top and bottom of channel frame to totally enclose drive chains.

BEARINGS—Sealed, pre-lubricated ball bearings.

BUTT COUPLINGS—Standard for connecting to 25-CRR, 2 ½ in. dia. or 2 ¾ in. dia. gravity roller conveyor.

SPEED REDUCTION—Sealed worm gear C-Face speed reducer.
MOTOR—1 HP—208/230/460/575V—3 Ph. 60 Hz. Totally Enclosed C-Face.

CONVEYING SPEED—Constant 30 FPM.

CAPACITY—4000 lbs. total distributed live load at 30 FPM.

FLOOR SUPPORTS—Now supplied as optional equipment.

• OPTIONAL EQUIPMENT

FLOOR SUPPORTS—HSN Type floor supports are available with a wide range of adjustment. Specify top of belt or roller elevation. One support required at every bed joint and ends of conveyor. Holes in feet for lagging to floor. Knee braces recommended above HSN-3 support.

CONVEYING SPEED—Other constant and variable speeds. V-belt drive supplied on speeds under 12 FPM (1 HP). **Note:** Capacity affected with speed change.

TOP SIDE MOUNTED DRIVE—Motor reducer unit mounted to side of conveyor with drive chain through top of chain guard. Specify clearances. Minimum elevation top of rollers 6 in.

V-BELT DRIVE—V-belt supplied between motor and reducer.

O-RING DRIVE CHAIN—With sealed in lubricant (Recommended for applications that do not permit regular lubrication).

FRAMES—4 in. x 5.4 lb. structural channel.

GUARD RAILS—Fixed angle (2 in. high x ¼ in. steel) guard bolts to top of flange of channel opposite chain guard.

ROLLERS SET LOW—Use angle guard rail.

TREAD ROLLERS—2 ¾ in. dia. x 7 ga. steel, 1 ¼ in. hex spring-loaded shaft (26-CRRC).

MOTORS—Energy efficient, single phase, brakemotor, other characteristics. 1 HP maximum.

TANGENTS—Lengths available on 5 in. increments (5 in. roller centers) up to 45 in. OAL. Other roller centers and lengths available (jackshaft required), contact factory.

ELECTRICAL CONTROLS—Non-reversing or reversible magnetic starters and push-button stations. AC variable frequency drive.