

# 25-CRRCT

## Chain Driven Live Tapered Roller Curve Conveyor (Roll-to-Roll Type)

The Model 25-CRRCT is a heavy-duty, chain driven live roller curve conveyor. It is commonly used in conjunction with the 25-CRR conveyor to carry heavy unit loads such as pallets and drums.

- 16 Widths
- Reversible
- Chain Driven Rollers
- Adjustable HSN-Type Floor Supports Available



HYTROL CONVEYOR COMPANY, INC.

Conveying Surface Width	Between Rail Width	Overall Frame Width	Outside Radius "OR"	WEIGHTS (Lbs.)				TREAD ROLLER TAPER DIMENSIONS
				90°	60°	45°	30°	
15 3/4"	19"	22 1/4"	58"	604	553	502	412	2 1/2" to 3 1/2" 11 Ga.
17 3/4"	21"	24 1/4"	60"	626	572	519	421	
19 3/4"	23"	26 1/4"	62"	647	592	535	435	
21 3/4"	25"	28 1/4"	64"	668	611	551	446	
23 3/4"	27"	30 1/4"	66"	689	630	567	464	2 1/2" to 4" 11 Ga.
27 3/4"	31"	34 1/4"	70"	732	669	600	485	
29 3/4"	33"	36 1/4"	72"	753	688	616	499	
33 3/4"	37"	40 1/4"	76"	796	729	648	533	2 1/2" to 4 1/2" 11 Ga.
35 3/4"	39"	42 1/4"	78"	817	747	664	550	
39 3/4"	43"	46 1/4"	82"	859	777	697	579	2 1/2" to 5" 11 Ga.
43 3/4"	47"	50 1/4"	86"	902	825	729	608	
47 3/4"	51"	54 1/4"	90"	944	863	761	637	
51 3/4"	55"	58 1/4"	94"	986	921	793	666	
57 3/4"	61"	64 1/4"	100"	1070	979	857	724	
63 3/4"	67"	70 1/4"	106"	1133	1036	905	768	

NO. OF ROLLERS			
90°	60°	45°	30°
14 Tapered	11 Tapered 5 Straight	7 Tapered 5 Straight	4 Tapered 5 Straight

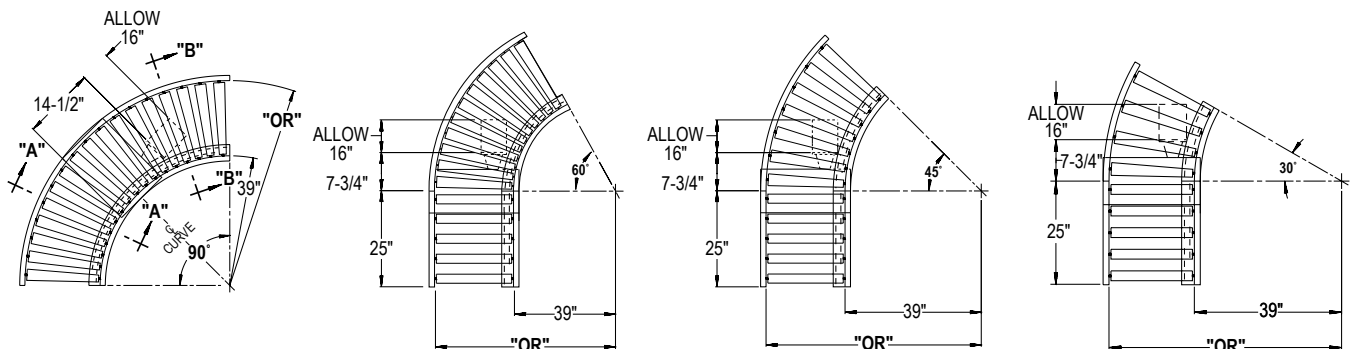
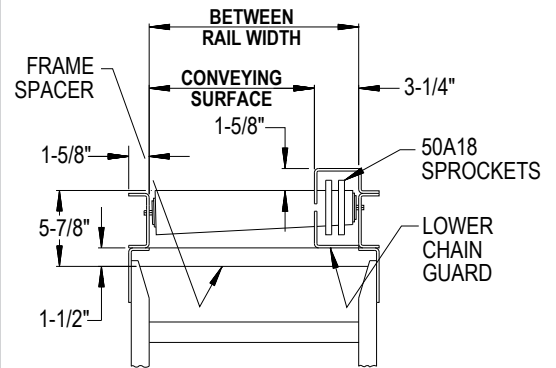
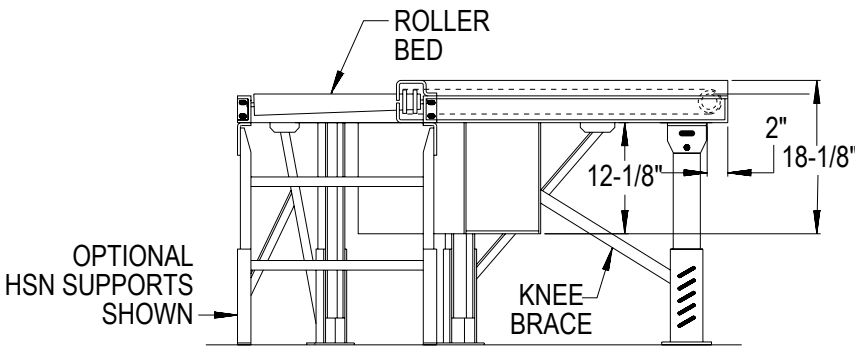
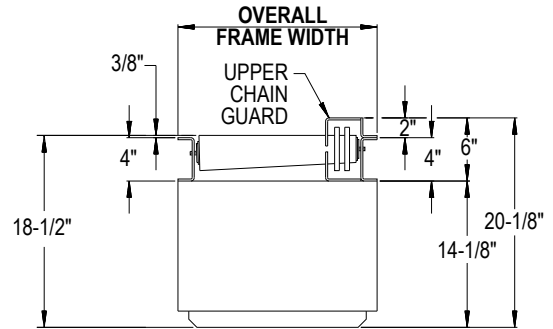

## • STANDARD SPECIFICATIONS

**BED**—Roller bed with unplated tread rollers mounted in 4 in. x 4 ga. powder painted formed steel frame. (See dimension chart for roller details.)

**CENTER DRIVE**—Mounted underneath bed section.

**DRIVE CHAIN**—No. 50 circular roller chain.

**CHAIN GUARD**—Formed steel, upper and lower chain guard mounted to top and bottom of channel frame to totally enclose drive chains.

**BEARINGS**—Sealed, pre-lubricated ball bearings.

**BUTT COUPLINGS**—Standard for connecting to 25-CRR, 2 1/2 in. dia. or 2 5/8 in. dia. gravity roller conveyor.

**SPEED REDUCTION**—Sealed worm gear C-Face speed reducer.

**MOTOR**—1 HP—208/230/460/575V—3 Ph. 60 Hz. Totally Enclosed C-Face.

**CONVEYING SPEED**—Constant 30 FPM.

**CAPACITY**—4000 lbs. total distributed live load at 30 FPM.

**FLOOR SUPPORTS**—Now supplied as optional equipment.

**TANGENTS**—25 in. long tangent on 30, 45 and 60 degree curves.

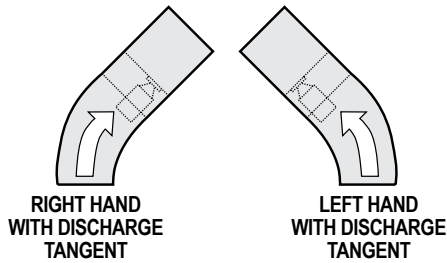

NOTE: SPECIFY RH OR LH CURVE

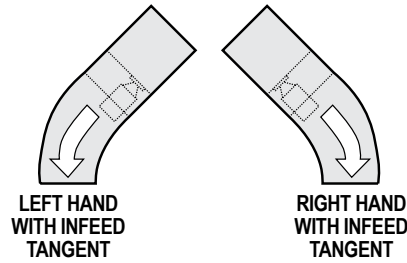

NOTE: SPECIFY RH OR LH CURVE

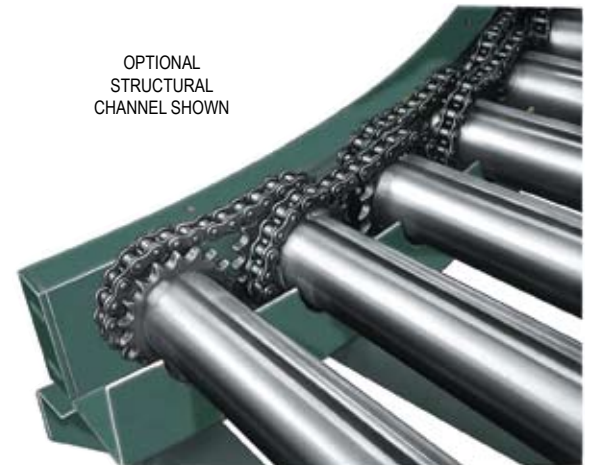

Chain Roll-To-Roll design provides positive drive of tapered tread rollers. Chain Guard removed to illustrate Roll-To-Roll Drive Chain.

WARNING: Do not operate conveyor with Chain Guard removed.

## • OPTIONAL EQUIPMENT

**FLOOR SUPPORTS**—HSN Type floor supports are available with a wide range of adjustment. Specify top of belt or roller elevation. One support required at every bed joint and ends of conveyor. Holes in feet for lagging to floor. Knee braces recommended above HSN-3 support.

**CONVEYING SPEED**—Other constant and variable speeds. V-belt drive supplied under 12 FPM (1 HP).  
**Note:** Capacity affected with speed change.

**TOP SIDE MOUNTED DRIVE**—Motor reducer unit mounted to side of conveyor with drive chain through top of chain guard. Specify clearances. Minimum elevation top of rollers 6 in.

**V-BELT DRIVE**—V-Belt supplied between motor and reducer.

**O-RING DRIVE CHAIN**—With sealed in lubricant (Recommended for applications that do not permit regular lubrication).

**FRAMES**—4 in. x 5.4 lb. structural channel.

**GUARD RAILS**—Fixed angle (2 in. high x 1/4 in. steel) guard bolts to top flange of channel opposite chain guard.

**MOTORS**—Energy efficient, single phase, brakemotor, other characteristics. 1 HP maximum.

**SLAVE DRIVEN**—Requires jackshaft.

**TANGENTS**—Lengths available on 5 in. increments (5 in. roller centers) up to 45 in. OAL. Other roller centers and lengths available (jackshaft required), contact factory.

**ELECTRICAL CONTROLS**—Non-reversing magnetic starters and push-button stations. AC variable frequency drive.