

Horizontal Wire Mesh Belt Conveyor

The Model TW with wire belt can carry hot or cold parts from ovens or freezers. Can be used in drying operations.

- 3 Belt Widths
- Wire Mesh Belt
- Adjustable MS-Type Floor Supports Available

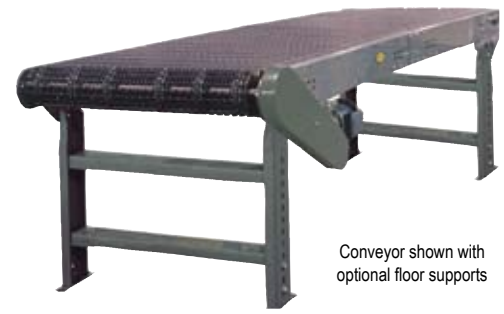

Conveyor shown with optional floor supports

SIZE TO ORDER Overall Length "A"	Bed Length "L"	Belt Width	12"	18"	24"
			16"	22"	28"
6'-1"	5'	WEIGHTS (Lbs.)	299	322	365
11'-1"	10'		368	415	465
16'-1"	15'		461	525	593
21'-1"	20'		530	608	693
26'-1"	25'		623	718	821
31'-1"	30'		692	801	921
41'-1"	40'		854	994	1149
51'-1"	50'		1023	1197	1391
61'-1"	60'		1185	1390	1609
71'-1"	70'		1355	1594	1862
81'-1"	80'		1517	1787	2090
91'-1"	90'		1697	1979	2319
101'-1"	100'	1841	2172	2547	

All weights in catalog are conveyor weights only. Accessories, crating, etc., are not included.

HP	BED WIDTHS—16" to 28"	
	TOTAL LOAD (Lbs.)	
	UP TO 50'	UP TO 100'
½	850	350
1	1950	1500

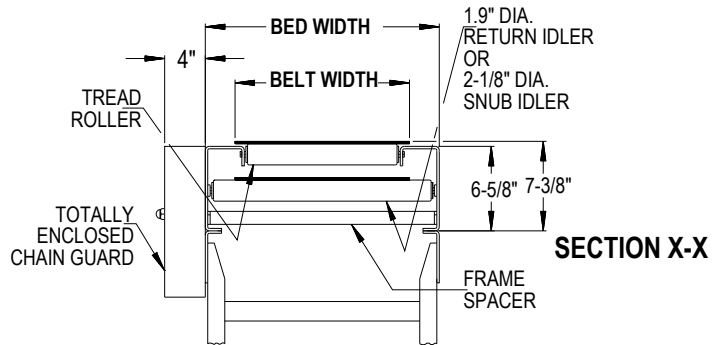
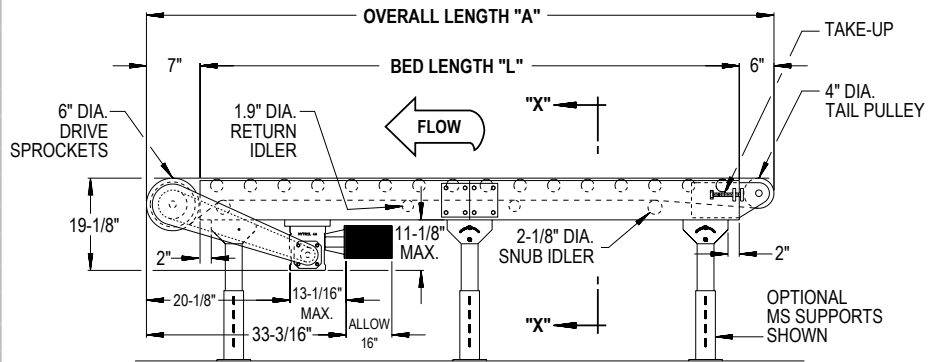

• STANDARD SPECIFICATIONS

BELT—½ in. x 1 in. flat galvanized wire mesh belt. Maximum product temperature 350°F.

BED—Roller bed with 1.9 in. dia. roller x 16 ga. galvanized tube spaced every 6 in. Mounted in 6 ½ in. x 12 ga. powder painted formed steel channel frame bolted together with splice plates.

END DRIVE—Located on discharge end of conveyor, chain guard on left hand side.

CROSS BRACING—Rods with turnbuckles are fastened to underside of bed to provide alignment of bed rollers to insure correct belt tracking. Required on every other section 30 ft. bed lengths and over.

DRIVE SPROCKETS—6 in. pitch dia. multiple cast iron sprockets with 1 ¾ in. dia. shaft 6 in. centers.

TAIL PULLEY—4 in. dia. with 1 in. dia. shaft at bearings. Sprocket at each end.

SNUB IDLER—Adjustable 2 ½ in. dia. pre-lubricated ball bearings.

• OPTIONAL EQUIPMENT

FLOOR SUPPORTS—MS Type floor supports are available with a wide range of adjustment. Specify top of belt or roller elevation. One support required at every bed joint and ends of conveyor. Holes in feet for lagging to floor. Knee braces recommended above MS-6 support.

BED—Slider bar in place of roller bed.

BELT—Other widths than standard, galvanized low carbon steel, bright high carbon steel or stainless steel. 1 in. or ½ in. x ½ in. mesh available. Maximum product temperature 750°F with high carbon steel belt.

BELT SPEED—Other constant and variable speeds. V-belt drive supplied on speeds under 15 FPM and with variable speeds. **Note:** Capacity affected with speed change.

RETURN IDLER—Adjustable 1.9 in. dia. pre-lubricated ball bearings.

TAKE-UP—Take-ups at tail pulley. Provides 4 in. of belt take-up.

BEARINGS—Sealed, pre-lubricated, self-aligning ball bearings on drive and tail shafts. Pre-lubricated ball bearings in tread rollers.

SPEED REDUCTION—Sealed worm gear C-Face speed reducer. No. 50 roller chain to drive sprocket.

MOTOR—½ HP—208/230/460/575V—3 Ph. 60 Hz. Totally Enclosed C-Face.

BELT SPEED—Constant 65 FPM.

CAPACITY—Maximum load per linear foot of conveyor 75 lbs. NOT TO EXCEED capacity in chart.

FLOOR SUPPORTS—Now supplied as optional equipment.

V-BELT DRIVE—V-belt supplied between motor and reducer.

O-RING DRIVE CHAIN—With sealed in lubricant (Recommended for applications that do not permit regular lubrication).

CEILING HANGARS—½ in. dia. x 8 ft. long unplated rods fully threaded. Other lengths and galvanized rods available.

MOTORS—Energy efficient, single phase, brakemotor, other characteristics. 1 HP maximum.

ELECTRICAL CONTROLS—Non-reversing magnetic starters and push-button stations. AC variable frequency drive.