

Belt

Live Roller Conveyors

Driven

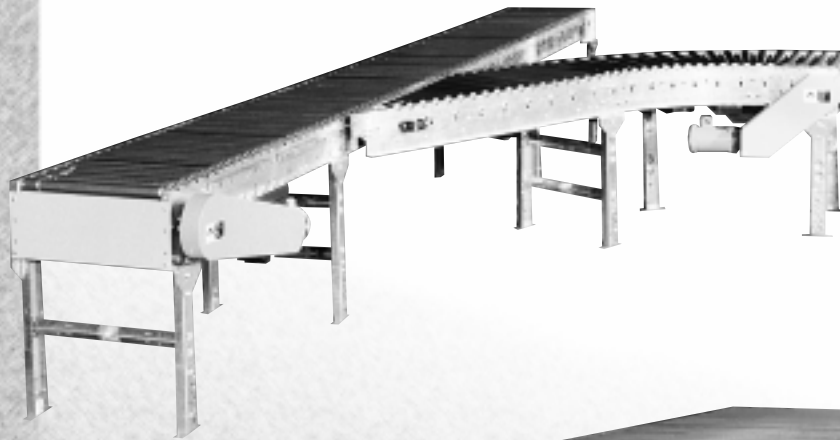

Belt Driven Live
Roller Conveyors

Light Duty

Transportation Type 196

Minimum Pressure Accumulation Type 198

Medium Duty

Transportation Type 200

Heavy Duty

Transportation Type 202

V-Belt Driven Live Roller Curve Conveyor 204

Straight Spur Conveyor 206

Curve Spur Conveyor 208

Omni Metalcraft Corp

Light Duty Belt Driven Live Roller Conveyor Transportation Type

1.9 in. dia. x 16 ga. Galvanized "Pop-Out" Tread

Model BDRE-T provides a versatile means of transporting products of varying sizes and shapes. The tread rollers are driven by a belt which is forced against the tread roller by a pressure roller.



Model BDRE-T

- Bolt-Together Construction
- 6 1/2 in. x 1 1/2 in. x 12 ga. Galvanized Frame
- Between Frame Widths 13 in. Through 39 in.
- Reversible (With Center Drive)

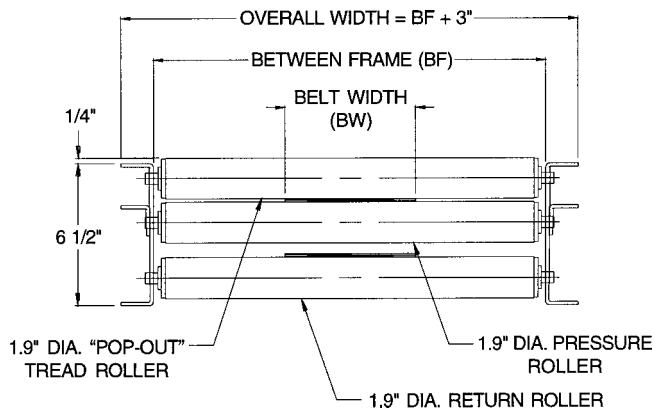

Intermediate Cross Section

OAL	CONVEYOR WEIGHT (LBS.)							
	BETWEEN FRAME (BF)*							
	14"	18"	22"	26"	32"	38"		
5' 10'	4 in. dia. drive, 4 in. dia. tail	230	262	295	330	380	8 in. dia. drive pulley, 4 in. dia. tail pulley	431
		357	410	462	518	598		680
		486	559	632	707	818		929
		614	707	800	895	1036		1177
		743	856	969	1084	1256		1427
		871	1004	1137	1271	1474		1675
35' 40'	4 in. dia. drive, 4 in. dia. tail	1000	1153	1307	1461	1693	8 in. dia. drive pulley, 4 in. dia. tail pulley	1925
		1128	1301	1474	1648	1911		2173
		1257	1450	1644	1838	2131		2423
		1384	1598	1812	2025	2349		2671
		1521	1754	1986	2219	2571		2920
		1649	1901	2154	2406	2789		3168
65' 70'	8 in. dia. drive, 4 in. dia. tail	1778	2051	2324	2596	3008	8 in. dia. drive pulley, 4 in. dia. tail pulley	3418
		1906	2199	2491	2783	3226		3666
		2035	2348	2661	2972	3446		3916
		2162	2496	2829	3160	3664		4164
		2292	2645	2998	3349	3884		4414
		2419	2793	3166	3537	4102		4661
95' 100'	8 in. dia. drive, 4 in. dia. tail	2549	2942	3336	3726	4321	8 in. dia. drive pulley, 4 in. dia. tail pulley	4911
		2676	3090	3503	3914	4539		5159

* Other widths are available as standard from 13" through 39".

NOTE: A short belt segment laced on both ends, commonly called a "dutchman", is provided with conveyors over 47 ft. OAL. This allows future belt stretch with standard end take-up. If a short segment is not desired, a center drive/take-up is required.

Standard Specifications:

Belt - 6 in. wide PVC-120 with clipper lacing. 12 in. wide for 32 in. between frame and larger.

Bed - Roller bed with 1.9 in. dia. x 16 ga. galvanized "pop-out" tread rollers spaced on 3 in. centers and 1.9 in. dia. x 16 ga. galvanized pressure rollers spaced on 6 in. centers. Mounted in 6 1/2 in. deep x 1 1/2 in. x 12 ga. galvanized steel channel frames. Standard 5 ft. and 10 ft. long bolt-together sections with bolt-on end couplers.

Floor Supports - Adjustable 34 1/2 in. to 39 in. top of roller with 4 in. drive or 33 1/2 in. to 39 in. for 8 in. drive. One support at every bed joint and at ends of conveyor.

Cross Bracing - Rods with turn buckles supplied on every other section for conveyors 30 ft. and longer. Allows frame to be squared to improve belt tracking.

Drive Pulley - 4 in. dia. with 1 3/16 in. dia. shaft or 8 in. dia. with 1 7/16 in. dia. shaft, crowned and fully lagged.

Tail Pulley - 4 in. dia. with 1 3/16 in. dia. shaft, crowned.

Snub Roller - 2 1/2 in. dia. galvanized with grease packed ball bearings (adjustable).

Return Rollers - 1.9 in. dia. galvanized with grease packed ball bearings.

Take-Up - Provides belt take-up at tail pulley to allow for future belt stretch.

Bearings - Sealed, pre-lubricated, self-aligning ball bearings on drive and tail pulleys.

Conveying Speed - Constant 60 FPM.

Speed Reduction - Sealed worm gear "C" face speed reducer with No. 50 chain to drive pulley.

Motor - 1/2 HP - 230/460 V - 3 Phase - 60 Hz. - totally enclosed, fan cooled.

Electrical Controls - Available as option.

Frame Capacity - Max. load per linear foot with legs on 10 ft. centers = 310 lbs. Not to exceed capacities in chart on next page.

4 in. End Drive

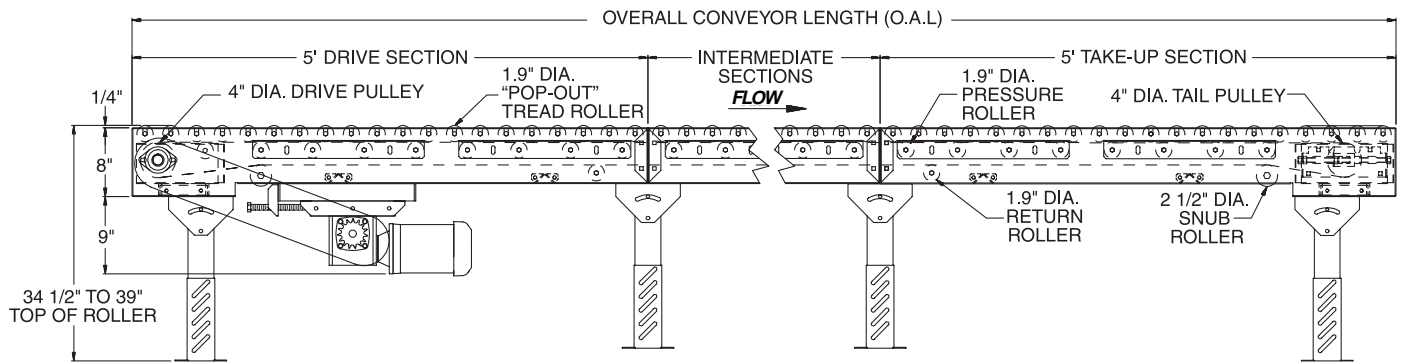

8 in. End Drive

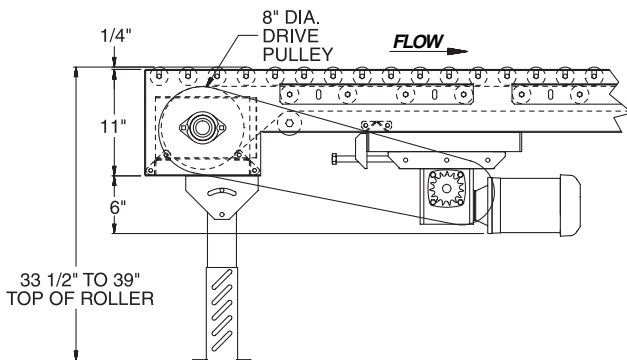

Standard Right-Hand Drive Location

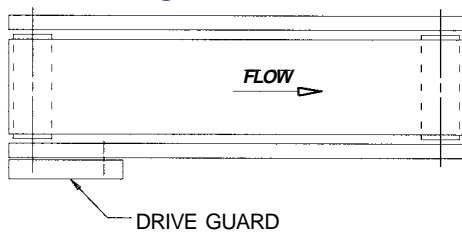

MAXIMUM UNIFORMLY DISTRIBUTED LIVE LOAD						
Belt Driven Live Roller Conveyor @ 60 FPM						
HP	13 - 18 in. Between Frame		19 - 26 in. Between Frame		27 - 39 in. Between Frame	
	5 - 50 ft.	55 - 100 ft.	5 - 50 ft.	55 - 100 ft.	5 - 50 ft.	55 - 100 ft.
1/2	650	--	270	--	--	--
3/4	1510	510	1130	--	430	--
1	2460	1460	2100	670	1400	--
1 1/2	3760*	3100	3400*	2000	2780	750*
2	5400*	4300*	5000*	3600*	4400*	2370*

* 8 in. dia. drive pulley in lieu of 4 in. dia. drive pulley

Transportation Type BDLR Model Number:

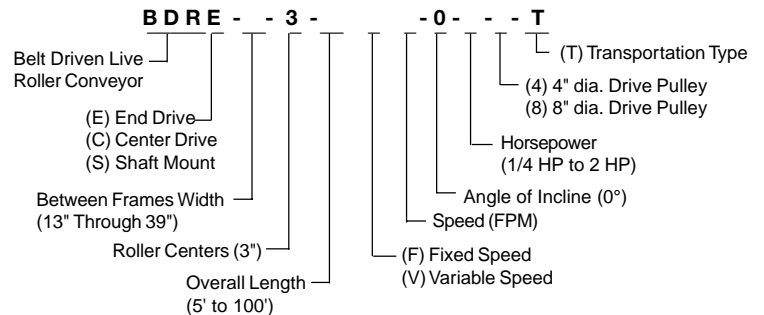

Optional Equipment:

Belt - 3-ply neoprene friction surface.

Conveying Speed - Constant and variable speeds available other than standard 60 FPM.

Center Drive - Provides additional belt take-up and is suitable for reversible applications.

Roller Centers - Tread rollers spaced on 4 in., 6 in., 8 in. or 9 in. centers. *CAUTION: With tread rollers on centers over 3 in. there is an increased likelihood of a person's hand, foot, clothing, etc. slipping between the rollers. OMNI MUST RECEIVE WRITTEN ACKNOWLEDGMENT that the end user is aware of the potential safety hazard and will safeguard accordingly.*

Fixed Angle Guard Rails - 1 1/2 in. x 2 in. or 1 1/2 in. x 6 in. formed 12 ga. galvanized angle. Other heights available. Channel types available. One or both sides. Spaced up to allow rollers to pop out.

Note: If product contacts guard rail, product flow may be affected.

Floor Supports - Heights available up to 84 in. top of leg.

Ceiling Hangers - 5/8 in. dia. x 10 ft. long threaded rod with mounting hardware. Other lengths available.

Tail Pulley - 6 in. dia. with 1 3/16 in. dia. shaft, crowned.

Other Drive Types - Shaft mount, side mount chain driven to allow lower top of belt.

Motors - Single phase, explosion proof, drip proof, DC motors, inverter duty, etc. Available through 2 HP.

Electrical Controls - Start-stop push-button station, reverse drum switch, one direction and reversible magnetic starters.

Tread Rollers - 1.9 in. dia. x .145 in. wall., 1.9 in. dia. x 13 ga.

Blade Stops - Pneumatically or manually operated blade that pops up between rollers in order to accumulate product.

Pusher Device - Used to automatically divert product. Ram head is pneumatically actuated to divert product at 90° onto another conveyor, chute, etc.

Transfer Device - Chain or V-Belt. An air operated lifting device that raises above the roller surface to transfer product off at 90°.

Zero-Pressure Accumulation - Allows product to accumulate without build-up of line pressure. Optional positive brakes for each zone. Sensor roller or photo-eye controlled logic.

Light Duty Belt Driven Live Roller Conveyor

Minimum Pressure Accumulation Type

1.9 in. dia. x 16 ga. Galvanized "Pop-Out" Tread

Model BDRE-M provides an inexpensive means of accumulating products with minimum back pressure. The tread rollers are driven by a belt which is forced against the tread roller by a pressure roller.

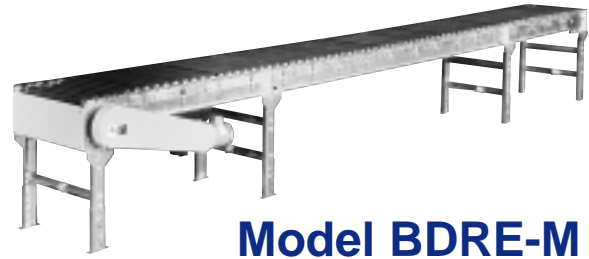

Model BDRE-M

- Bolt-Together Construction
- 6 1/2 in. x 1 1/2 in. x 12 ga. Galvanized Frame
- Between Frame Widths 13 in. Through 39 in.
- Reversible (With Center Drive)

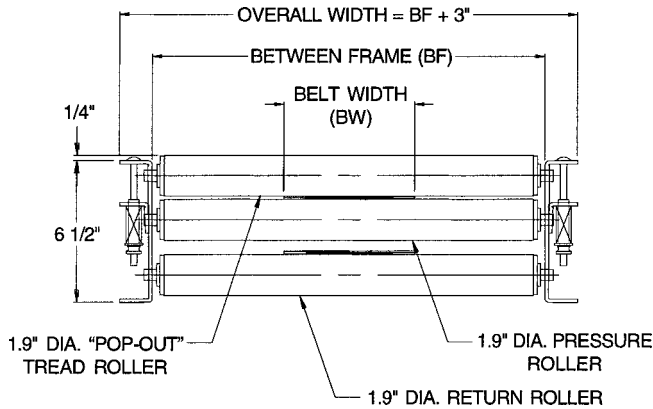

Intermediate Cross Section

OAL	CONVEYOR WEIGHT (LBS.)						
	BETWEEN FRAME (BF)*						
	14"	18"	22"	26"	32"	38"	
5'	231	263	297	331	382	432	4 in. dia. tail pulley
10'	359	411	465	519	600	681	
15'	489	562	635	709	821	931	4 in. dia. tail pulley
20'	617	710	804	898	986	1180	
25'	747	860	974	1088	1259	1430	4 in. dia. tail pulley
30'	875	1008	1142	1276	1478	1679	
35'	1005	1158	1313	1466	1698	1929	4 in. dia. tail pulley
40'	1133	1306	1481	1654	1917	2178	
45'	1263	1457	1651	1844	2137	2428	4 in. dia. tail pulley
50'	1391	1605	1819	2032	2356	2677	
55'	1528	1761	1994	2225	2578	2927	8 in. dia. drive pulley, 4 in. dia. tail pulley
60'	1656	1909	2162	2414	2796	3176	
65'	1786	2059	2333	2604	3017	3426	8 in. dia. drive pulley, 4 in. dia. tail pulley
70'	1914	2207	2501	2792	3235	3675	
75'	2044	2357	2671	2982	3455	3925	8 in. dia. drive pulley, 4 in. dia. tail pulley
80'	2172	2505	2840	3170	3674	4174	
85'	2302	2656	3010	3360	3894	4424	8 in. dia. drive pulley, 4 in. dia. tail pulley
90'	2430	2804	3178	3548	4113	4673	
95'	2560	2954	3348	3738	4333	4923	8 in. dia. drive pulley, 4 in. dia. tail pulley
100'	2688	3102	3517	3926	4552	5171	

* Other widths are available as standard from 13" through 39".

NOTE: A short belt segment laced on both ends, commonly called a "dutchman", is provided with conveyors over 47 ft. OAL. This allows future belt stretch with standard end take-up. If a short segment is not desired, a center drive/take-up is required.

Standard Specifications:

Belt - 6 in. wide PVC-120 with clipper lacing. 12 in. wide for 32 in. between frame and larger.

Bed - Roller bed with 1.9 in. dia. x 16 ga. galvanized "pop-out" tread rollers spaced on 3 in. centers and 1.9 in. dia. x 16 ga. galvanized pressure rollers spaced on 6 in. centers. Mounted in 6 1/2 in. deep x 1 1/2 in. x 12 ga. galvanized steel channel frames. Standard 5 ft. and 10 ft. long bolt-together sections with bolt-on end couplers.

Floor Supports - Adjustable 34 1/2 in. to 39 in. top of roller with 4 in. drive or 33 1/2 in. to 39 in. for 8 in. drive. One support at every bed joint and at ends of conveyor.

Cross Bracing - Rods with turn buckles supplied on every other section for conveyors 30 ft. and longer. Allows frame to be squared to improve belt tracking.

Drive Pulley - 4 in. dia. with 1 3/16 in. dia. shaft or 8 in. dia. with 1 7/16 in. dia. shaft, crowned and fully lagged.

Tail Pulley - 4 in. dia. with 1 3/16 in. dia. shaft, crowned.

Snub Roller - 2 1/2 in. dia. galvanized with grease packed ball bearings (adjustable).

Return Rollers - 1.9 in. dia. galvanized with grease packed ball bearings.

Take-Up - Provides belt take-up at tail pulley to allow for future belt stretch.

Bearings - Sealed, pre-lubricated, self-aligning ball bearings on drive and tail pulleys.

Conveying Speed - Constant 60 FPM.

Speed Reduction - Sealed worm gear "C" face speed reducer with No. 50 chain to drive pulley.

Motor - 1/2 HP - 230/460 V - 3 Phase - 60 Hz. - totally enclosed, fan cooled.

Electrical Controls - Available as option.

Frame Capacity - Max. load per linear foot with legs on 10 ft. centers = 310 lbs. Not to exceed capacities in chart on next page.

4 in. End Drive

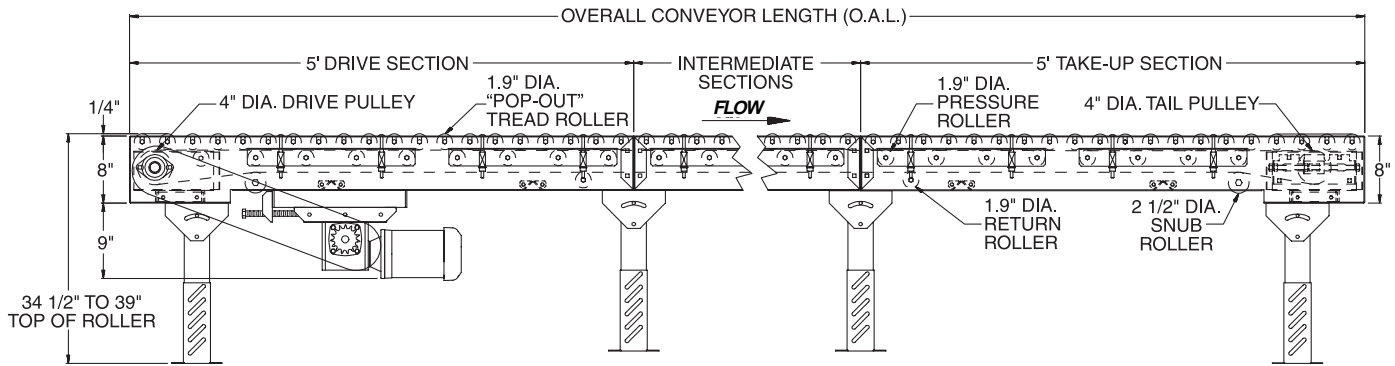

8 in. End Drive

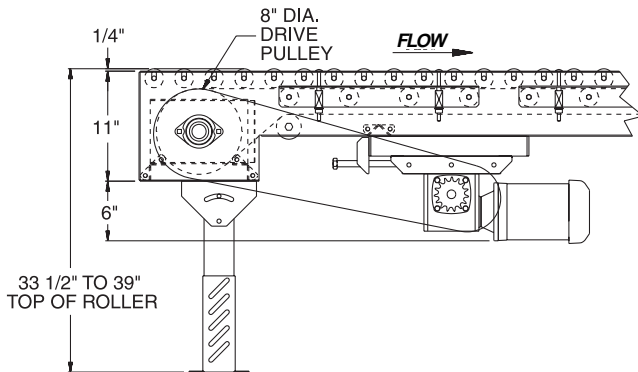

MAXIMUM UNIFORMLY DISTRIBUTED LIVE LOAD						
Belt Driven Live Roller Conveyor @ 60 FPM						
HP	13 - 18 in. Between Frame		19 - 26 in. Between Frame		27 - 39 in. Between Frame	
	5 - 50 ft.	55 - 100 ft.	5 - 50 ft.	55 - 100 ft.	5 - 50 ft.	55 - 100 ft.
1/2	650	--	270	--	--	--
3/4	1510	510	1130	--	430	--
1	2460	1460	2100	670	1400	--
1 1/2	3760*	3100	3400*	2000	2780	750*
2	5400*	4300*	5000*	3600*	4400*	2370*

* 8 in. dia. drive pulley in lieu of 4 in. dia. drive pulley

Standard Right-Hand Drive Location

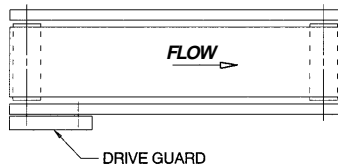

Minimum Pressure Type BDLR Model Number:

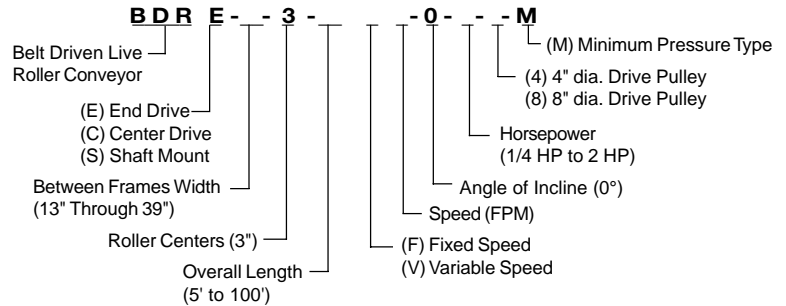

Optional Equipment:

Belt - 3-ply neoprene friction surface.

Conveying Speed - Constant and variable speeds available other than standard 60 FPM.

Center Drive - Provides additional belt take-up and is suitable for reversible applications.

Roller Centers - Tread rollers spaced on 4 in., 6 in., 8 in. or 9 in. centers. *CAUTION: With tread rollers on centers over 3 in. there is an increased likelihood of a person's hand, foot, clothing, etc. slipping between the rollers. OMNI MUST RECEIVE WRITTEN ACKNOWLEDGMENT that the end user is aware of the potential safety hazard and will safeguard accordingly.*

Fixed Angle Guard Rails - 1 1/2 in. x 2 in. or 1 1/2 in. x 6 in. formed 12 ga. galvanized angle. Other heights available. Channel types available. One or both sides. Spaced up to allow rollers to pop out.

Note: If product contacts guard rail, product flow may be affected.

Floor Supports - Heights available up to 84 in. top of leg.

Ceiling Hangers - 5/8 in. dia. x 10 ft. long threaded rod with mounting hardware. Other lengths available.

Tail Pulley - 6 in. dia. with 1 3/16 in. dia. shaft, crowned.

Other Drive Types - Shaft mount, side mount chain driven to allow lower top of belt.

Motors - Single phase, explosion proof, drip proof, DC motors, inverter duty, etc. Available through 2 HP.

Electrical Controls - Start-stop push-button station, reverse drum switch, one direction and reversible magnetic starters.

Tread Rollers - 1.9 in. dia. x .145 in. wall., 1.9 in. dia. x 13 ga.

Blade Stops - Pneumatically or manually operated blade that pops up between rollers in order to accumulate product.

Pusher Device - Used to automatically divert product. Ram head is pneumatically actuated to divert product at 90° onto another conveyor, chute, etc.

Transfer Device - Chain or V-Belt. An air operated lifting device that raises above the roller surface to transfer product off at 90°.

Zero-Pressure Accumulation - Allows product to accumulate without build-up of line pressure. Optional positive brakes for each zone. Sensor roller or photo-eye controlled logic.

Medium Duty Belt Driven Live Roller Conveyor Transportation Type

1.9 in. dia. x 16 ga. Galvanized or 1.9 in. dia. x .145 in. Wall Unplated "Pop-Out" Tread Rollers

Model MDBDLR is a welded version of Model BDRE-T on page 196. This allows greater frame capacity and wider between frame dimensions. It is an economical choice for products too large for the bolt-together version.

- Welded Construction
- 6 1/2 in. x 1 1/2 in. x 10 ga. Frame
- Between Frame Widths 13 in. Through 50 in.
- Reversible (With Center Drive)
- 1.9 in. dia. x 16 ga. Galvanized Tread Rollers For 13 in. - 39 in. Between Frames
- 1.9 in. dia. x .145 in. Wall Unplated Tread Rollers For 40 in. - 50 in. Between Frames

Model MDBDLR

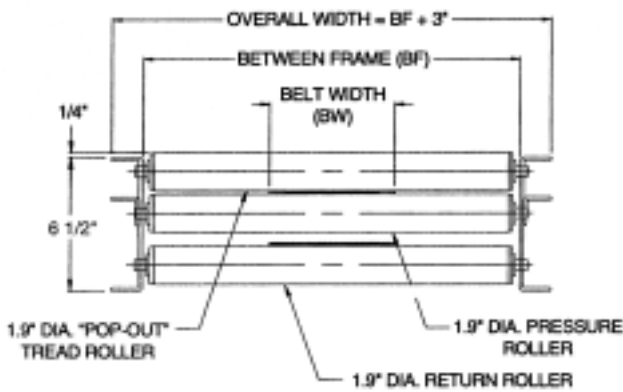

Intermediate Cross Section

OAL	CONVEYOR WEIGHT (LBS.)							
	BETWEEN FRAME (BF)*							
	18"	22"	26"	32"	38"	44"	50"	
5'	663	682	701	730	944	988	1031	
10'	968	1007	1045	1103	1482	1569	1655	
15'	1273	1331	1389	1476	2020	2150	2280	
20'	1579	1656	1733	1849	2557	2731	2904	
25'	1884	1981	2077	2222	3095	3312	3529	
30'	2190	2306	2422	2595	3633	3893	4153	
35'	2495	2630	2677	2968	4171	4474	4778	
40'	2801	2955	3110	3341	4708	5055	5402	
45'	3106	3280	3454	3714	5246	5636	6026	
50'	3412	3605	3798	4087	5784	6217	6651	
55'	3751	3964	4176	4495	6321	6798	7275	
60'	4057	4288	4520	4868	6859	7379	7900	
65'	4362	4618	4864	5241	7397	7961	8524	
70'	4668	4938	5208	5614	7935	8542	9149	
75'	4978	5263	5552	5987	8472	9123	9773	
80'	5279	5588	5896	6360	9010	9704	10398	
85'	5584	5912	6240	6733	9548	10285	11022	
90'	5890	6237	6585	7106	10086	10866	11646	
95'	6195	6562	6929	7479	10623	11447	12271	
100'	6500	6887	7273	7852	11161	12028	12895	

* Other widths are available as standard from 13" through 50".

Standard Specifications:

Belt - 6 in. wide PVC-120 with hidden clipper lacing. 12 in. wide for 32 in. between frame and larger.

Bed - Roller bed with 1.9 in. dia. x 16 ga. galvanized or 1.9 in. dia. x .145 in. wall unplated "pop-out" tread rollers spaced on 3 in. centers and 1.9 in. dia. x 16 ga. galvanized pressure rollers spaced on 6 in. centers. Mounted in 6 1/2 in. deep x 1 1/2 in. x 10 ga. painted steel channel frames. Standard 5 ft. and 10 ft. long welded sections with welded-in end couplers.

Floor Supports - 3 in. structural channel legs with 4 in. adjustment. Available up to 89 in. top of roller. One support at every bed joint and at ends of conveyor.

Drive Pulley - 4 in. dia. with 1 3/16 in. dia. shaft, 8 in. dia. with 1 7/16 in. dia. shaft or 1 11/16 in. dia. shaft, crowned and fully lagged.

Tail Pulley - 4 in. dia. with 1 3/16 in. dia. shaft, 6 in. dia. with 1 7/16 in. dia. shaft, crowned.

Snub Roller - 2 1/2 in. dia. galvanized with grease packed ball bearings (adjustable).

Return Roller - 1.9 in. dia. galvanized with grease packed ball bearings.

Take-Up - Provides belt take-up at tail pulley to allow for future belt stretch.

Bearings - Sealed, pre-lubricated, self-aligning ball bearings on drive and tail pulleys.

Conveying Speed - Constant 60 FPM.

Speed Reduction - Sealed worm gear base mount speed reducer with No. 50 chain to drive shaft.

Motor - 1/2 HP - 230/460 V - 3 Phase - 60 Hz. - totally enclosed, fan cooled.

Electrical Controls - Available as option.

Frame Capacity - Max. load per linear foot with legs on 10 ft. centers = 360 lbs. Not to exceed capacities in chart on next page.

4 in. End Drive

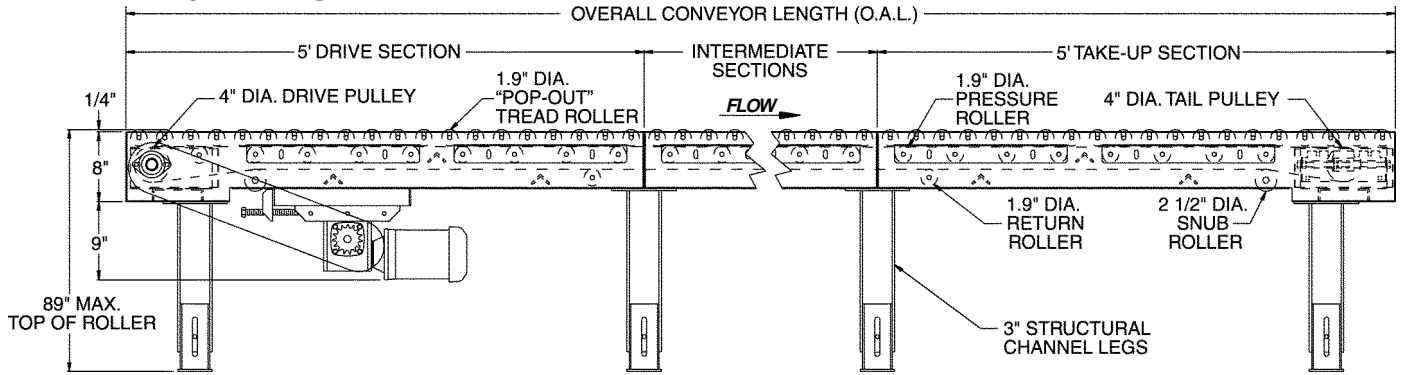

8 in. End Drive

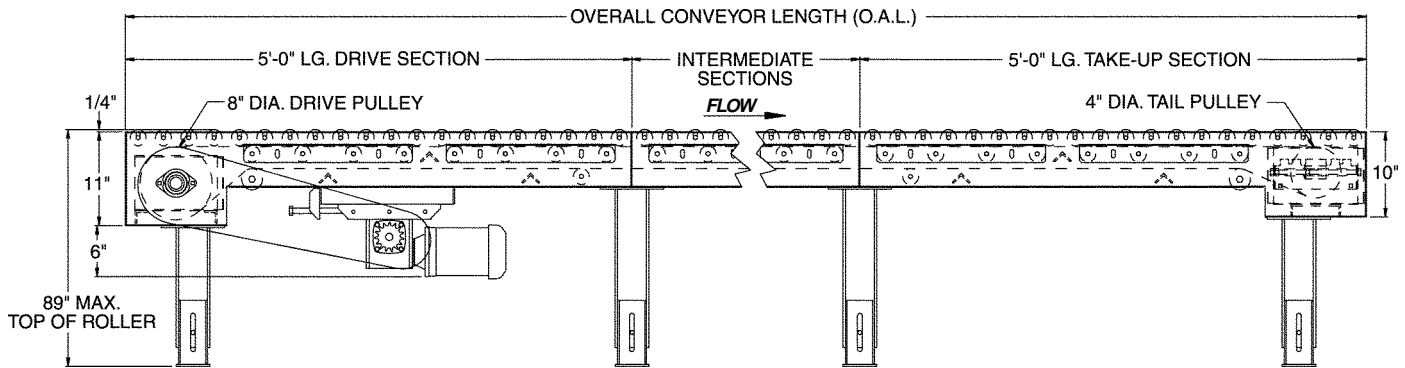

Standard Right-Hand Drive Location

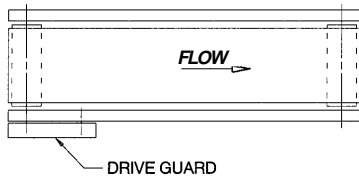

Optional Equipment:

Belt - 3-ply neoprene friction surface.

Conveying Speed - Constant and variable speeds available other than standard 60 FPM.

Center Drive - Provides additional belt take-up and is suitable for reversible applications.

Roller Centers - Tread rollers spaced on 4 in., 6 in., 8 in. or 9 in. centers. **CAUTION:** With tread rollers on centers over 3 in. there is an increased likelihood of a person's hand, foot, clothing, etc. slipping between the rollers. **OMNI MUST RECEIVE WRITTEN ACKNOWLEDGMENT** that the end user is aware of the potential safety hazard and will safeguard accordingly.

Fixed Angle Guard Rails - 1 1/2 in. x 2 in. or 1 1/2 in. x 6 in. formed 10 ga. Other heights available. Channel types available. One or both sides. Spaced up to allow rollers to pop out. **Note: If product contacts guard rail, product flow may be affected.**

Floor Supports - Larger structural channel legs available.

Ceiling Hangers - 1/4 in. formed angle mounted to underside of conveyor. Hanging hardware not included.

Tread Rollers - 1.9 in. dia. x 13 ga. rollers. 2 1/2 in. dia. x 11 ga. is also available but requires 7 in. high frame.

Other Drive Types - Shaft mount, side mount chain driven to allow lower top of belt.

Motors - Single phase, explosion proof, drip proof, DC motors, inverter duty, etc. Available through 2 HP.

Electrical Controls - Start/stop push-button station, reverse drum switch, one direction and reversible magnetic starters.

Blade Stops - Pneumatically or manually operated blade that pops up between rollers in order to accumulate product.

Pusher Device - Used to automatically divert product. Ram head is pneumatically actuated to divert product at 90° onto another conveyor, chute, etc.

Transfer Device - Chain or V-Belt. An air operated lifting device that raises above the roller surface to transfer product off at 90°.

Minimum Pressure Accumulation - Provides an inexpensive means of accumulating products with minimum back pressure.

Zero-Pressure Accumulation - Allows product to accumulate without build-up of line pressure. Optional positive brakes for each zone. Sensor roller or photo-eye controlled logic.

Heavy Duty Belt Driven Live Roller Conveyor

Transportation Type

2 1/2 in. dia. x 11 ga. "Pop-Out" Tread Rollers

Model HDBD is ideal for applications conveying heavy palletized or other similar product that may be side loaded and unloaded from a relatively low elevation (12 in. minimum). Zero-Pressure Accumulation is also an option.



Model HDBD
(Internal mount drive shown)

- **Welded Construction**
- **11 3/4 in. x 1 1/2 in. x 7 ga. Frame**
- **Between Frame Widths Up To 85 in.**
- **Reversible (With Center Drive)**

OAL	CONVEYOR WEIGHT (LBS.)									
	BETWEEN FRAME (BF)*									
	39"	45"	50"	55"	60"	65"	70"	75"	80"	85"
5'	1034	1089	1160	1206	1278	1324	1370	1441	1487	1533
10'	1662	1772	1911	2003	2142	2234	2326	2465	2557	2649
15'	2290	2456	2662	2800	3006	3144	3282	3488	3627	3765
20'	2918	3139	3412	3597	3870	4054	4239	4512	4696	4881
25'	3546	3823	4163	4393	4734	4964	5195	5535	5766	5996
30'	4174	4506	4913	5190	5598	5874	6151	6559	6835	7112
35'	4802	5189	5664	5987	6462	6785	7107	7582	7905	8228
40'	5430	5873	6415	6784	7326	7695	8064	8606	8975	9344
45'	6058	6556	7165	7581	8190	8605	9020	9629	10044	10459
50'	6686	7240	7916	8377	9054	9515	9976	10653	11114	11575

* Other widths are available as standard from 39" through 85".

Standard Specifications:

Belt - PVC-120 with hidden clipper lacing BF dependent.

Bed - Roller bed with 2 1/2 in. dia. x 11 ga. "pop-out" tread rollers spaced on 3 in. centers and 1.9 in. dia. x 16 ga. galvanized pressure rollers spaced on 6 in. centers. Mounted in 11 3/4 in. deep x 1 1/2 in. x 7 ga. painted steel channel frames. Standard 5 ft. and 10 ft. long welded sections with welded-in end couplers.

Drive Pulley - 8 in. dia. with 1 7/16 in. dia. shaft, crowned and fully lagged.

Tail Pulley - 4 in. dia. with 1 3/16 in. dia. shaft, crowned.

Snub Roller - 2 1/2 in. dia. with grease packed ball bearings (adjustable).

Return Rollers - 1.9 in. dia. galvanized with grease packed ball bearings.

Floor Supports - 4 in. structural channel legs with 4 in. adjustment. Available up to 89 in. top of roller. One support at every bed joint and at ends of conveyor.

Take-Up - Provides belt take-up at tail pulley to allow for future belt stretch.

Bearings - Sealed, pre-lubricated, self-aligning ball bearings on drive and tail pulleys.

Conveying Speed - Constant 30 FPM.

Motor - 1 HP - 230/460 V - 3 Phase - 60 Hz. - totally enclosed, fan cooled.

Electrical Controls - Available as option.

Frame Capacity - Max. load per linear foot with legs on 10 ft. centers = 1280 lbs. Not to exceed capacities in chart on next page.

Internal Mount Drive

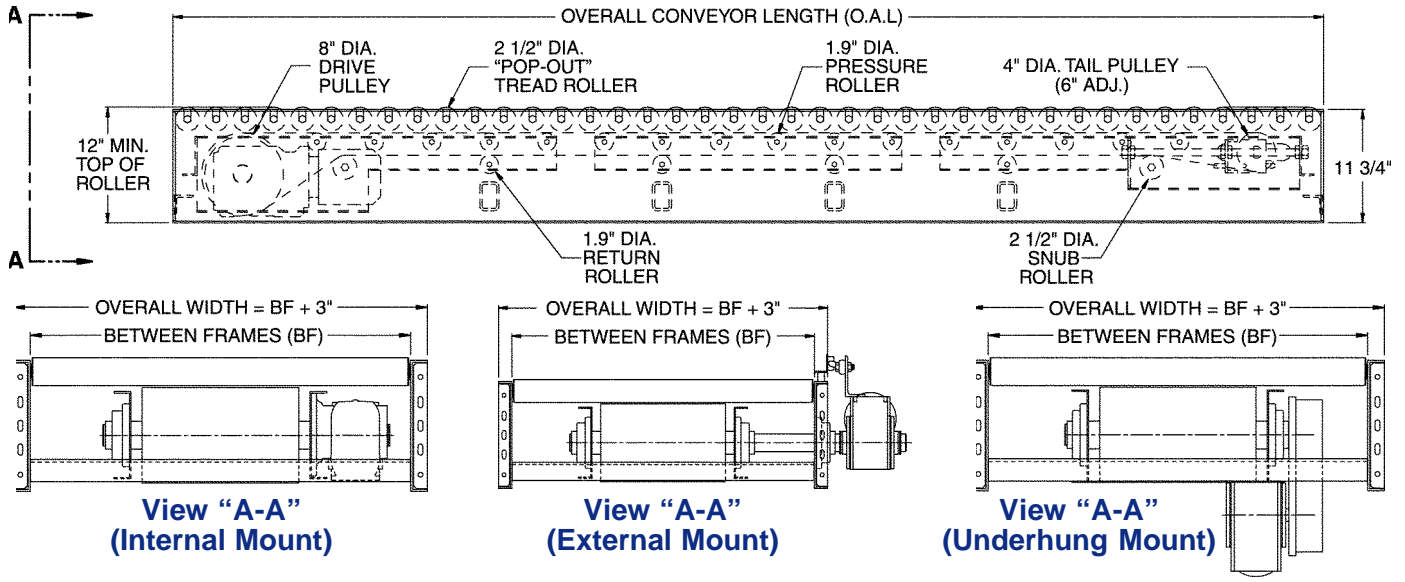

MAXIMUM UNIFORMLY DISTRIBUTED LIVE LOAD												
Belt Driven Live Roller Conveyor @ 30 FPM												
HP	39 - 45 in. Between Frame			46 - 55 in. Between Frame			56 - 70 in. Between Frame			71 - 85 in. Between Frame		
	5 - 15 ft.	20 - 30 ft.	35 - 50 ft.	5 - 15 ft.	20 - 30 ft.	35 - 50 ft.	5 - 15 ft.	20 - 30 ft.	35 - 50 ft.	5 - 15 ft.	20 - 30 ft.	35 - 50 ft.
3/4	3350	2150	600	3000	1500	--	2650	850	--	2350	--	--
1	5250	4050	2500	4900	3400	1400	4550	2750	300	4250	2050	--
1 1/2*	8500	7220	5600	8150	6650	4650	7850	6000	3550	7500	5350	2450
2*	11600	10350	8650	11400	9900	7900	11100	9250	6800	10750	8550	5700

Belt Driven Live Roller Conveyor @ 60 FPM												
HP	39 - 45 in. Between Frame			46 - 55 in. Between Frame			56 - 70 in. Between Frame			71 - 85 in. Between Frame		
	5 - 15 ft.	20 - 30 ft.	35 - 50 ft.	5 - 15 ft.	20 - 30 ft.	35 - 50 ft.	5 - 15 ft.	20 - 30 ft.	35 - 50 ft.	5 - 15 ft.	20 - 30 ft.	35 - 50 ft.
3/4	1150	--	--	900	--	--	600	--	--	--	--	--
1	2100	800	--	1850	350	--	1550	--	--	1200	--	--
1 1/2	3450	2150	450	3250	1700	--	2900	1050	--	2550	400	--
2*	5100	3800	2100	4850	3350	1350	4550	2700	--	4200	2000	--

* External or underhung mount drive required.

Optional Equipment:

Belt - 3-ply neoprene friction surface.

Conveying Speed - Constant and variable speeds available other than standard 30 FPM.

Center Drive - Provides additional belt take-up and is suitable for reversible applications.

Roller Centers - Tread rollers spaced on 4 in., 6 in., 8 in. and 9 in. available. *CAUTION: With tread rollers on centers over 3 in. there is an increased likelihood of a person's hand, foot, clothing, etc. slipping between the rollers. OMNI MUST RECEIVE WRITTEN ACKNOWLEDGMENT that the end user is aware of the potential safety hazard and will safeguard accordingly.*

Frames - MC 12 x 10.6# Junior Channel.

Fixed Angle Guard Rails - 1 1/2 in. x 2 in. or 1 1/2 in. x 6 in. formed 10 ga. Other heights available. Channel types available. One or both sides. Spaced up to allow rollers to pop out. **Note: If product contacts guard rail, product flow may be affected.**

Other Drive Types - Side mount chain driven to allow lower top of belt.

Motors - Single phase, explosion proof, drip proof, DC motors, inverter duty, etc. Available through 5 HP.

Electrical Controls - Start/stop push-button station, reverse drum switch, one direction and reversible magnetic starters.

Ceiling Hangers - 1/4 in. formed angle mounted to underside of conveyor. Hanging hardware not included.

Floor Supports - Larger structural channel legs available.

Blade Stops - Pneumatically or manually operated blade that pops up between rollers in order to accumulate product.

Tread Rollers - 2 9/16 in. OD x .180 in. wall unplated rollers, 11/16 in. hex spring retained axle or 3 1/2 in. OD x .300 in. wall unplated rollers, 1 1/16 in. hex spring retained axle.

Chain Transfer Device - An air operated lifting device that raises above the roller surface to transfer product off at 90°.

Turntable - Manual, hydraulic or gear motor operated turntable allows short conveyor mounts to rotate. Conveyor mounts to table surface.

Pivoting Device - Device used to pivot a short section conveyor about a fixed point while maintaining correct product orientation.

Iron Cross - Mechanism used to lift product above roller surface and rotate in 90° increments to change product orientation.

Transfer Car - Portable conveyors used to pick up and deliver product between parallel conveyor lines while maintaining correct product orientation.

Minimum Pressure Accumulation - Provides an inexpensive means of accumulating products with minimum back pressure.

Zero-Pressure Accumulation - Allows product to accumulate without build-up of line pressure. Optional positive brakes for each zone. Sensor roller or photoeye controlled logic.

V-Belt Driven Live Roller Curve Conveyor

11/16 in. dia. to 2 1/2 in. dia. x 14 ga. Zinc-Plated Tapered Rollers on Curve
1.9 in. dia. x 16 ga. Galvanized Straight Rollers on Tangents

The V-Belt Driven Live Roller Curve Conveyor is a live roller curve used to make 30°, 45°, 60° or 90° turns.



- 30°, 45°, 60° and 90° Curves
- 10 in. x 1 1/2 in. x 10 ga. Galvanized Frame on Tangents, 8 in. x 1 1/2 in. x 10 ga. Galvanized Frame on Curve
- Between Frame Widths 13 in. Through 39 in.
- Self Powered or Slave Driven
- Tapered Rollers on Curve, Straight Rollers on Tangents
- Transportation Conveyor Only
- Bolt-Together Construction

ROLLER CENTERS PER CURVE	
BETWEEN FRAME WIDTH	ROLLER CENTERS @ CENTERLINE
13"	2.781"
14"	2.814"
15"	2.847"
16"	2.880"
17"	2.913"
18"	2.945"
19"	2.978"
20"	3.011"
21"	3.043"
22"	3.076"
23"	3.109"
24"	3.142"
25"	3.174"
26"	3.207"
27"	3.240"
28"	3.272"
29"	3.305"
30"	3.338"
31"	3.371"
32"	3.403"
33"	3.436"
34"	3.469"
35"	3.502"
36"	3.534"
37"	3.567"
38"	3.600"
39"	3.632"

QUANTITY OF ROLLERS PER CURVE

- 30° Curve
 - 8 Tapered Rollers
 - 16 Straight Rollers
- 45° Curve
 - 12 Tapered Rollers
 - 16 Straight Rollers
- 60° Curve
 - 16 Tapered Rollers
 - 8 Straight Rollers
- 90° Curve
 - 24 Tapered Rollers
 - 8 Straight Rollers

Standard Specifications:

Belt - Endless "B" section V-belt.

Frame - 10 in. deep x 1 1/2 in. x 10 ga. galvanized steel channel frames with bolt on end couplers on tangents. 8 in. deep x 1 1/2 in. x 10 ga. galvanized steel channel frames on curve.

Outside rail of curve has "triple-punched" hex holes to allow skewing of rollers which affects product tracking.

Curve Roller - 2 1/2 in. dia. tapered to 1 11/16 in. dia. x 14 ga. zinc-plated rollers on 3 in. nom. centers. Grease-packed ball bearings. **Curve rollers do not represent true taper.**

Tangent Roller - 1.9 in. dia. x 16 ga. galvanized rollers on 3 in. centers. Grease-packed ball bearings.

Floor Supports - Adjustable 32 1/2 in. to 36 1/2 in. from floor to top of rollers. One support at ends of conveyor and one single leg support at center of curve.

Driving Sheave - 5 3/4 in. dia. V-belt sheave with 1 in. bore.

Pressure Sheave - 3 in. dia. V-belt sheave with 1/2 in. bore.

Idler Sheave - 3 in. dia. V-belt sheave with 1/2 in. bore or 3 in. dia. flat belt sheave with 1/2 in. bore.

Take-Up - Screw take-up with 3 in. dia. V-belt sheave with 1/2 in. bore. Provides take-up to allow for future belt tension.

Bearings - Sealed, pre-lubricated, self-aligning ball bearings.

Conveying Speed - Constant 60 FPM.

Speed Reduction - Sealed worm gear "C" face speed reducer with No. 50 chain to driving sheave.

Motor - 1/2 HP - 230/460 V - 3 Phase - 60 Hz. - totally enclosed, fan cooled.

Electrical Controls - Available as option.

Capacity - 500 lbs. total live load.

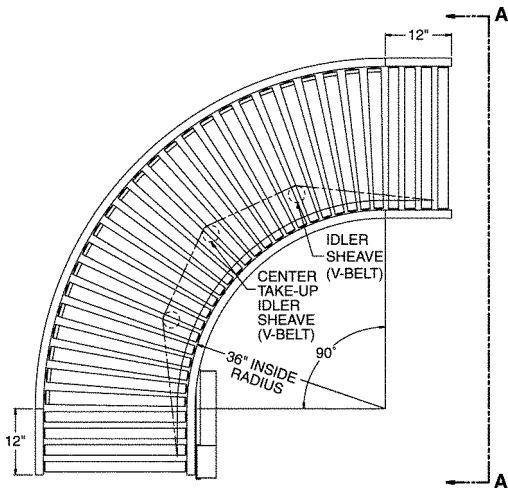

90° CURVE

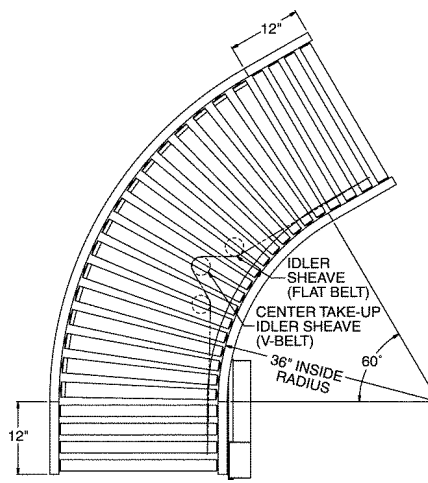

60° CURVE

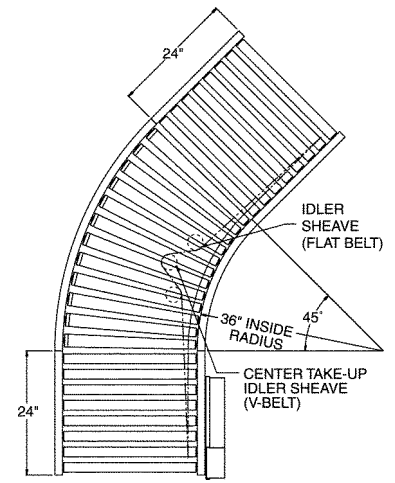

45° CURVE

**Standard Right Hand Drive
Location Shown on All Curves.**

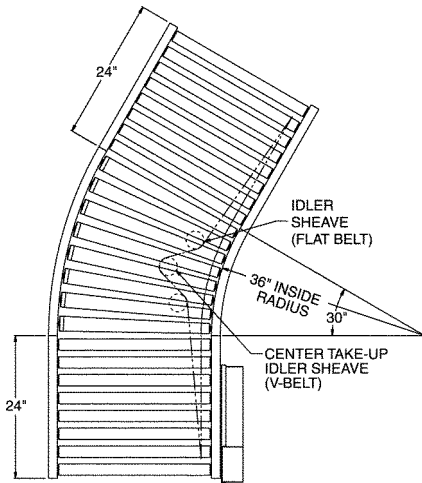

30° CURVE

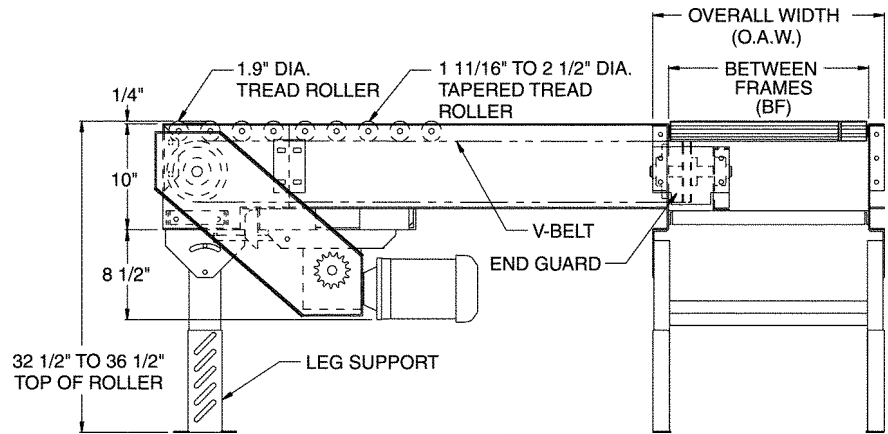

VIEW "A-A"

**Belt Driven Live
Roller Conveyors**

Optional Equipment:

Conveying Speed - Constant and variable speeds available other than standard 60 FPM.

Fixed Angle Guard Rails - 1 1/2 in. x 2 in. formed 12 ga. galvanized angle. Other heights available. Channel types available. One or both sides. **Note: If product contacts guard rails, product flow may be affected.**

Floor Supports - Heights available up to 84 in. top of leg.

Ceiling Hangers - 5/8 in. x 10 ft. long threaded rod with mounting hardware. Other lengths available.

Slave Driven - Curve to come less complete drive package and to be slaved to any belt driven live roller conveyor (V-belt or flat belt).

Other Tangent Lengths - Tangent lengths 12 in. through 48 in. available.

True Tapered Roller Curve - True tapered roller curve available. Will require special radius or special rollers.

Other Drive Types - Shaft mount to allow lower top of belt. Left hand drive.

Motors - Single phase, explosion proof, drip proof, DC motors, inverter duty, etc. Available through 2 HP.

Electrical Controls - Start/stop push-button station, reverse drum switch, one direction and reversible magnetic starters.

V-Belt Driven Live Roller Straight Spur Conveyor

1.9 in. dia. x 16 ga. Galvanized Straight Rollers

The V-Belt Driven Live Roller Straight Spur Conveyor is a live roller spur used where product lines converge or diverge.



- Bolt-Together Construction
- 30° and 45° Spurs
- 10 in. x 1 1/2 in. x 10 ga. Galvanized Frame on Head Section, 8 in. x 1 1/2 in. x 10 ga. Galvanized Frame on Spur
- Between Frame Widths 13 in. Through 39 in.
- Self Powered or Slave Driven
- Transportation Conveyor Only

Belt Driven Live Roller Conveyors

V-BELT DRIVEN LIVE ROLLER STRAIGHT SPUR CONVEYOR								
BETWEEN FRAME WIDTH	30° STRAIGHT SPUR			45° STRAIGHT SPUR				
	"A" (IN.)	"B" (IN.)	"C" (IN.)	"A" (IN.)	"B" (IN.)	"C" (IN.)		
13"	33 13/16	60	36	31 1/8	48	33		
14"	40 3/4		33					
15"			30					
16"	47 11/16	72	39	35 3/8	60	30		
17"			36					
18"			39 9/16	39		43 13/16	39	
19"			56 1/2					33
20"								30
21"	61 9/16	84	30	48 1/16	72	36		
22"			39					
23"			36	52 5/16		33	33	
24"			39					
25"			70 3/16	96		30	60 7/8	36
26"						33		
27"						30		
28"	75 3/8	99	39	56 9/16	72	39		
29"			36					
30"			33	60 7/8		36		
31"			30				65 1/16	33
32"			84 1/16	96		39		
33"	36							
34"	87 1/2	99	33	65 1/16	72	36		
35"			30					
36"			33					
37"	87 1/2	99	30	65 1/16	72	33		
38"			33					
39"	30							

Standard Specifications:

- Belt** - Endless "B" section V-belt.
- Frame** - 10 in. deep x 1 1/2 in. x 10 ga. galvanized steel channel frames with bolt on end couplers on head section. 8 in. deep x 1 1/2 in. x 10 ga. galvanized steel channel frames on spur.
- Roller** - 1.9 in. dia. x 16 ga. galvanized rollers on 3 in. centers. Grease-packed ball bearings.
- Floor Supports** - Adjustable 32 1/2 in. to 36 1/2 in. from floor to top of rollers. One support at end of conveyor.
- Driving Sheave** - 5 3/4 in. dia. V-belt sheave with 1 in. bore.
- Pressure Sheave** - 3 in. dia. V-belt sheave with 1/2 in. bore.
- Snub Return Sheave** - 3 in. dia. flat belt sheave with 1 in. bore.

- Take-Up** - Screw take-up with 4 in. dia. V-belt sheave with 1/2 in. bore. Provides take-up to allow for future belt tension.
- Bearings** - Sealed, pre-lubricated, self-aligning ball bearings.
- Conveying Speed** - Constant 60 FPM.
- Speed Reduction** - Sealed worm gear "C" face speed reducer with No. 50 chain to driving sheave.
- Motor** - 1/2 HP - 230/460 V - 3 Phase - 60 Hz. - totally enclosed, fan cooled.
- Electrical Controls** - Available as option.
- Capacity** - 500 lbs. total live load.

30° Straight Spur

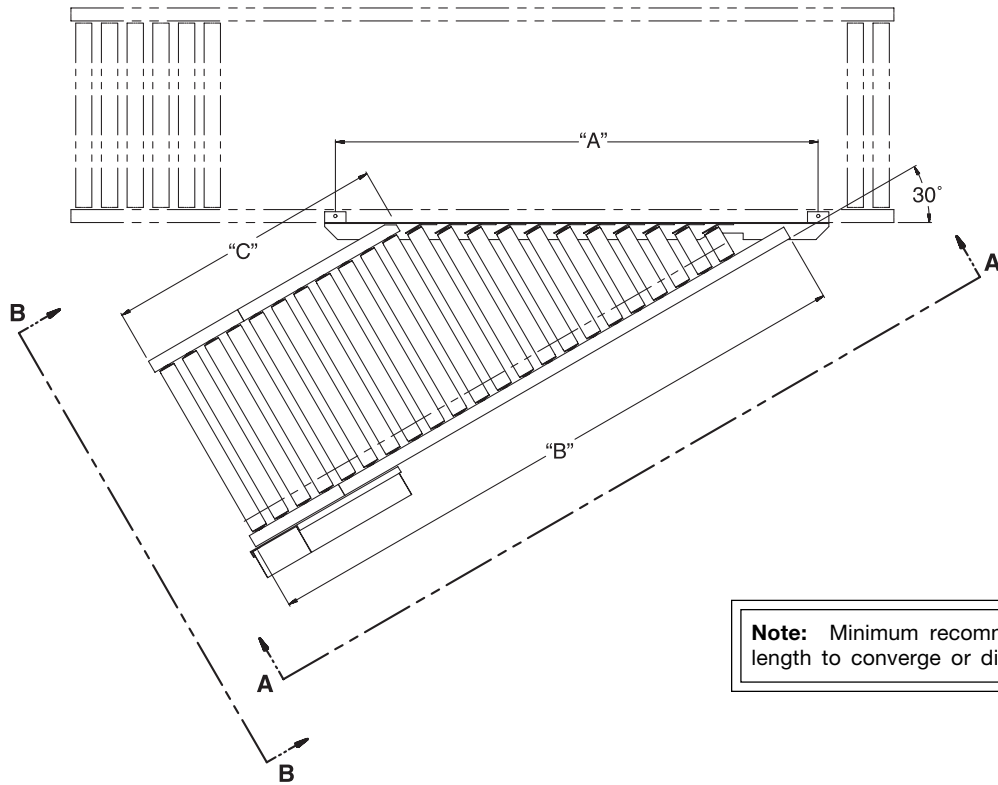

Note: Minimum recommended product length to converge or diverge product is 12".

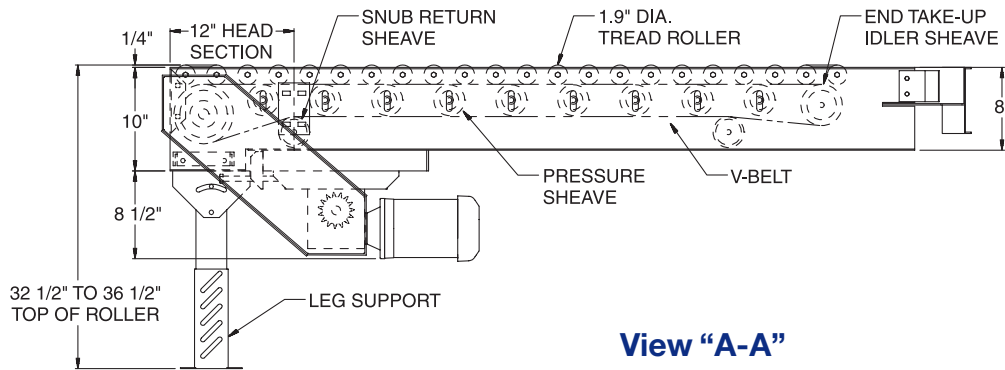

View "A-A"

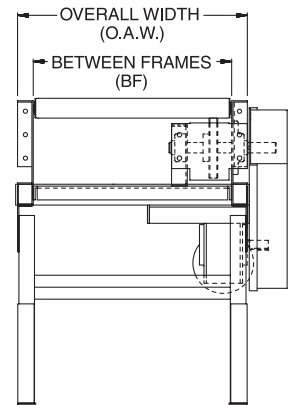

View "B-B"

Optional Equipment:

Conveying Speed - Constant and variable speeds available other than 60 FPM.

Fixed Angle Guard Rails - 1 1/2 in. x 2 in. formed 12 ga. galvanized angle. Other heights available. Channel types available. One or both sides. **Note: If product contacts guard rails, product flow may be affected.**

Floor Supports - Heights available up to 84 in. top of leg.

Ceiling Hangers - 5/8 in. x 10 ft. long threaded rod with mounting hardware. Other lengths available.

Traffic Cop - Controls product flow where two lines converge, eliminating product collisions. Only one line is open at a given time.

Turning Wheel - Used on converging lines to insure proper product orientation when product is transferred onto a main line.

Slave Driven - Spur to come less complete drive package and to be slaved to any belt driven live roller conveyor. (V-belt or flat belt.)

Other Drive Types - Shaft mount to allow lower top of belt.

Motors - Single phase, explosion proof, drip proof, DC motors, inverter duty, etc. Available through 2 HP.

Electrical Controls - Start/stop push-button station, reverse drum switch, one direction and reversible magnetic starters.

V-Belt Driven Live Roller Curve Spur Conveyor

11/16 in. dia. to 2 1/2 in. dia. x 14 ga. Zinc-Plated Tapered Rollers on Curve
1.9 in. dia. x 16 ga. Galvanized Straight Rollers on Spur and Tangent

The V-Belt Driven Live Roller Curve Spur Conveyor is a live roller spur used where product lines converge or diverge.

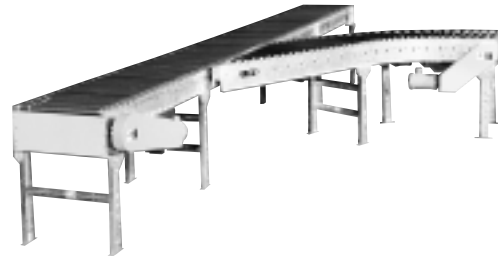

- Bolt-Together Construction
- 30° and 45° Spurs
- 10 in. x 1 1/2 in. x 10 ga. Galvanized Frame on Tangent, 8 in. x 1 1/2 in. x 10 ga. Galvanized Frame on Spur and Curve
- Between Frame Widths 13 in. Through 39 in.
- Self Powered or Slave Driven
- Tapered Rollers on Curve, Straight Rollers on Spur and Tangent
- Transportation Conveyor Only

V-BELT DRIVEN LIVE ROLLER CURVE SPUR CONVEYOR											
		30° SPUR					45° SPUR				
BETWEEN FRAME WIDTH	ROLLER CENTERS @ CENTERLINE	TAPERED ROLLERS PER SPUR	STRAIGHT ROLLERS PER SPUR	"A" (IN.)	"B" (IN.)	"C" (IN.)	TAPERED ROLLERS PER SPUR	STRAIGHT ROLLERS PER SPUR	"A" (IN.)	"B" (IN.)	"C" (IN.)
13"	2.781"	16	18	33 13/16	48	24	12	15	31 1/8	36	21
14"	2.814"	16									
15"	2.847"	16									
16"	2.880"	16									
17"	2.913"	16									
18"	2.945"	16	22	47 11/16	60	27	12	19	43 13/16	24	
19"	2.978"	16									
20"	3.011"	16									
21"	3.043"	16									
22"	3.076"	16									
23"	3.109"	16	26	61 9/16	72	24	12	23	48 1/16	21	
24"	3.142"	16									
25"	3.174"	16									
26"	3.207"	16									
27"	3.240"	16									
28"	3.272"	16	30	75 3/8	84	21	12	23	56 9/16	27	
29"	3.305"	16									
30"	3.338"	16									
31"	3.371"	16									
32"	3.403"	16									
33"	3.436"	16	34	84 1/16	87	18	12	23	60 7/8	24	
34"	3.469"	16									
35"	3.502"	16									
36"	3.534"	16									
37"	3.567"	16									
38"	3.600"	16	34	87 1/2	87	12	23	65 1/16	21		
39"	3.632"	16									

Standard Specifications:

Belt - Endless "B" section V-belt.

Frame - 10 in. deep x 1 1/2 in. x 10 ga. galvanized steel channel frames with bolt on end couplers on tangents. 8 in. deep x 1 1/2 in. x 10 ga. galvanized steel channel frames on spur and curve.

Outside rail of curve has "triple-punched" hex holes to allow skewing of rollers which affects product tracking.

Curve Roller - 2 1/2 in. dia. tapered to 1 11/16 in. dia. x 14 ga. zinc-plated rollers on 3 in. nom. centers. Grease-packed ball bearings. **Curve rollers do not represent true taper.**

Spur and Tangent Roller - 1.9 in. dia. x 16 ga. galvanized rollers on 3 in. centers. Grease-packed ball bearings.

Floor Supports - Adjustable 32 1/2 in. to 36 1/2 in. from floor to top of rollers. One support at both ends of curve.

Driving Sheave - 5 3/4 in. dia. V-belt sheave with 1 in. bore.

Pressure Sheave - 3 in. dia. V-belt sheave with 1/2 in. bore.

Snub Return Sheave - 3 in. dia. flat belt sheave with 1 in. bore.

Take-Up - Screw take-ups with 3 in. dia. V-belt sheave with 1/2 in. bore and 4 in. dia. V-belt sheave with 1/2 in. bore. Provides take-up to allow for future belt tension.

Bearings - Sealed, pre-lubricated, self-aligning ball bearings.

Conveying Speed - Constant 60 FPM.

Speed Reduction - Sealed worm gear "C" face speed reducer with No. 50 chain to driving sheave.

Motor - 1/2 HP - 230/460 V - 3 Phase - 60 Hz. - totally enclosed, fan cooled.

Electrical Controls - Available as option.

Capacity - 500 lbs. total live load.

30° Curve Spur

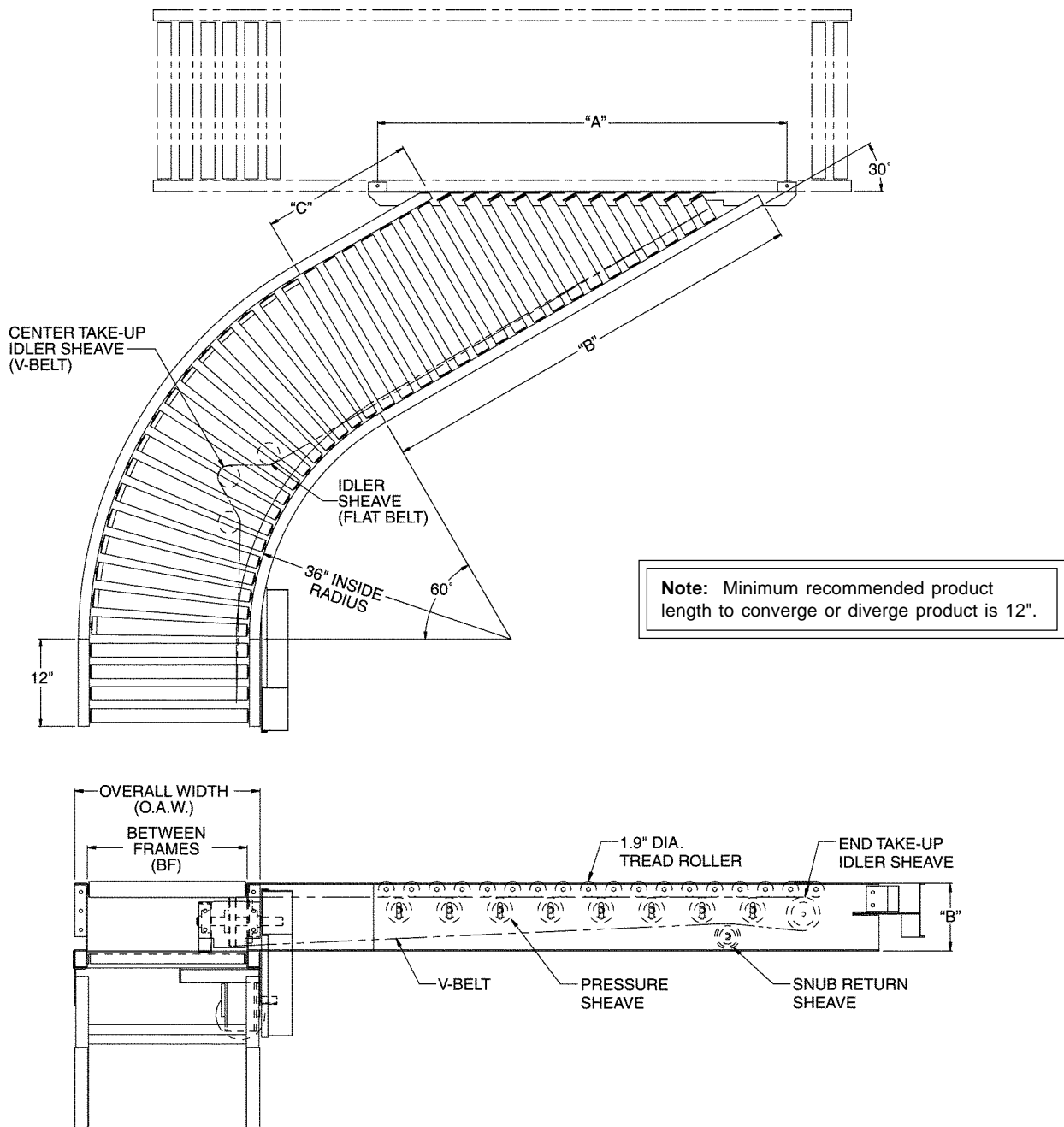

Optional Equipment:

Conveying Speed - Constant and variable speeds available other than 60 FPM.

Fixed Angle Guard Rails - 1 1/2 in. x 2 in. formed 12 ga. galvanized angle. Other heights available. Channel types available. One or both sides. **Note: If product contacts guard rails, product flow may be affected.**

Floor Supports - Heights available up to 84 in. top of leg.

Ceiling Hangers - 5/8 in. x 10 ft. long threaded rod with mounting hardware. Other lengths available.

Traffic Cop - Controls product flow where two lines converge, eliminating product collisions. Only one line is open at a given time.

Turning Wheel - Used on converging lines to insure proper product orientation when product is transferred onto a main line.

Slave Driven - Spur to come less complete drive package and to be slaved to any belt driven live roller conveyor. (V-belt or flat belt.)

Other Tangent Lengths - Tangent lengths 12 in. through 48 in. available.

True Tapered Roller Curve - True tapered roller curve available. Will require special radius or special rollers.

Other Drive Types - Shaft mount to allow lower top of belt.

Motors - Single phase, explosion proof, drip proof, DC motors, inverter duty, etc. Available through 2 HP.

Electrical Controls - Start/stop push-button station, reverse drum switch, one direction and reversible magnetic starters.

