

# 2200/2300 SERIES

LOW PROFILE BELT CONVEYORS  
EXTRUDED ALUMINUM

**PRECISION  
MOVE**   
2200 Series

**DustPruf**<sup>®</sup>  
  
2300 Series



## General Specifications:

- iDrive, Flat Belt End Drive, Cleated Belt End Drive and Center Drive models
- Gravity Roller models (2200 only)
- Modular Belt iDrive, End Drive and Mid Drive models
- Precision Move Flat Belt End Drive, Cleated Belt End Drive and Flat Belt Mid Drive models (2200 only)
- 1.25" (32 mm) diameter head and tail pulleys
- Widths: 2" (45 mm) to 24" (610 mm)
- Lengths: 1.5' (457 mm) to 30' (9,144 mm)
- Loads up to 200 lbs (90 kg)
- Optional Gang, Common or Slave Drive
- **CE** models available

## Applications:

- Small Part Transfers
- Part Accumulation
- Precision Part Movement
- Small Part Handling and Positioning
- Part/Package Infeed and Outfeed
- Automated and Manual Assembly



**V-Guided  
Belt Tracking**



**Optional Nose  
Bar Transfer**



**Rack and Pinion  
Belt Tensioning**

<b>2200 / 2300 SERIES</b>	iDRIVE	<b>10</b>
	FLAT BELT END DRIVE	<b>12</b>
	FLAT BELT CENTER DRIVE	<b>14</b>
	CLEATED BELT END DRIVE	<b>16</b>
	2200 SERIES GRAVITY ROLLER	<b>18</b>
	<b>MB SERIES</b>	MODULAR BELT iDRIVE
	MODULAR BELT END DRIVE	<b>22</b>
	MODULAR BELT CENTER DRIVE	<b>24</b>
<b>PRECISION MOVE</b>	FLAT & CLEATED BELT END DRIVE	<b>26</b>
	FLAT BELT MID DRIVE	<b>28</b>
	SLAVE, COMMON, AND GANG DRIVE	<b>30</b>
	SERVO GEARMOTOR & ACCESSORIES	<b>33</b>
	PROFILES	<b>35</b>
	BELTING	<b>37</b>
	GEARMOTOR MOUNTING PACKAGES	<b>40</b>
	GEARMOTORS	<b>53</b>
	SUPPORT STANDS	<b>62</b>
	ACCESSORIES	<b>68</b>
	PART NUMBER REFERENCE	<b>74</b>

# 2200 & 2300 SERIES: iDRIVE



## Specifications:

- Sealed ball bearings
- Belt Widths: 2" (51 mm) to 18" (457 mm)
- Conveyor Lengths: 18" (457 mm) to 8' (2,438 mm)
- Belt Speeds: Variable Speed, (4) Speed Options
  - 1.7 to 17 ft/min (0.5 to 5 m/min)
  - 3 to 24 ft/min (0.9 to 7 m/min)
  - 5 to 50 ft/min (1.5 to 15 m/min)
  - 7 to 70 ft/min (2 to 21 m/min)
- Conveyor Load Capacity (non-accumulated, distributed load):
  - 1.7 to 17 ft/min – Up to 25 lbs (11.3 kg)
  - 3 to 24 ft/min – Up to 25 lbs (11.3 kg)
  - 5 to 50 ft/min – Up to 25 lbs (11.3 kg)
  - 7 to 70 ft/min – Up to 12 lbs (5.4 kg)
- Indexing Capable – Up to 30 indexes per minute

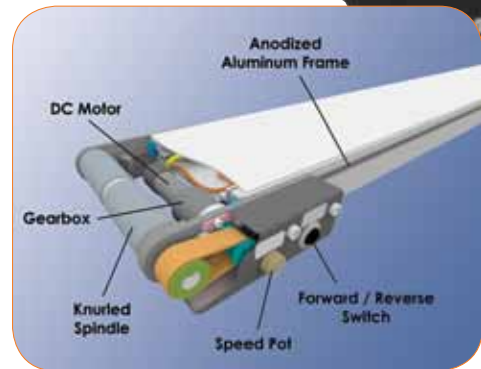

## Features & Benefits:

- Internally mounted gearmotor and control for space savings and tight work spaces
- Reduced integration time required to mount and wire the total conveyor package
- Ideal combination of conveyor and gearmotor sizing for small parts handling
- Variable Speed and reversible for maximum application flexibility
- Control switches conveniently located in high impact protective case
- 1.25" diameter drive roller for smooth product transfer
- V-guided belts for maintenance-free belt tracking (4" and wider only)
- Maintenance-free brushless DC motor



### OPTIONAL: Customer Wired Controls

For ease of automation integration.



### OPTIONAL: 8 mm Nose Bar Transfer

Available at non-driven end.  
Speeds up to 75 ft/min (22 m/min).

### Two Side Rail Options:

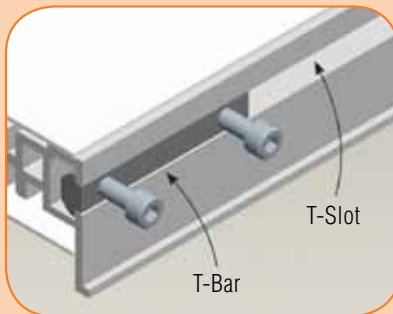

**2200 T-Slot Technology:**  
Drop in T-bar for ease and flexibility  
in mounting accessories

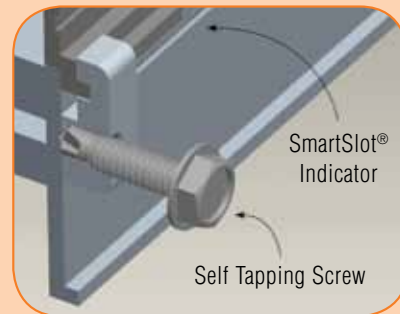

**2300 SmartSlot® Technology:**  
Functions like a T-Slot without  
collecting debris

For support stands and accessories, see pages 62-73.

For ordering information, see page 74

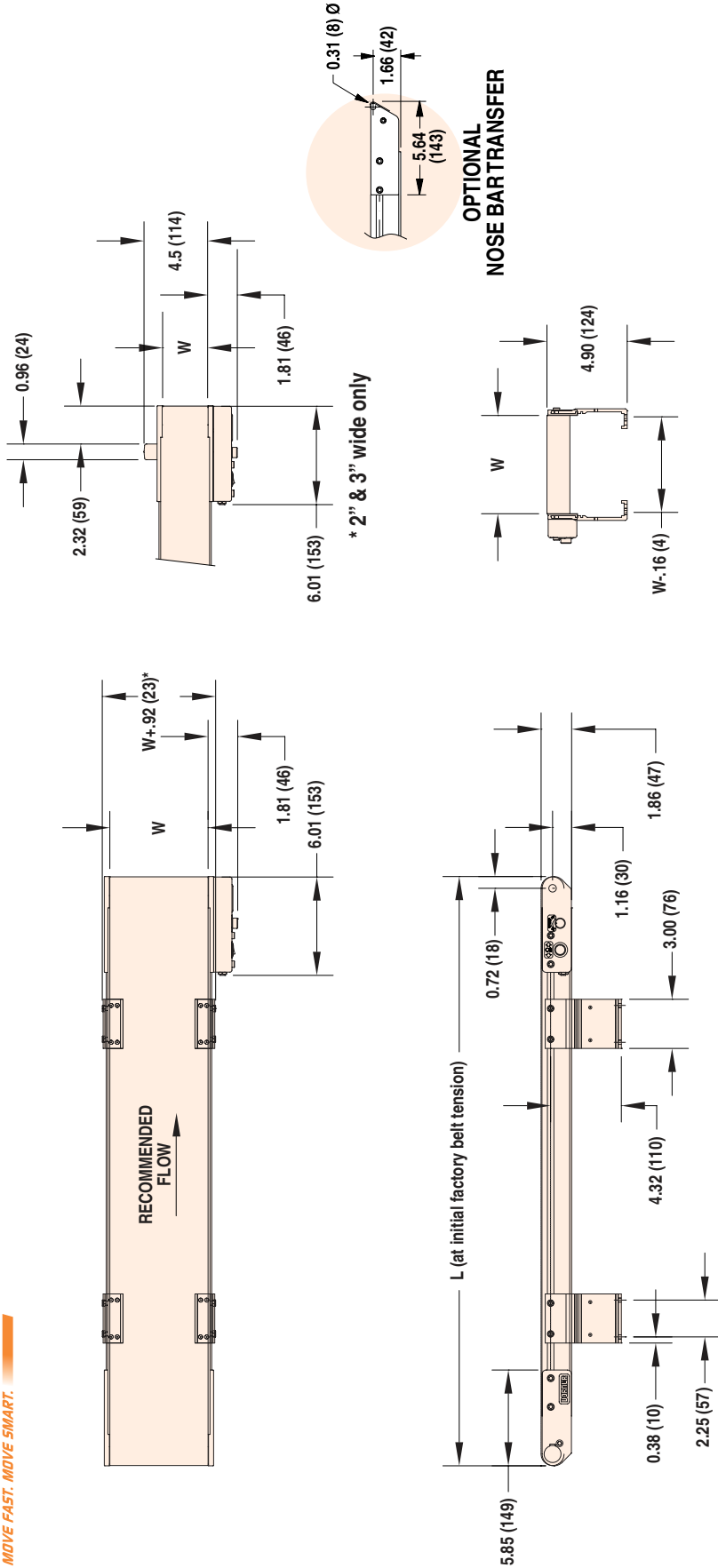

**W** = Conveyor Belt Width **Dim** = in (mm)

STANDARD SIZES									
<b>Conveyor Width Reference</b>	02	03	04	05	06	08	10	12	18
<b>Conveyor Belt Width (W)</b>	1.75" (44mm)	2.75" (70mm)	3.75" (95mm)	5" (127mm)	6" (152mm)	8" (203mm)	10" (254mm)	12" (305mm)	18" (457mm)
<b>Conveyor Length Reference</b>	0150		0001 increments up to...						
<b>Conveyor Length (L)</b>	1.5' (457mm)		0.12" (3mm) increments up to... 8' (2,438mm)						

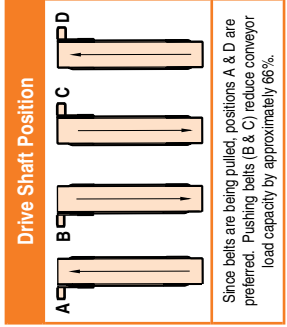

For more information, go to [www.dorner.com](http://www.dorner.com). Call 800.397.8664 or 262.367.7600.  
Due to the wide variety of drive set ups and applications, point of installation guarding is the responsibility of the end user.

# 2200 & 2300 SERIES: FLAT BELT END DRIVE



## Specifications:

- Loads up to 80 lbs\* (36 kg)
- Belt speeds up to 400 ft/min (122 m/min)
- Belt widths: 1.75" (44 mm) to 24" (610 mm)
- Conveyor lengths: 18" (457 mm) to 18' (5,486 mm)
- 1.25" (32 mm) diameter drive and idler pulleys turn approximately 4.2" (107 mm) of belt per revolution
- V-groove stainless steel bedplate
- 12 mm diameter integral drive shaft
- CE models available

\* Conveyor load capacity depends on conveyor size, incline, motor position, accumulated loads and other factors.



**OPTIONAL:  
8 mm Nose Bar Transfer**

Available at non-driven end.  
Speeds up to 75 ft/min (22 m/min).

## Features & Benefits:

- Quick five-minute belt change
- Rack and pinion belt tensioning for fast, accurate single-point belt tensioning
- Aluminum die cast head plates eliminate painted surfaces
- V-groove bedplate with guided belt provides positive belt tracking, even under demanding side load applications
- Non V-guided belts use our patented belt tracking cams, offering you the widest belt selection possible
- Strong, box-like construction resists damaging frame twist
- 50% more belt take-up extends conveyor belt life
- Belt take-up indicators for "at a glance" readings of remaining belt life
- T-slots make mounting accessories simple with no drilling or special tools (2200)
- Stand mounting brackets are easily re-positioned along the T-slot (2200)
- SmartSlot® mounting system for attachments feature clean sides (2300)
- Motion sensor switch ready
- Sealed ball bearings

### Two Side Rail Options:

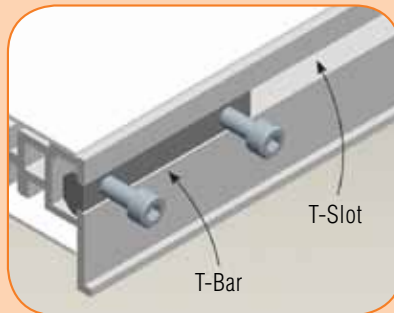

**2200 T-Slot Technology:**  
Drop in T-bar for ease and flexibility in mounting accessories

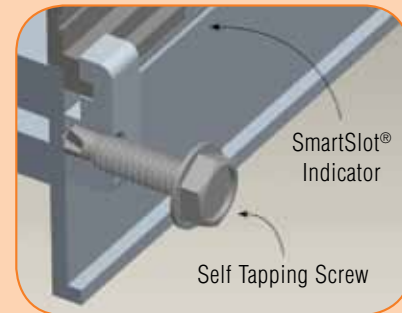

**2300 SmartSlot® Technology:**  
Functions like a T-Slot without collecting debris



**OPTIONAL:  
Dual or Idler End  
Output Shafts**

Order gearmotor mounting packages and gearmotors separately, see pages 40-61.  
For support stands and accessories, see pages 62-73.

For ordering information, see page 74

**2200 & 2300 SERIES: FLAT BELT END DRIVE**

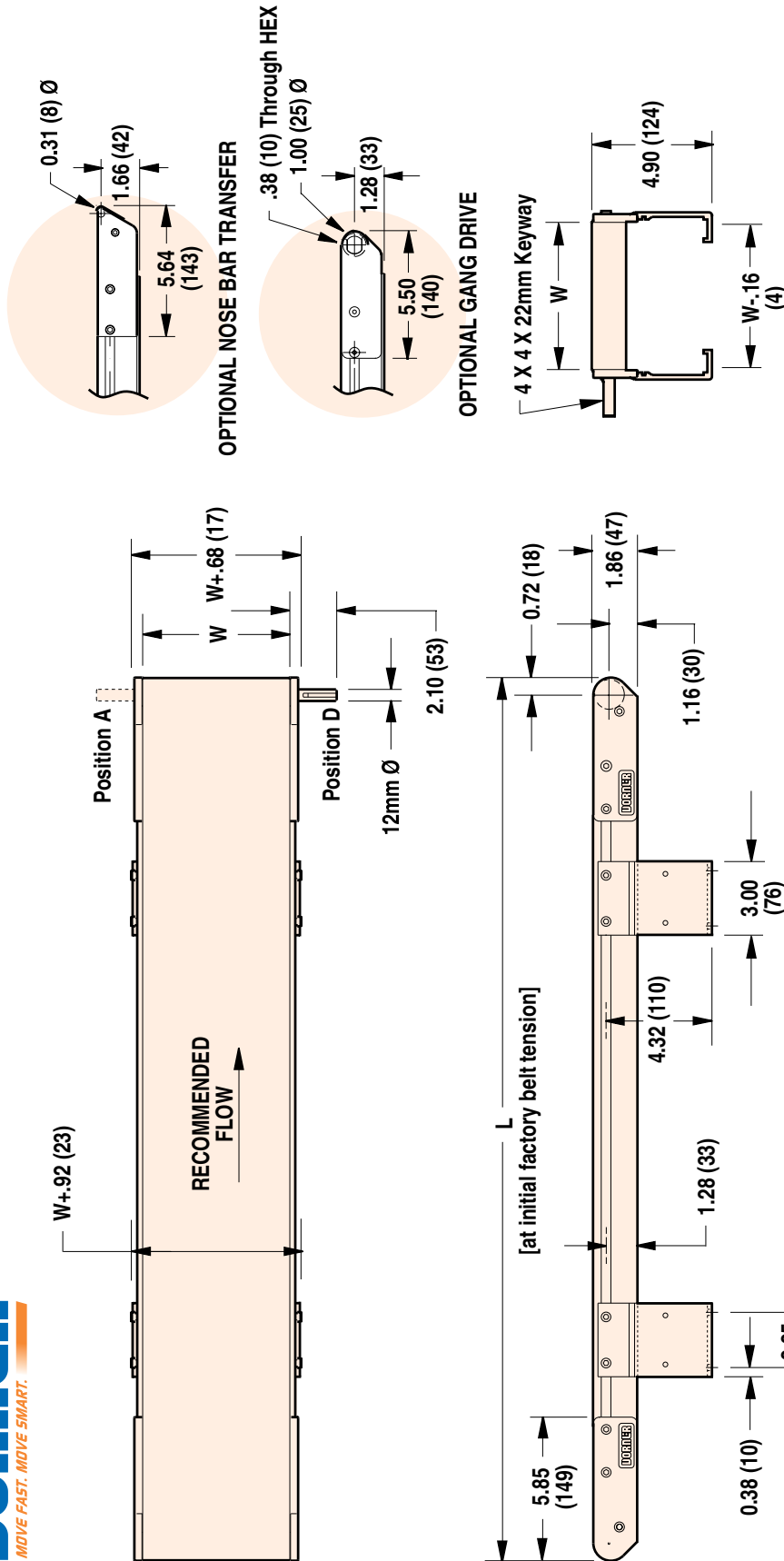

W = Conveyor Belt Width Dim = in (mm)

STANDARD SIZES											
Conveyor Width Reference	02	03	04	05	06	08	10	12	18	21	24
Conveyor Belt Width (W)	1.75" (44mm)	2.75" (70mm)	3.75" (95mm)	5" (127mm)	6" (152mm)	8" (203mm)	10" (254mm)	12" (305mm)	18" (457mm)	21" (533mm)	24" (610mm)
Conveyor Length Reference	0150										
Conveyor Length (L)	1.5' (457mm)										
	0.12" (3mm) increments up to...										
	18' (5.486mm)										

NOTE: Lengths 13' to 18' available in widths 6" to 24" only.

NOTE: Conveyor longer than 12' (3.658 mm) will be constructed using a multiple piece frame. Consult factory for locations.

Gang Drive Conveyors: Non-V-guided belts up to 24" (610 mm) wide, V-Guided belts up to 18" (457 mm) wide.

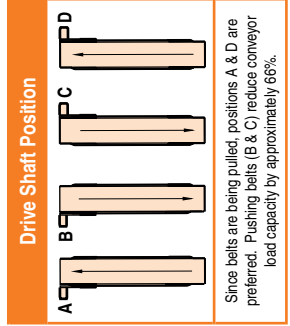

Since belts are being pulled, positions A & D are preferred. Pushing belts (B & C) reduce conveyor load capacity by approximately 66%.

# 2200 & 2300 SERIES: FLAT BELT CENTER DRIVE



## Specifications:

- Loads up to 120 lbs\* (54 kg)
- Belt speeds up to 400 ft/min (122 m/min)
- Belt widths: 1.75" (44 mm) to 24" (610 mm)
- Conveyor lengths: 24" (610 mm) to 24' (7,315 mm)
- 1.25" (32 mm) diameter drive and idler pulleys turn approximately 4.2" (107 mm) of belt per revolution
- V-groove stainless steel bedplate
- 12 mm diameter integral drive shaft
- CE models available

\* Conveyor load capacity depends on conveyor size, incline, motor position, accumulated loads and other factors.



**COMING SOON:**  
Compact Mid Drive

Contact factory for details.

## Features & Benefits:

- Center Drive module frees up both ends of conveyor for operator and machine interface
- Center Drive module can be easily repositioned along the length of the conveyor
- Maintenance-free gas-spring belt tensioner maintains uniform belt tension
- Aluminum die-cast head plates eliminate painted end surfaces
- V-groove bedplate with guided belt provides positive belt tracking, even under demanding side load applications
- Non V-guided belts use our patented belt tracking cams, offering you the widest belt selection possible
- Strong, box-like construction resists damaging frame twist
- 2" (51 mm) of belt take up extends conveyor belt life
- T-slots make mounting accessories simple with no drilling or special tools (2200)
- Stand mounting brackets are easily re-positioned along the T-slot (2200)
- SmartSlot® mounting system for attachments feature clean sides (2300)
- Motion sensor switch ready
- Sealed ball bearings



**OPTIONAL:**  
8mm Nose Bar Transfer

Available at either end.  
Belt Speed up to 75 ft/min (22 m/min).

### Two Side Rail Options:

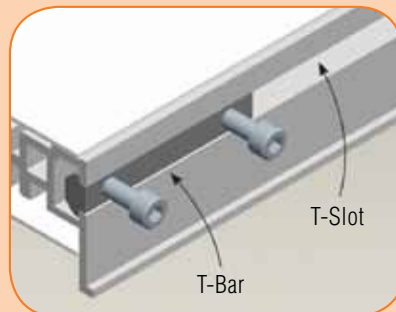

**2200 T-Slot Technology:**  
Drop in T-bar for ease and flexibility in mounting accessories

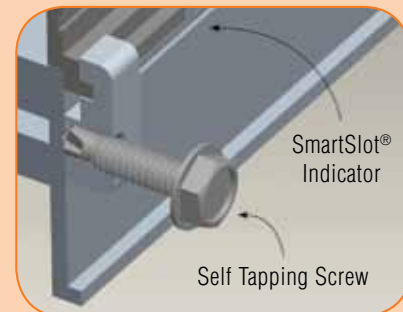

**2300 SmartSlot® Technology:**  
Functions like a T-Slot without collecting debris

Order gearmotor mounting packages and gearmotors separately, see pages 40-61.  
For support stands and accessories, see pages 62-73.

For ordering information, see page 75

**2200 & 2300 SERIES: FLAT BELT CENTER DRIVE**

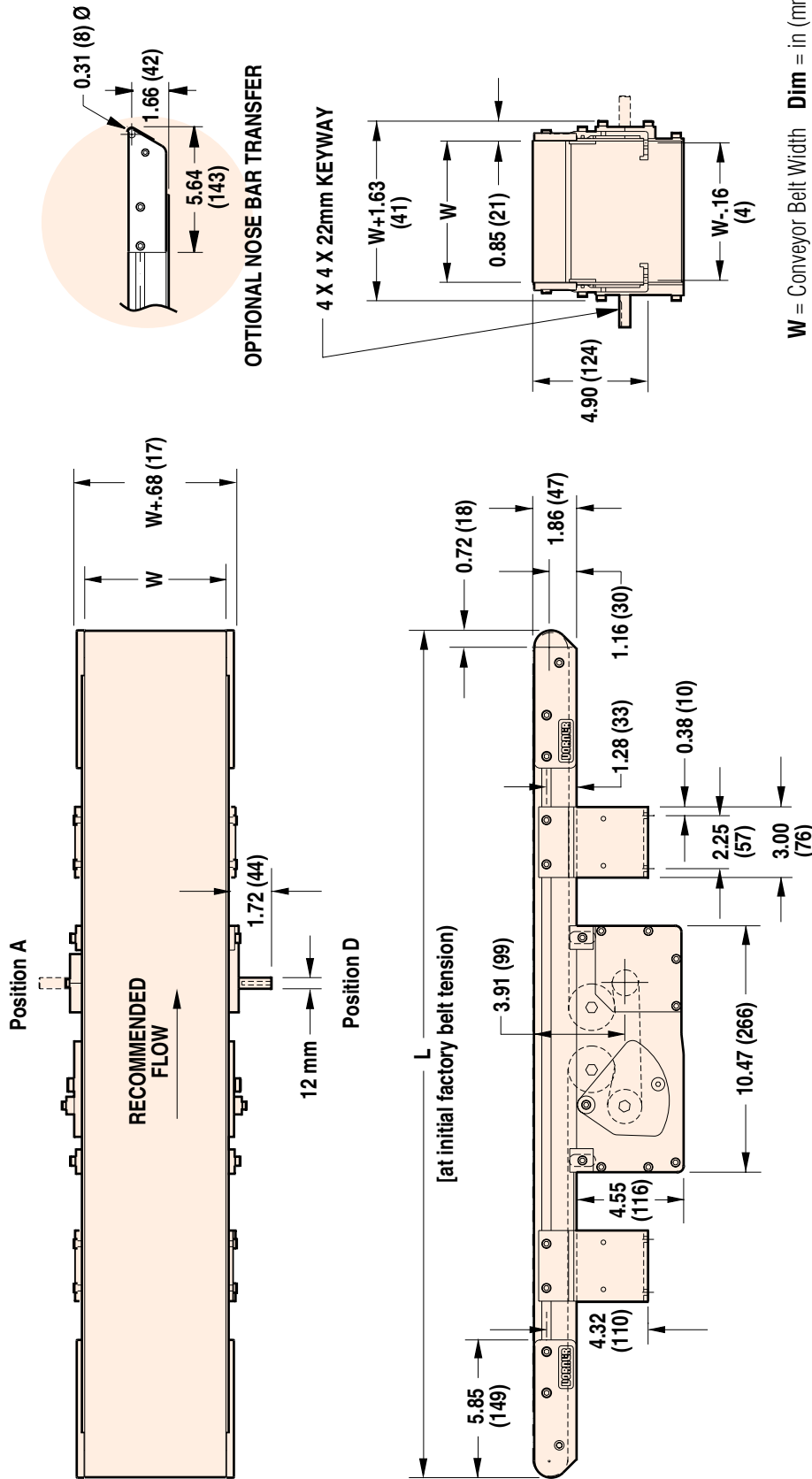

W = Conveyor Belt Width Dim = in (mm)

STANDARD SIZES											
Conveyor Width Reference	02	03	04	05	06	08	10	12	18	21	24
Conveyor Belt Width (W)	1.75" (44mm)	2.75" (70mm)	3.75" (95mm)	5" (127mm)	6" (152mm)	8" (203mm)	10" (254mm)	12" (305mm)	18" (457mm)	21" (533mm)	24" (610mm)
Conveyor Length Reference	0200										
Conveyor Length (L)	2' (610mm)										
	0.12" (3mm) increments up to...										
	24' (7.315mm)										

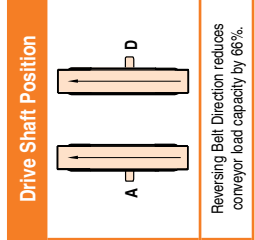

NOTE: Lengths 13' to 18' available in widths 6" to 24" only.  
 NOTE: Conveyor longer than 12' (3,658 mm) will be constructed using a multiple piece frame. Consult factory for locations.  
 Gang Drive Conveyors: Non-V-guided belts up to 24" (610 mm) wide, V-Guided belts up to 18" (457 mm) wide.

For more information, go to [www.dorner.com](http://www.dorner.com). Call 800.397.8664 or 262.367.7600.  
 Due to the wide variety of drive set ups and applications, point of installation guarding is the responsibility of the end user.



# 2200 & 2300 SERIES: CLEATED BELT END DRIVE



## Specifications:

- Loads up to 80 lbs\* (36 kg)
- Belt speeds up to 400 ft/min (122 m/min)
- Belt widths: 1.75" (44 mm) to 24" (610 mm)
- Conveyor lengths: 18" (457 mm) to 18' (5,486 mm)
- Cleats available from 0.24" (6 mm) to 2.36" (60 mm) high
- 1.25" (32 mm) diameter drive and idler pulleys turn approximately 4.2" (107 mm) of belt per revolution
- V-groove stainless steel bedplate
- 12 mm diameter integral drive shaft
- CE models available

\* Conveyor load capacity depends on conveyor size, incline, motor position, accumulated loads and other factors.

**Note:** Standard idler pulley houses a small magnet which may be omitted upon request for magnetically sensitive products and applications.

## Features & Benefits:

- Quick five-minute belt change
- Rack and pinion belt tensioning for fast, accurate single point belt tensioning
- Aluminum die cast head plates eliminate painted surfaces
- V-groove bedplate with guided belt provides positive belt tracking, even under demanding side load applications
- Non V-guided belts use our patented belt tracking cams, offering you the widest belt selection possible
- Strong, box-like construction resists damaging frame twist
- 50% more belt take-up extends conveyor belt life
- T-slots make mounting accessories simple with no drilling or special tools (2200)
- Stand mounting brackets are easily re-positioned along the T-slot (2200)
- SmartSlot® mounting system for attachments feature clean sides (2300)
- Motion sensor ready
- Sealed ball bearings

### Two Side Rail Options:

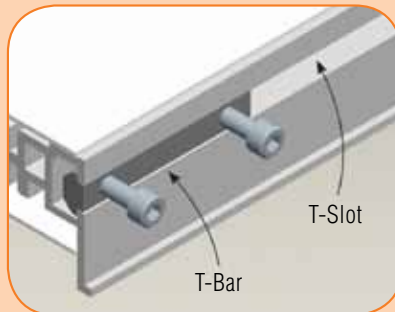

**2200 T-Slot Technology:**  
Drop in T-bar for ease and flexibility in mounting accessories

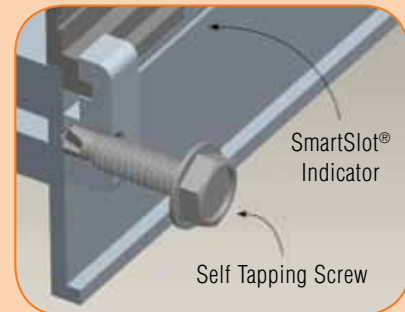

**2300 SmartSlot® Technology:**  
Functions like a T-Slot without collecting debris



**OPTIONAL:**  
Dual or Idler End  
Output Shafts

Order gearmotor mounting packages and gearmotors separately, see pages 40-61.  
For support stands and accessories, see pages 62-73.

For ordering information, see page 75

**2200 & 2300 SERIES: CLEATED BELT END DRIVE**

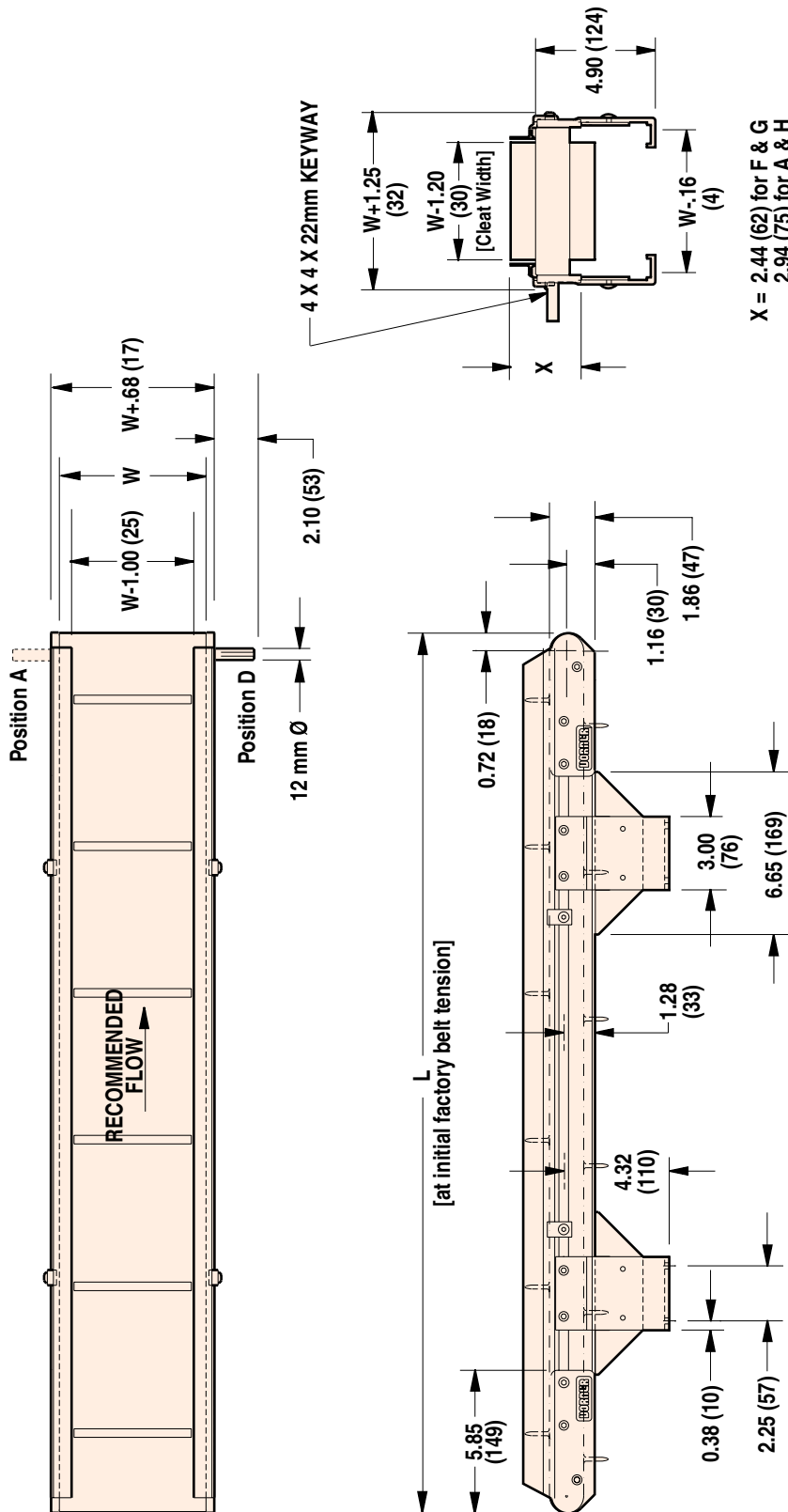

X = 2.44 (62) for F & G  
2.94 (75) for A & H  
4.14 (105) for B, C, V & J cleats

W = Conveyor Belt Width Dim = in (mm)

**STANDARD SIZES**

Conveyor Width Reference	02	03	04	05	06	08	10	12	18	21	24
Conveyor Belt Width (W)	1.75" (44mm)	2.75" (70mm)	3.75" (95mm)	5" (127mm)	6" (152mm)	8" (203mm)	10" (254mm)	12" (305mm)	18" (457mm)	21" (533mm)	24" (610mm)
Conveyor Length Reference	0150										
Conveyor Length (L)	1.5' (457mm)										
	0.12" (3mm) increments up to...										
	18' (5.486mm)										

NOTE: Lengths 13' to 18' available in widths 6" to 24" only.

NOTE: Conveyor longer than 12' (3.658 mm) will be constructed using a multiple piece frame. Consult factory for locations.

Gang Drive Conveyors: Non-V-guided belts up to 24" (610 mm) wide, V-Guided belts up to 18" (457 mm) wide.

**Drive Shaft Position**

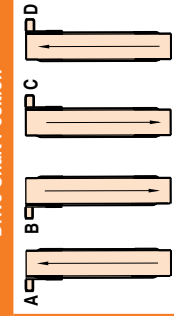

Since belts are being pulled, positions A & D are preferred. Pushing belts (B & C) reduce conveyor load capacity by approximately 66%.

# 2200 SERIES: GRAVITY ROLLER



## Specifications:

- Loads up to 80 lbs/ft\* (119 kg/m)
- Conveyor widths: 6" (152 mm), 12" (305 mm), 18" (457 mm) and 24" (610 mm)
- Conveyor lengths: 2' (610 mm) to 12' (3,658 mm) in 6" (152 mm) increments
- Rollers: 1" (25 mm) diameter rollers on 1.2" (31 mm), 2.4" (61 mm) or 3.6" (91 mm) centers
- Roller material: Anodized aluminum tube with steel ball bearing
- Side T-slot fits Dorner drop in hardware
- Lower T-slot fits standard M6 square nuts

\* Conveyor load capacity depends on conveyor size, incline, accumulated loads and other factors.

## Features & Benefits:

- 1" roller on 1.2" centers – better small part handling
- 44% stronger while 42% lighter
- Standard lengths available in 6" increments
- Single piece frame lengths to 12' long
- Lower T-slot integrates with stand, eliminating the need for mounting brackets
- Lower cost with better performance



**OPTIONAL:  
End Stop**

### Roller Quantity

Length	Roller Centers					
	1.2" (31mm)		2.4" (61mm)		3.6" (91mm)	
	# of Rollers	Load Capacity (lbs/ft)	# of Rollers	Load Capacity (lbs/ft)	# of Rollers	Load Capacity (lbs/ft)
2' (610)	20	80	11	50	8	40
3' (914)	30	80	16	50	12	40
4' (1,219)	40	80	21	50	16	40
5' (1,524)	50	80	26	50	20	40
6' (1,829)	60	80	31	50	24	40
7' (2,134)	70	80	36	50	28	40
8' (2,438)	80	80	41	50	32	40
9' (2,743)	90	80	46	50	36	40
10' (3,048)	100	80	51	50	40	40
11' (3,353)	110	80	56	50	44	40
12' (3,658)	120	80	61	50	48	40

**NOTE:** It is recommended that 3 rollers be in contact with the product at all times.

For support stands and accessories, see pages 62-73.

For ordering information, see page 76

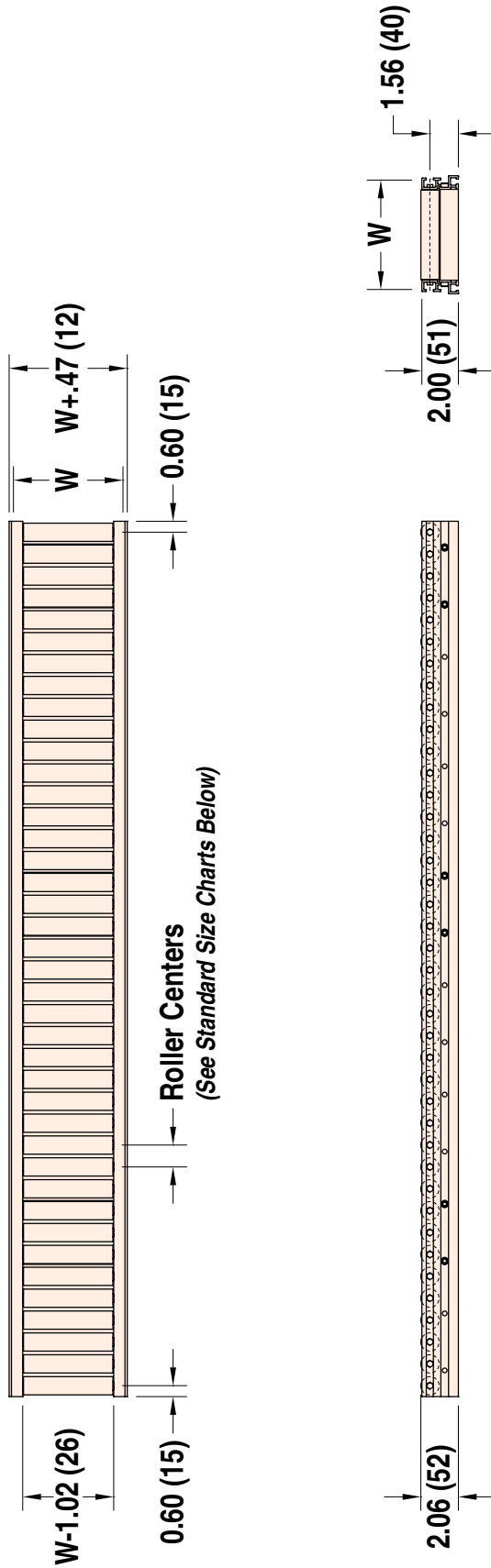

All conveyors are shipped with a roller at each end. Depending on roller centers, one odd roller space may occur.  
All frames are punched for rollers 0.6" (15) from each end on 1.2" (31) centers

**W** = Conveyor Width **Dim** = in (mm)

STANDARD SIZES				
Conveyor Width Reference	06	12	18	24
Conveyor Frame Width (W)	6" (152mm)	12" (305mm)	18" (457mm)	24" (610mm)
Conveyor Roller Width (inch)	5" (127mm)	11" (279mm)	17" (432mm)	23" (584mm)
Conveyor Length Reference (LLLL)	0200	0050 increments up to ...		1200
Conveyor Length (feet)	2' (610mm)	0.5' (152mm) increments up to ...		12' (3,658mm)
Roller Center Reference (SS)	12	24	36	
Roller Centers (inch)	1.2" (31mm)	2.4" (61mm)	3.6" (91mm)	

# 2200 & 2300 SERIES: MODULAR BELT iDRIVE



## Specifications:

- Sealed ball bearings
- Belt widths: 4" (102 mm), 8" (203 mm), 12" (305 mm), 24" (610 mm)
- Conveyor Lengths: 18" (457 mm) to 10' (3,048 mm)
- Belt Speeds: Variable Speed, (4) Speed Options
  - 2 to 20 ft/min (0.6 to 6.1 m/min)
  - 2.8 to 28 ft/min (0.9 to 8.5 m/min)
  - 6 to 69 ft/min (1.8 to 21 m/min)
  - 8 to 82 ft/min (2.4 to 25 m/min)
- Conveyor Load Capacity (non-accumulated, distributed load):
  - 2 to 20 ft/min – Up to 75 lbs (34 kg)
  - 2.8 to 28 ft/min – Up to 65 lbs (29 kg)
  - 6 to 69 ft/min – Up to 45 lbs (20 kg)
  - 8 to 82 ft/min – Up to 25 lbs (11.3 kg)
- Indexing Capable – Up to 30 indexes per minute

\* Conveyor load capacity depends on conveyor size, incline, motor position, accumulated loads and other factors.



Belt Speed up to 175 ft/min (53.3 m/min).

## Features & Benefits:

- Internally mounted gearmotor and control for space savings and tight work spaces
- Reduced integration time required to mount and wire the total conveyor package
- Ideal combination of conveyor and gearmotor sizing for small parts handling
- Variable Speed for maximum application flexibility
- Control switches conveniently located in high impact protective case
- 1.5" diameter drive roller for smooth product transfer
- 0.33" (8 mm) pitch modular belt for small part handling and smooth operation
- T-Slots make mounting accessories simple with no drilling or special tools (2200)
- Stand mounting brackets are easily re-positioned along the T-Slot (2200)
- SmartSlot® mounting system for attachments feature clean sides (2300)
- Maintenance-free brushless DC motor

### Two Side Rail Options:

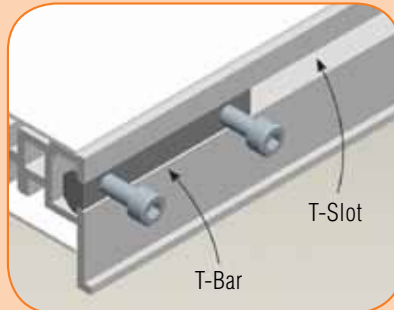

**2200 T-Slot Technology:**  
Drop in T-bar for ease and flexibility in mounting accessories

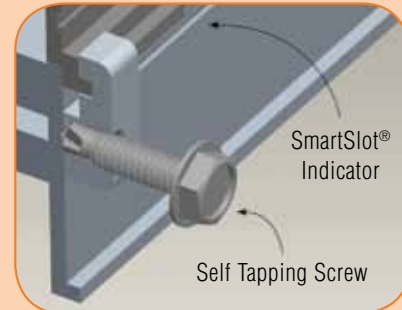

**2300 SmartSlot® Technology:**  
Functions like a T-Slot without collecting debris

*Order gearmotor mounting packages and gearmotors separately, see pages 40-61.  
For support stands and accessories, see pages 62-73.*

**For ordering information, see page 76**

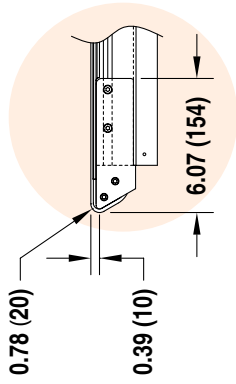
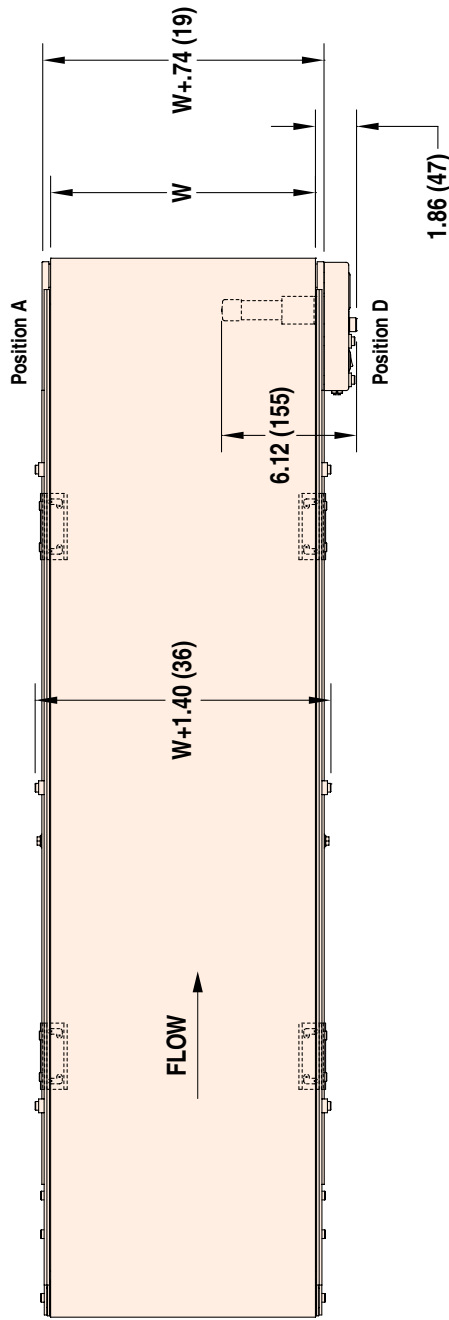

**OPTIONAL NOSE  
BAR TRANSFER**

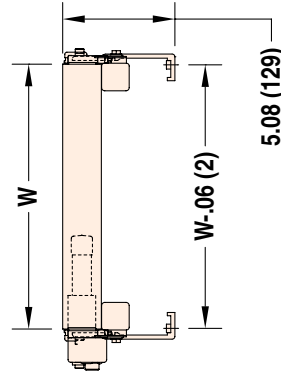
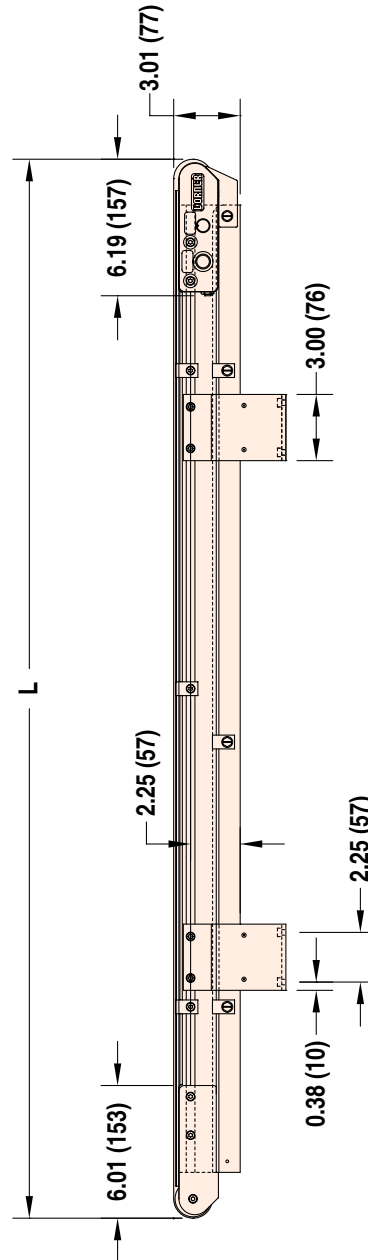

W = Conveyor Belt Width Dim = in (mm)

**DRIVE SHAFT POSITION**

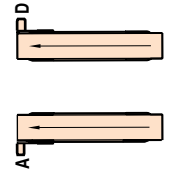

**STANDARD SIZES**

Conveyor Width Reference	04	08	12	24
Conveyor Frame Width (W)	4.1" (104mm)	8.1" (206mm)	12.1" (307mm)	24.1" (612mm)
Conveyor Length Reference	0150	0001 increments up to...		1000
Conveyor Length (L)	18" (457mm)	0.1" (3mm) increments up to...		10' (3,048mm)

For more information, go to [www.dorner.com](http://www.dorner.com). Call 800.397.8664 or 262.367.7600.  
Due to the wide variety of drive set ups and applications, point of installation guarding is the responsibility of the end user.

# 2200 & 2300 SERIES: MODULAR BELT END DRIVE



## Specifications:

- Loads up to 150 lbs\* (68 kg)
- Belt speeds up to 250 ft/min (76 m/min)
- Belt widths: 4" (102 mm), 8" (203 mm), 12" (305 mm), 24" (610 mm)
- Conveyor lengths: 18" (457 mm) to 30' (9,144 mm)
- 1.5" (38 mm) pitch diameter 15 tooth drive pulley turns approximately 4.7" (121 mm) of belt per revolution
- 0.33" (8 mm) micro pitch modular belt
- 12 mm diameter integral drive shaft
- Belt return system is full length UHMW support
- CE models available

\* Conveyor load capacity depends on conveyor size, incline, motor position, accumulated loads and other factors.



OPTIONAL:  
0.31" Nose Bar Transfer

Belt Speed up to 175 ft/min (53.3 m/min).

## Features & Benefits:

- 0.33" (8 mm) pitch modular belt for small part handling and smooth operation
- Modular belt features a flat belt surface ideal for inspection and label applications
- Aluminum die cast head plates eliminate painted surfaces
- Sprocket driven belt and side guides provide worry free belt tracking
- Strong, box-like construction resists damaging frame twist
- T-Slots make mounting accessories simple with no drilling or special tools (2200)
- Stand mounting brackets are easily re-positioned along the T-Slot (2200)
- SmartSlot® mounting system for attachments feature clean sides (2300)
- Sealed ball bearings

### Two Side Rail Options:

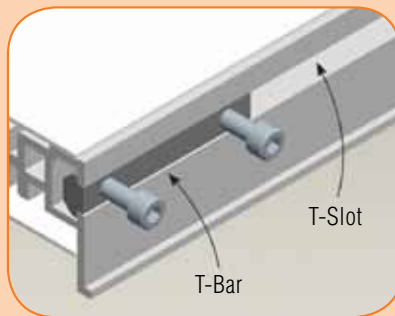

**2200 T-Slot Technology:**  
Drop in T-bar for ease and flexibility in mounting accessories

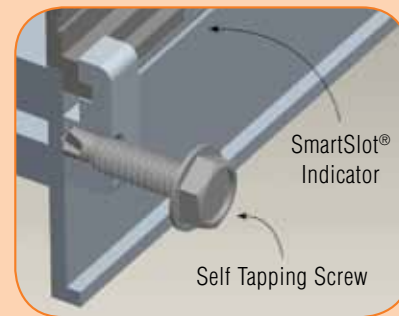

**2300 SmartSlot® Technology:**  
Functions like a T-Slot without collecting debris

Order gearmotor mounting packages and gearmotors separately, see pages 40-61.  
For support stands and accessories, see pages 62-73.

For ordering information, see page 76

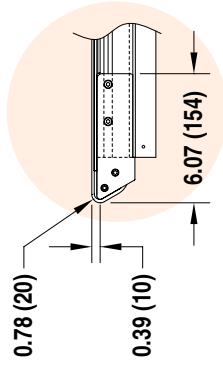
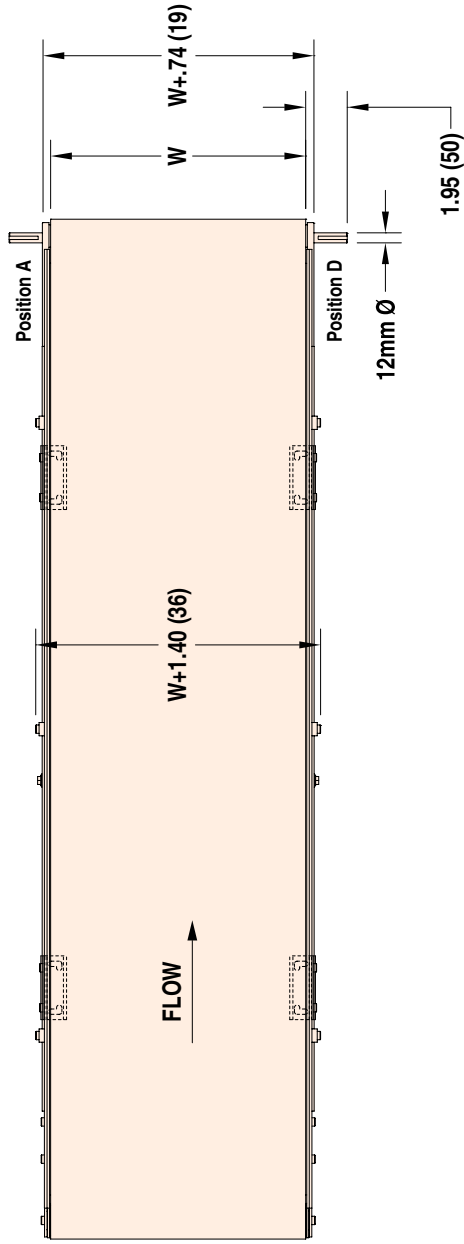

**OPTIONAL NOSE  
BAR TRANSFER**

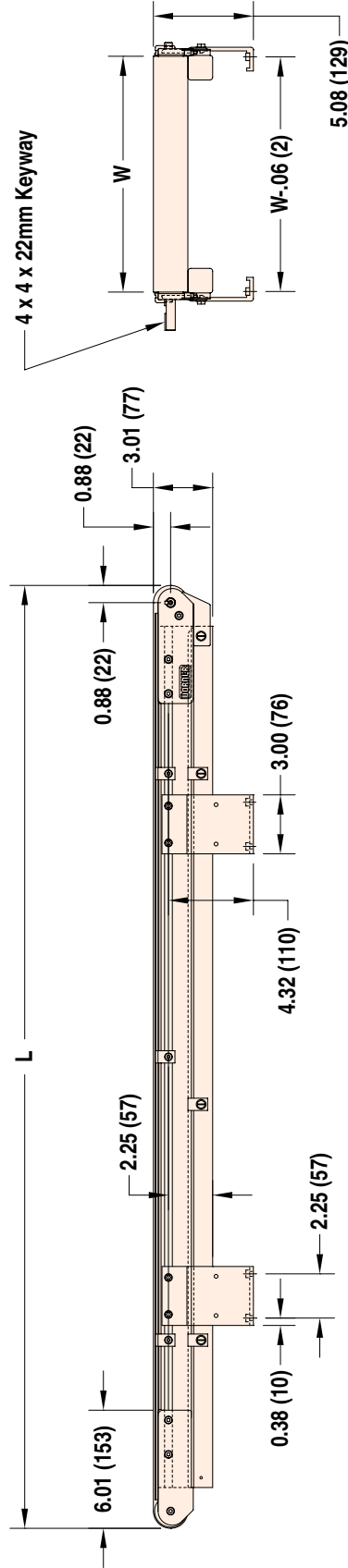

**STANDARD SIZES**

<b>Conveyor Width Reference</b>	04	08	12	24
<b>Conveyor Frame Width (W)</b>	4.1" (104mm)	8.1" (206mm)	12.1" (307mm)	24.1" (612mm)
<b>Conveyor Length Reference</b>	0150	0001 increments up to...		3000
<b>Conveyor Length (L)</b>	18" (457mm)	0.1" (3mm) increments up to...		30' (9,144mm)

**DRIVE SHAFT POSITION**

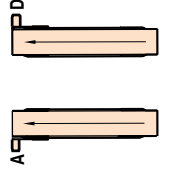

W = Conveyor Belt Width Dim = in (mm)

For more information, go to [www.dorner.com](http://www.dorner.com). Call 800.397.8664 or 262.367.7600.  
Due to the wide variety of drive set ups and applications, point of installation guarding is the responsibility of the end user.



# 2200 & 2300 SERIES: MODULAR BELT CENTER DRIVE

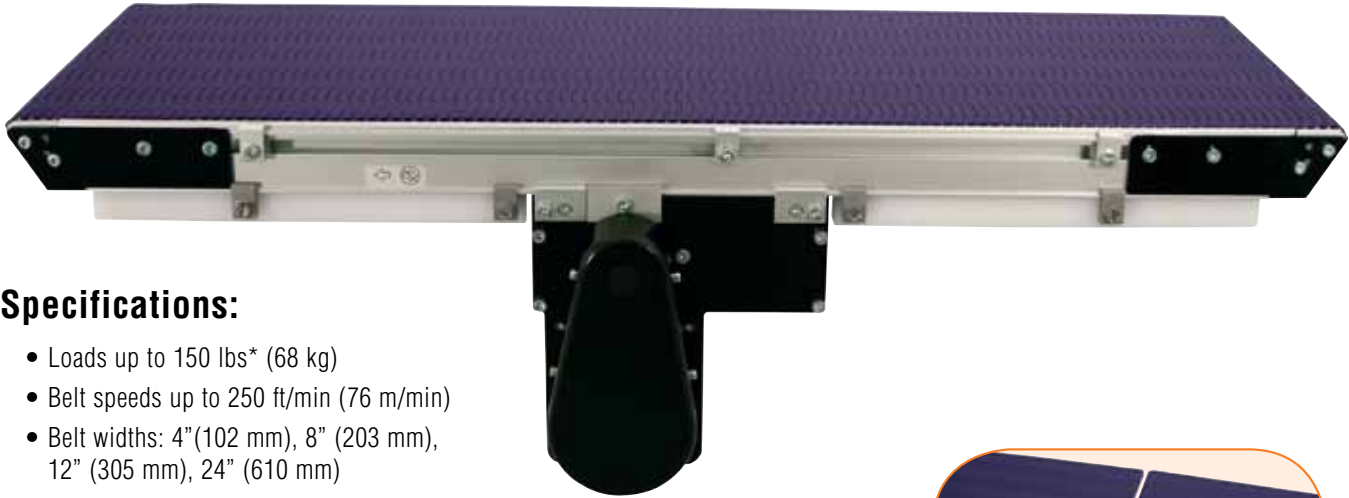

## Specifications:

- Loads up to 150 lbs\* (68 kg)
- Belt speeds up to 250 ft/min (76 m/min)
- Belt widths: 4" (102 mm), 8" (203 mm), 12" (305 mm), 24" (610 mm)
- Conveyor lengths: 32" (813 mm) to 30' (9,144 mm)
- 1.5" (38 mm) pitch diameter 15 tooth drive pulley turns approximately 4.7" (121 mm) of belt per revolution
- 0.33" (8 mm) micro pitch modular belt
- 12 mm diameter integral drive shaft
- Belt return system is full length UHMW support

\* Conveyor load capacity depends on conveyor size, incline, motor position, accumulated loads and other factors.



Belt Speed up to 175 ft/min (53.3 m/min).

## Features & Benefits:

- Center drive can be positioned along conveyor frame
- Center drive frees up both ends of conveyor for operator and machine interface
- 0.33" (8 mm) pitch modular belt for small part handling and smooth operation
- Modular belt features a flat belt surface ideal for inspection and label applications
- Sprocket driven belt and side guides provide worry free belt tracking
- Strong, box-like construction resists damaging frame twist
- T-Slots make mounting accessories simple with no drilling or special tools (2200)
- Stand mounting brackets are easily re-positioned along the T-Slot (2200)
- Smartslot® mounting system for attachments feature clean sides (2300)
- Sealed ball bearings

### Two Side Rail Options:

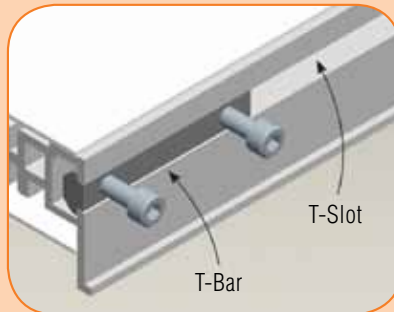

**2200 T-Slot Technology:**  
Drop in T-bar for ease and flexibility in mounting accessories

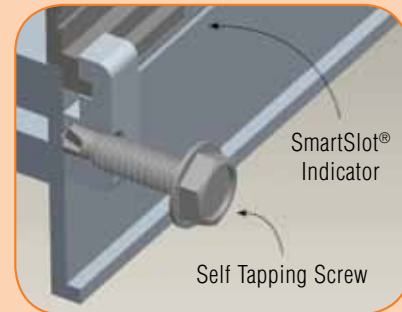

**2300 SmartSlot® Technology:**  
Functions like a T-Slot without collecting debris

*Order gearmotor mounting packages and gearmotors separately, see pages 40-61.  
For support stands and accessories, see pages 62-73.*

**For ordering information, see page 76**

**2200 & 2300 SERIES: MODULAR BELT CENTER DRIVE**

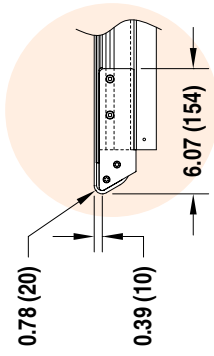
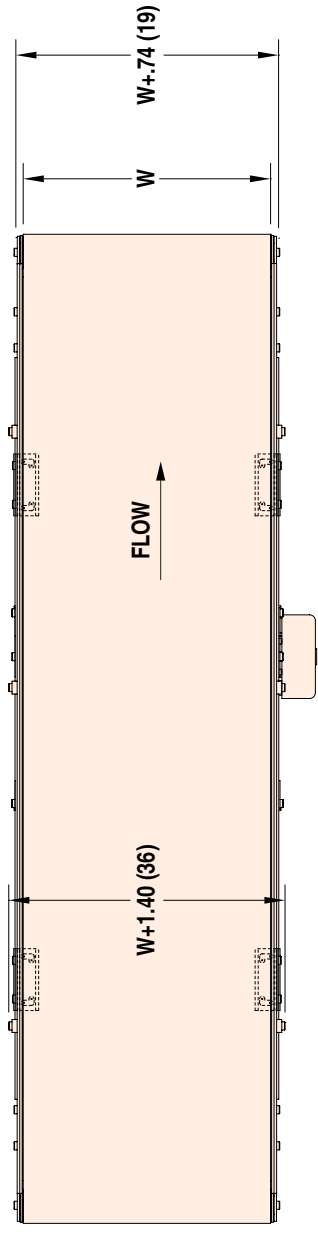

**OPTIONAL NOSE  
BAR TRANSFER**

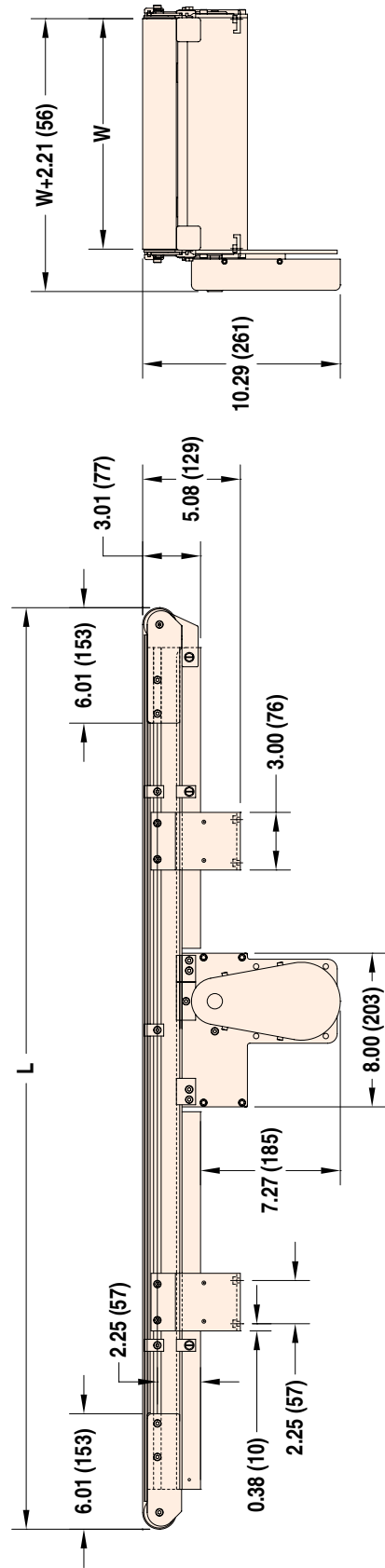

**W** = Conveyor Belt Width **Dim** = in (mm)

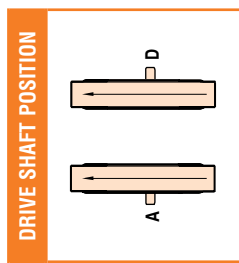

STANDARD SIZES				
Conveyor Width Reference	04	08	12	24
Conveyor Frame Width (W)	4.1" (104mm)	8.1" (206mm)	12.1" (307mm)	24.1" (612mm)
Conveyor Length Reference	0200	0001 increments up to...		3000
Conveyor Length (L)	2.67' (813mm)	0.1" (3mm) increments up to...		30' (9.144mm)

For more information, go to [www.dorner.com](http://www.dorner.com). Call 800.397.8664 or 262.367.7600.  
Due to the wide variety of drive set ups and applications, point of installation guarding is the responsibility of the end user.

# 2200 PRECISION MOVE: FLAT & CLEATED BELT END DRIVE



## Specifications:

- Loads up to 200 lbs\* (91 kg)
- Belt speeds up to 370 ft/min (113 m/min)
- Belt widths: 1.75" (44 mm) to 24" (610 mm)
- Conveyor lengths: 18" (457 mm) to 30' (9,144 mm)
- 1.5" (38 mm) pitch diameter drive pulley turns approximately 4.7" (121 mm) of belt per revolution
- T10 profile cogged belt with 12 tooth drive pulley
- Conveyor mechanical accuracy  $\pm 0.02$ "
- Conveyor package w/servo motor index accuracy  $\pm 0.04$ "
- 12 mm diameter integral drive shaft
- CE models available

\* Conveyor load capacity depends on conveyor size, incline, motor position, accumulated loads and other factors.



Positive Drive Belting



OPTIONAL:  
3 Cleat Heights Available

(20 mm, 36 mm, or 52 mm)

## Features & Benefits:

- High load capacity positive drive no slip belting
- Cogged belt and side guides provide worry free belt tracking
- No capacity drop when pushing belt
- Use optional cleats to create pockets for controlled part flow
- Rack and pinion belt tensioning for fast, accurate single-point belt tensioning
- T-slots make mounting accessories simple with no drilling or special tools
- Ability to drive multiple conveyors with Common and Slave Options
- Common drive conveyors run at exact same speed keeping wide parts in alignment
- Optional dual or idler end output shafts
- Slave driven conveyors can run at same speed or different speeds for gapping and pacing
- Compatible with standard drive packages
- Available with servo motor and mounts for increased accuracy of index
- Strong, box-like construction resists damaging frame twist
- Aluminum die cast head plates eliminate painted surfaces

### Common, Slave, and Servo Positioning Applications

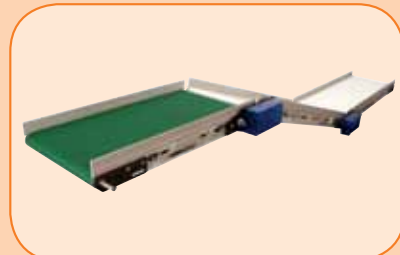

(see pages 30-33)

Order gearmotor mounting packages and gearmotors separately, see pages 40-61.  
For support stands and accessories, see pages 62-73.

For ordering information, see pages 77 and 78

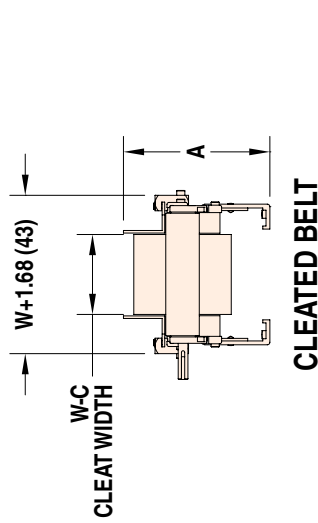

A = 6.10 (155) for 1" HIGH SIDES  
 7.10 (180) for 2" HIGH SIDES  
 C = 1.12 (29) for conveyors up to 8" widths  
 2.12 (54) for conveyors in 12" - 24" widths

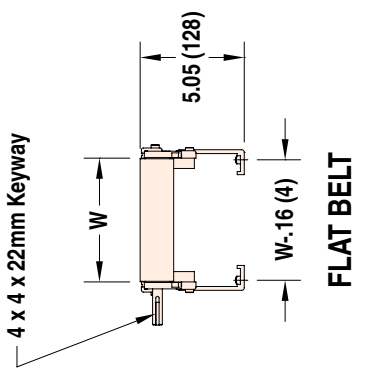

W = Conveyor Belt Width Dim = in (mm)

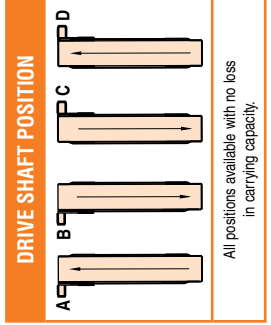
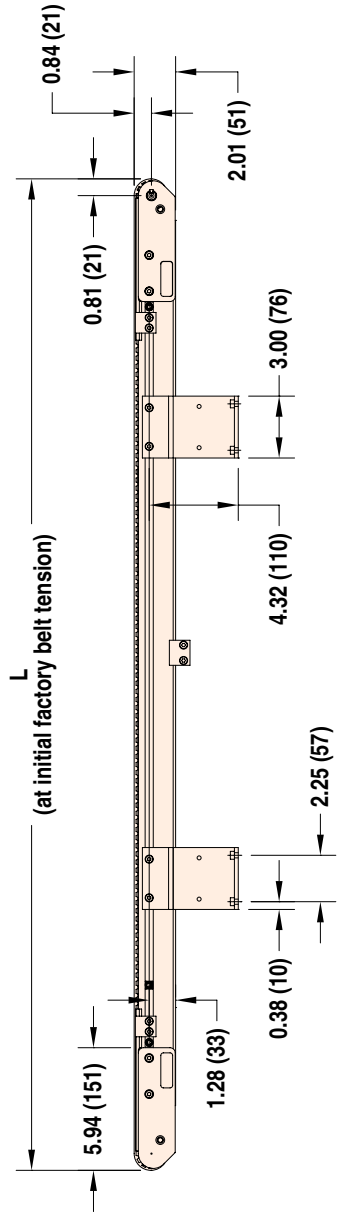
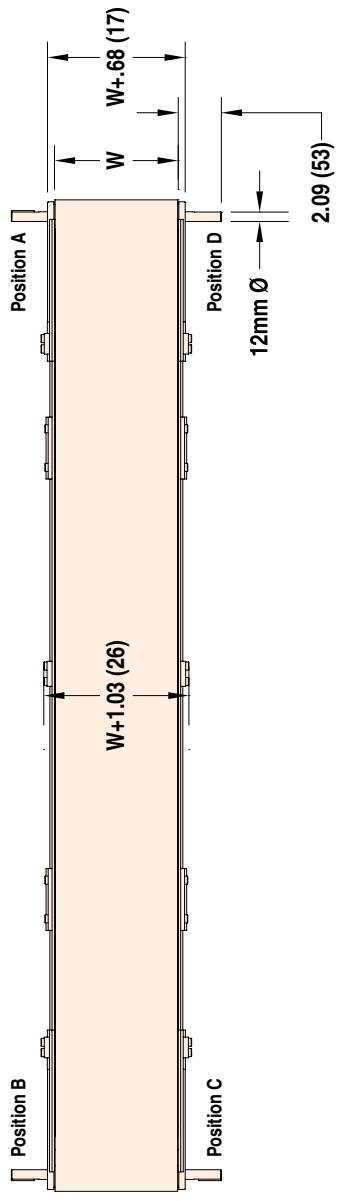

All positions available with no loss in carrying capacity.

STANDARD SIZES									
Conveyor Width Reference	02	03	04	06	08	12	18	24	
Conveyor Belt Width (W)	1.75" (45mm)	2.75" (70mm)	3.75" (95mm)	6.0" (152mm)	8.0" (203mm)	12.0" (305mm)	18.0" (457mm)	24.0" (607mm)	
Conveyor Length Reference	0150	0001 increments up to...							
Conveyor Length (L)	1.5' (457mm)	0.1" (2.54mm) increments up to...							

NOTE: Actual conveyor length may need to be adjusted to match belt pitch.

For more information, go to [www.dorner.com](http://www.dorner.com). Call 800.397.8664 or 262.367.7600.  
 Due to the wide variety of drive set ups and applications, point of installation guarding is the responsibility of the end user.

# 2200 & 2300 SERIES: FLAT BELT MID DRIVE



## Specifications:

- Loads up to 200 lbs\* (91 kg)
- Belt speeds up to 370 ft/min (113 m/min)
- Belt widths: 1.75" (44 mm) to 24" (610 mm)
- Conveyor lengths: 18" (457 mm) to 30' (9,144 mm)
- 2" (51 mm) pitch diameter drive pulley turns approximately 6.3" (160 mm) of belt per revolution
- T10 profile cogged belt with 16 tooth drive pulley
- Conveyor mechanical accuracy  $\pm 0.02$ "
- Drive shaft options
  - 12 mm diameter integral drive shaft
  - 16 tooth 0.5" diameter hollow spline drive
- CE models available

\* Conveyor load capacity depends on conveyor size, incline, motor position, accumulated loads and other factors.



## Features & Benefits:

- High load capacity positive drive no slip belting
- Cogged belt and side guides provide worry free belt tracking
- T-slots make mounting accessories simple with no drilling or special tools
- Mid mount can be positioned along conveyor frame
- Mid mount frees up both ends of conveyor for operator and machine interface
- Ability to drive multiple conveyors with Gang drive option
- Thru shaft available for gang drives (adjustable spacing)
- Gang drive conveyors run at exact same speed keeping wide parts in alignment
- Rack and pinion belt tensioning for fast, accurate single-point belt tensioning
- Available with standard bottom and side drive packages
- Strong, box-like construction resists damaging frame twist
- Aluminum die cast head plates eliminate painted surfaces

### Gang Drive with Adjustable Spacing



(see page 32)

Order gearmotor mounting packages and gearmotors separately, see pages 40-61.  
For support stands and accessories, see pages 62-73.

For ordering information, see page 78

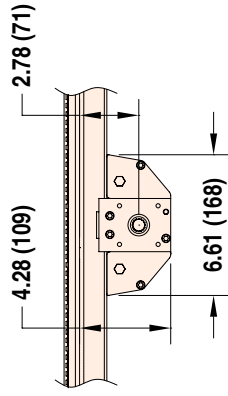

**16 TOOTH HOLLOW  
SHAFT SPLINE VERSION**

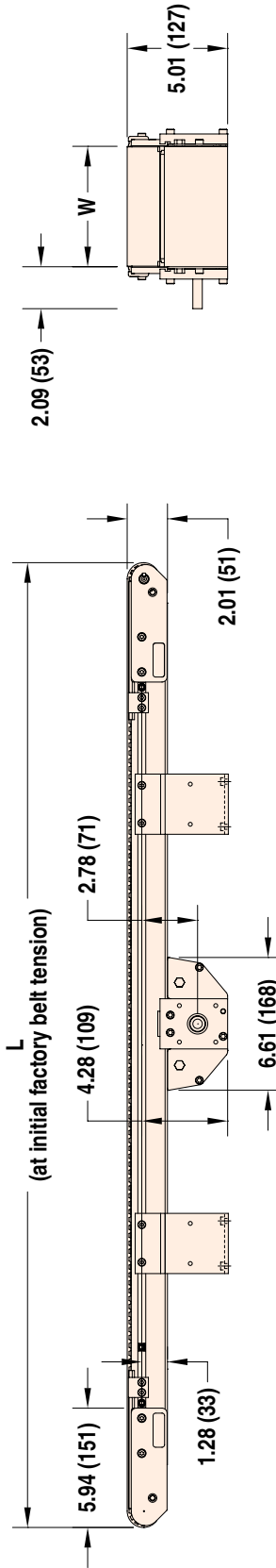
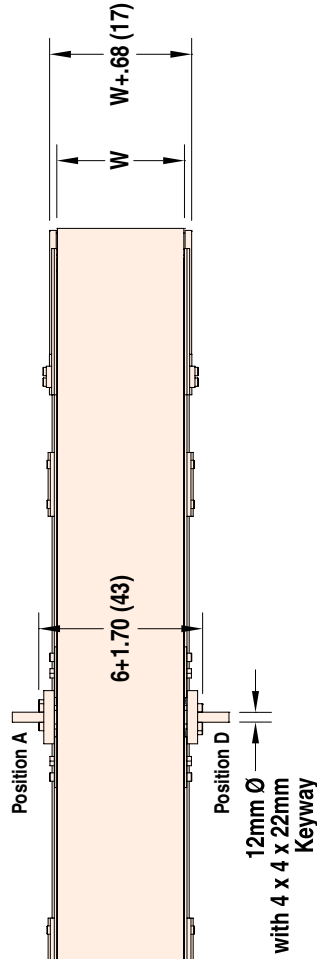

**W** = Conveyor Belt Width **Dim** = in (mm)

**STANDARD SIZES**

<b>Conveyor Width Reference</b>	02	03	04	06	08	12	18	24
<b>Conveyor Belt Width (W)</b>	1.75" (45mm)	2.75" (70mm)	3.75" (95mm)	6.0" (152mm)	8.0" (203mm)	12.0" (305mm)	18.0" (457mm)	24.0" (607mm)
<b>Conveyor Length Reference</b>	0150	0001 increments up to...						
<b>Conveyor Length (L)</b>	1.5' (457mm)	0.1" (2.54mm) increments up to...						

**NOTE:** Actual conveyor length may need to be adjusted to match belt pitch.

**DRIVE SHAFT POSITION**

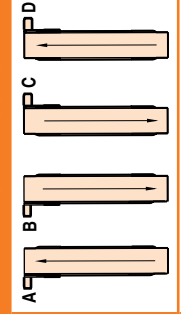

All positions available with no loss in carrying capacity.

# 2200 PRECISION MOVE: SLAVE DRIVE CONFIGURATIONS



## Slave Drive Configurations

### Features:

- Link multiple conveyors with 1 drive
- Adjustable angle from 0° to 25°
- Variety of timing belt ratios available
- 1:1, 1.27:1, 1.75:1, 2:1 can be used to speed or slow down the conveyor
- Pull or close gaps between product
- Change belt types on each conveyor
- Includes tie plates, pulley kit, tension adjustment and guard
- Maximum number of conveyors = 3

### Benefits:

- Save money by using less drives
- Flexibility to create your solution
- Utilize low, high friction belts, and/or multiple speeds in a single configuration

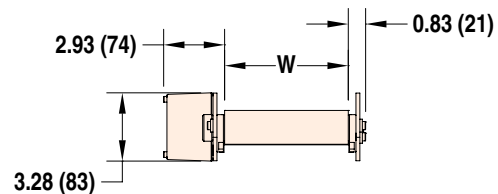
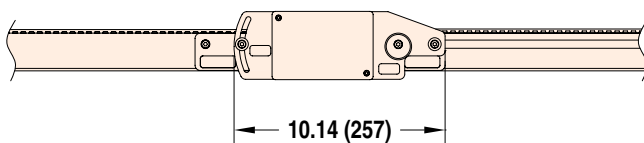
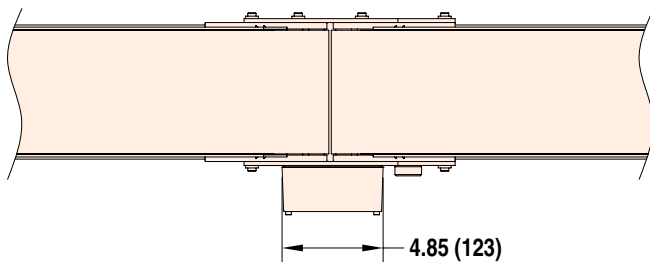

Part Number	Drive Teeth	Driven Teeth	Infeed Conveyor Speed Condition
202363-1632	16	32	2X Speed Up
202363-1628	16	28	1.75X Speed Up
202363-2228	22	28	1.27X Speed Up
202363-2222	22	22	Same Speed
202363-2822	28	22	0.78X Slow Down
202363-2816	28	16	0.57X Slow Down
202363-3216	32	16	2X Slow Down

**Note:** Not for cleated belt applications

### Kit Includes:

- Tie plates for both sides of conveyor
- Timing belt / pulleys and guard

*Due to the wide variety of drive set ups and applications, point of installation guarding is the responsibility of the end user.*



## Common Drive Kits

### Features:

- Exact speed match conveyors
- Cleats stay in time
- Parts can be wider than conveyor
- Conveyors can be different widths & lengths
- Minimum width (x) = 2.65" (67 mm) belt to belt
- Maximum width (y) = 48" (1,219 mm) belt to belt
- Maximum number of conveyors = 3
- Maximum total torque = 100 in-lbs
- Keyless coupling allows belt synchronization between conveyors
- Includes shafts, couplings and guards
- Conveyor tie kits ordered separately



**Common Drive (Fixed Width)**

### Benefits:

- Keeps parts from skewing
- Save money by using less drives

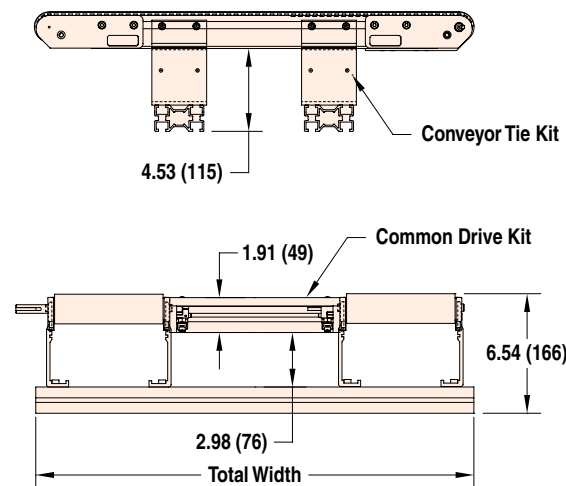
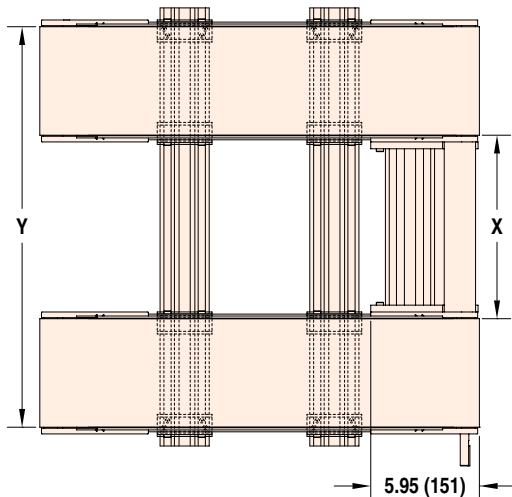

#### 2200 PRECISION MOVE: COMMON DRIVE KIT

202433 - GGGGG

Gap Between Belt Edges (X):  
00265 (2.65") to 04800 (48.00")

**Note:** One kit must be ordered for each pair of conveyors

#### Kit Includes:

- Shafts, couplings and guards
- Rigid tie plate for alignment

#### 2200 PRECISION MOVE: COMMON DRIVE TABLE MOUNT TIE KIT

39MCT -WW -Y

Number of Conveyors: 1 to 6  
Total Width: 02 to 48

#### Kit Includes:

- Conveyor mounting brackets
- Support extrusion





## Mid Drive Gang Driven Conveyors

### Features:

- Adjustable for various product widths
- Drive moveable between tails
- Frees up ends of conveyor
- Conveyor center distances can be moved while conveyor is running
- Minimum width (x) = 4" (101 mm) belt to belt (with std. guarding)
- Minimum width (x) = 1.75" (45 mm) belt to belt without guarding (end user responsible for point of installation guarding)
- Maximum width (y) = 48" (1,219 mm) belt to belt
- Maximum total torque = 80 in-lbs
- Compatible with side mount gearmotor package
- Requires ½" diameter 16 tooth spline drive shaft

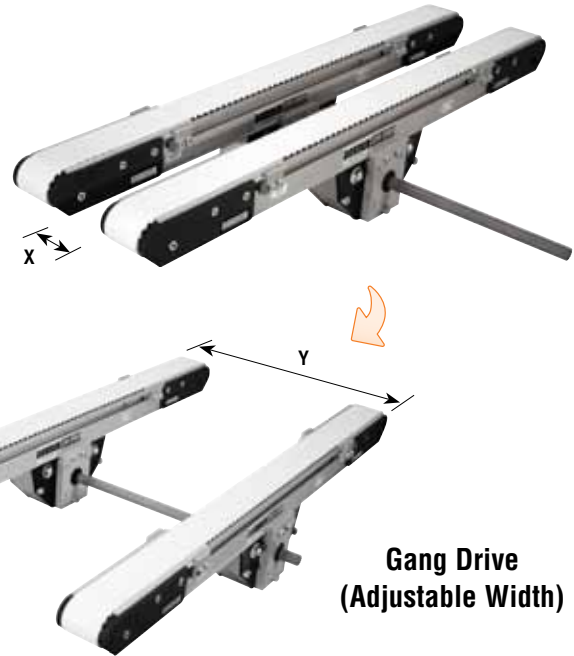

### Benefits:

- Flexibility to adjust to various product sizes
- Save money by using less drives
- Frees up ends of conveyors

## Gang Drive Side Mount Package

### Features:

- Compatible with all standard load and heavy load 90° gearmotors
- Conveyor position is adjustable along length of spline drive shaft
- Includes shafts, couplings, and expandable shaft guarding
- Mount package is attached to the first conveyor
- Maximum number of conveyors = 3
- Maximum total torque = 80 in-lbs



**Adjustable Position  
Conveyor Mount Available,  
CONTACT FACTORY**

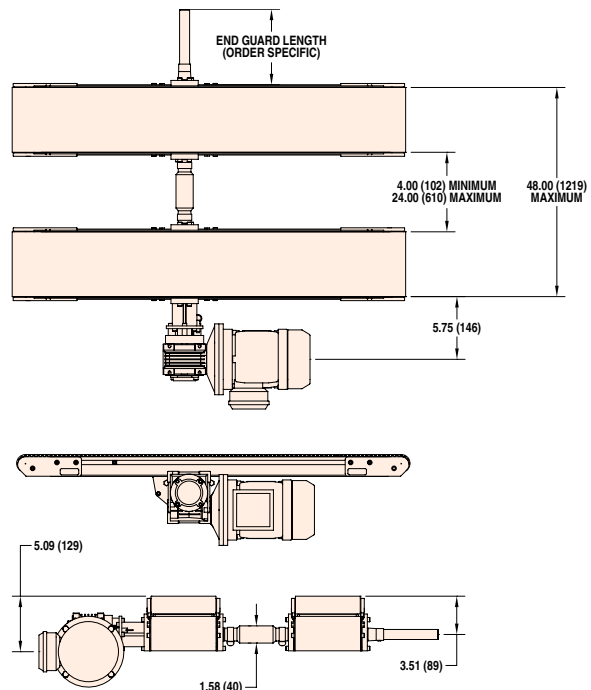

**Refer to page 49 for belt speed options.**

*Due to the wide variety of drive set ups and applications, point of installation guarding is the responsibility of the end user.*



## Precision Move Servo Gearmotor

### Features:

- Standard bottom and flush mount bottom drive configurations
- Indexes per minute rating = 100 per minute
- Conveyor/Drive Package Index accuracy =  $\pm 0.040$

### Motor:

- Kollmorgen AKM Series Motor
- Brushless DC Servomotor with encoder
- 80 mm Frame
- 1.02 kW
- Up to 640 VDC input
- Up to 2.62 amps
- Quick disconnect power and communication fittings
- UL, CE, RoHS Compliant

### Gearbox:

- Inline Planetary Reducer
- 4:1 Ratio
- 93% efficient
- 13 arc-minute backlash
- 20,000 hr rated
- RoHS compliant



Part Number	Controller Voltage	Max Belt Speed (Ft/min)		Min Belt Speed (Ft/min)	Torque (in-lb)	RPM
		Bottom Mount	Flush Mount			
22M004PR2B1KW	115V input	166	253	10	79	325
	230V input	276	420	10	79	625

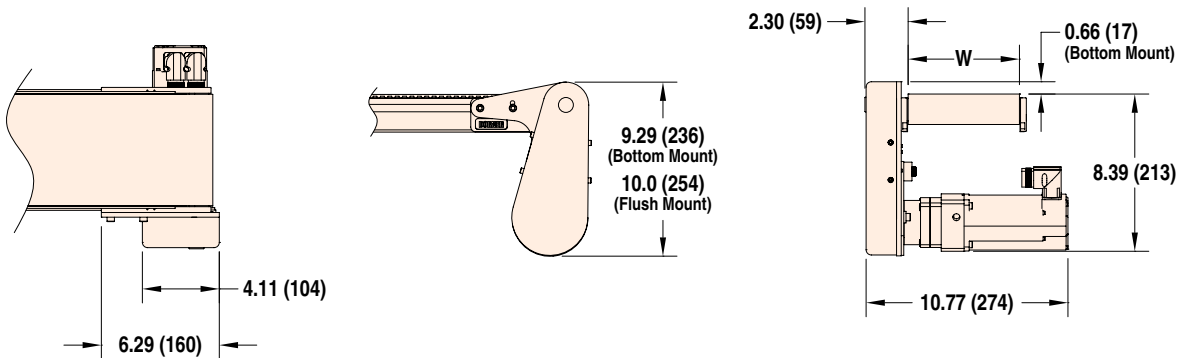

## Precision Move Servo Bottom and Flush Mount Package

### Features:

- Capable of standard bottom mount position and flush mount for wide product handling
- Includes rack and pinion timing belt tension system providing reversing capability
- Includes high strength timing belt drive pulleys

Description	Motor / Gearhead	Part Number	Gearmotor Pulley	Conveyor Pulley
Bottom Mount	Servo Gearmotor	202436-A*	36 tooth	32 tooth
Flush Mount	Servo Gearmotor	202437-A*	36 tooth	21 tooth
Bottom Mount	Nema 34 Gearhead	202436-A*	36 tooth	32 tooth
Flush Mount	Nema 34 Gearhead	202437-A*	36 tooth	21 tooth

\*A = Mount position (A, B, C, D)



Due to the wide variety of drive set ups and applications, point of installation guarding is the responsibility of the end user.

## Precision Move Servo Gearhead Only



Part Number	Effective Reduction Ratio		Conveyor Speed Multiply Factor	
	Bottom Mount	Flush Mount	Bottom Mount	Flush Mount
22M004PRN34	3.556 : 1	2.333 : 1	(Motor RPM) (0.111)	(Motor RPM) (0.169)

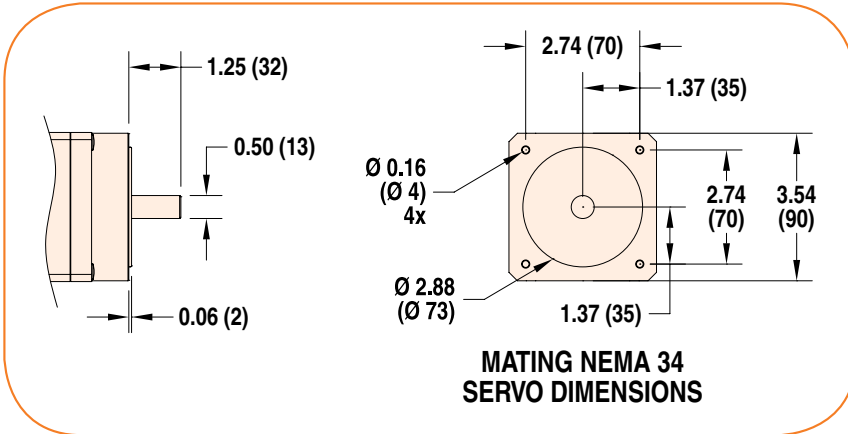

### Features:

- Offered as mount package and gearhead only
- Standard Nema 34 input mounting dimensions
- Inline planetary reducer
- 4:1 ratio
- 93% efficient
- 13 arc-minute backlash
- 20,000 hr rated
- RoHS compliant

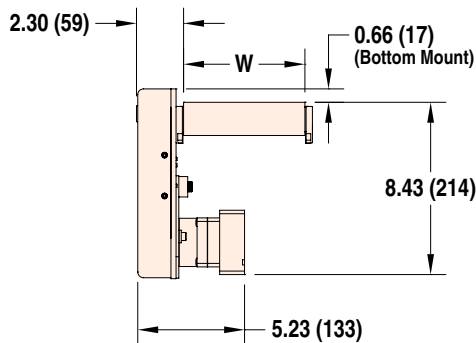
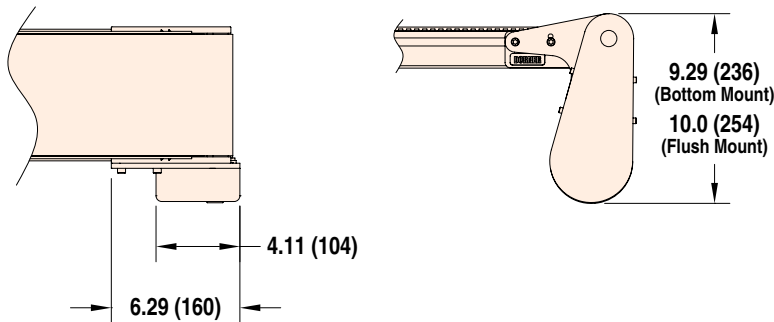

# 2200 & 2300 SERIES: PROFILES

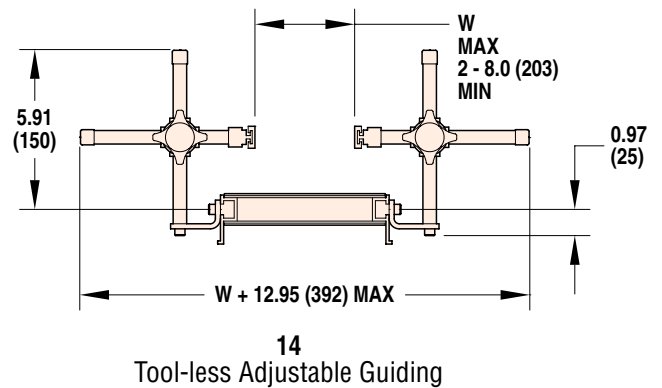
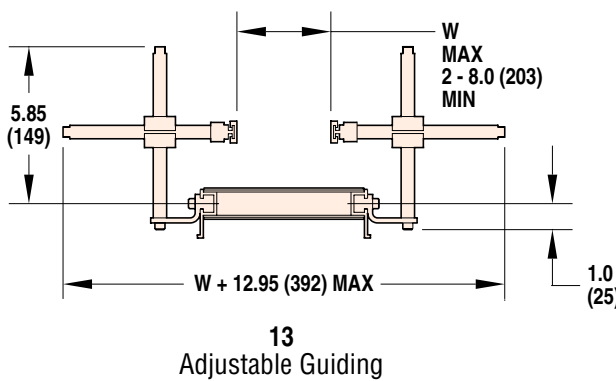
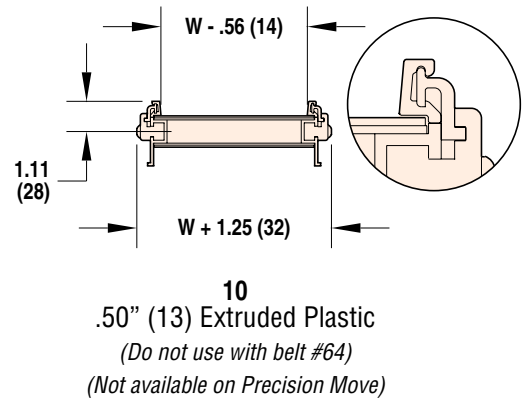
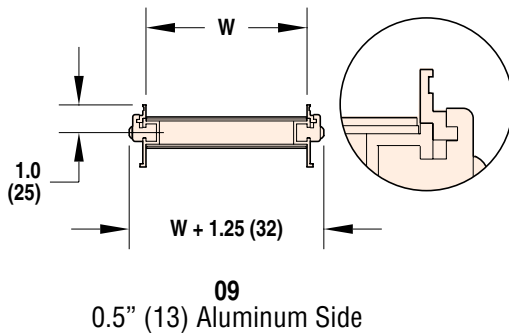
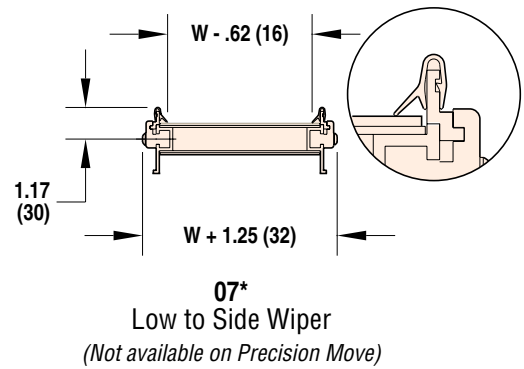
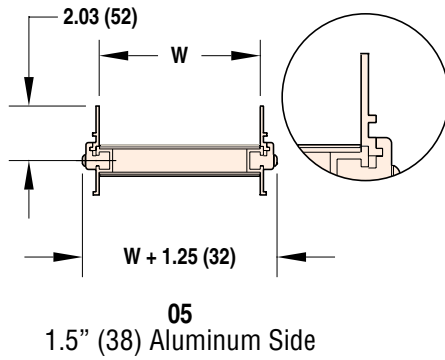
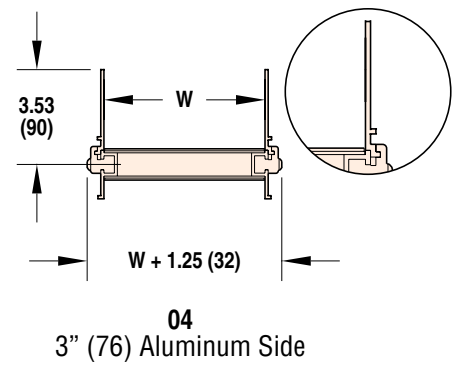
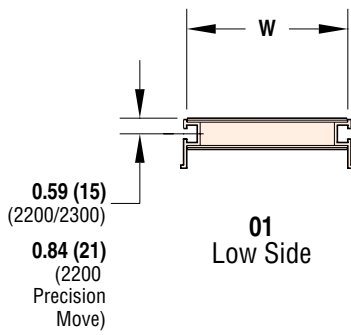

\* = Not available on Gravity Roller Conveyors and do not use with high friction belts

W = Conveyor Belt Width Dim = in (mm)

Due to the wide variety of drive set ups and applications, point of installation guarding is the responsibility of the end user.

# 2200 & 2300 SERIES: MODULAR BELT PROFILES

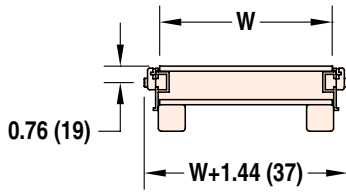

**01**  
Low Side

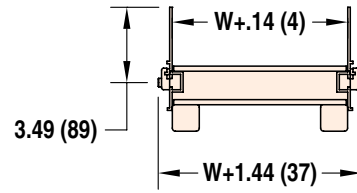

**04**  
3" (76) High Side

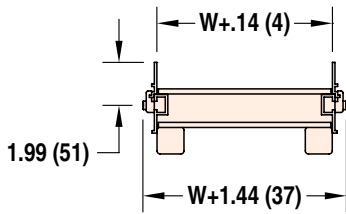

**05**  
1.5" (38) High Side

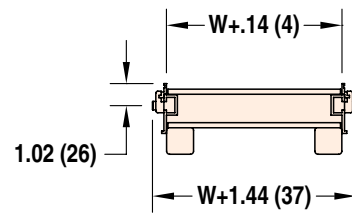

**09**  
0.5" (13) High Side

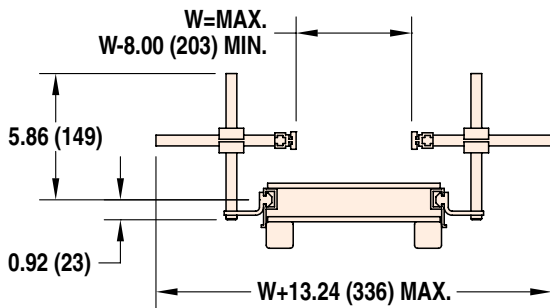

**13**  
Adjustable Guiding

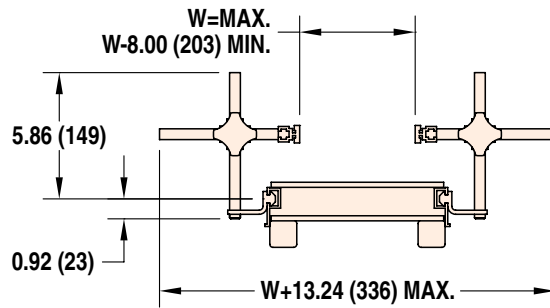

**14**  
Tool-less Adjustable Guiding

W = Conveyor Belt Width Dim = in (mm)

# 2200 & 2300 SERIES: STANDARD BELTING



## Standard Belt Selection Guide

Standard belt material is stocked at Dorner, then cut and spliced at the factory for fast conveyor shipment.

Belt Type - Finger Splice	Belt Type - Plastic Clipper	Belt Type - Metal Clipper	Belt Specifications	Thickness	Surface Material	Carcass Material	Maximum Part Temperature	Coefficient of Friction	FDA Approved	Anti-Static	Static Conductive	Chemical Resistance	Special Characteristics or Applications
01	A1	1A	FDA Accumulation	0.067 (1.7)	Urethane	Polyester	212°F (100°C)	Low	x	x		Good	Packaging, clean room & inspection
02	A2	2A	General Purpose	0.071 (1.8)	Urethane	Polyester	212°F (100°C)	Med	x	x		Good	Most versatile belt offering
03	A3	3A	FDA High Friction	0.067 (1.7)	Urethane	Polyester	212°F (100°C)	High	x	x		Good	Packaging, clean room & inspection
05	A5	5A	Accumulation	0.047 (1.2)	Urethane	Polyester	212°F (100°C)	V-Low	x	x		Good	Accumulation of products
06	A6	6A	Electrically Conductive	0.063 (1.6)	Urethane	Polyester	176°F (80°C)	Low		x	x	Good	Electronics Handling
08	A8	8A	High Friction	0.083 (2.1)	PVC	Polyester	158°F (70°C)	V-High		x		Poor	Conveys up to 35° inclines*
09			iDrive General Purpose	0.055 (1.4)	Urethane	Polyester	212°F (100°C)	High	x			Good	Lower No Load Torque

Dim = in (mm)

**Note:** See below for splice details. Plastic Clipper splice requires longer lead times.

**Note:** Belts with V-guiding may have a slight high spot or rib on the top surface. This rib would run longitudinally along the center of the belt. Consult factory with applications for which this may cause interference.

\* Incline varies due to factors like dust, fluids and part material.

## BELT SPLICING



### Finger Splice

All belts are available with a standard Thermoformed finger splice. This splice makes the belt continuous and is virtually undetectable. Splice bonding methods vary by belt type. Consult factory for details.



### Plastic Clipper\*\*

An optional plastic clipper splice is available for quick removal of belts or when conveyors are installed in tight spaces.

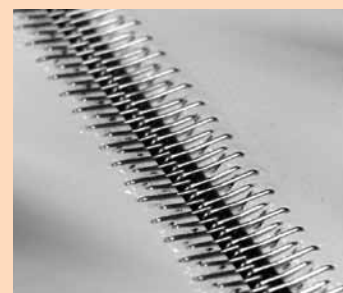

### Metal Clipper\*\*

An optional metal clipper splice is also available for quick removal of belts or when conveyors are installed in tight spaces.

\*\* See belt charts for compatibility. Not for use with 2200/2300 Series Nose Bar Transfer or 2200/2300 Series with bottom wiper option. Plastic and Metal Clippers are slightly thicker than base belt. Contact factory for details.

# 2200 & 2300 SERIES: SPECIALTY BELTING



## Specialty Belt Selection Guide

Specialty belt material is not stocked at Dorner and needs to be custom ordered for your special conveyor needs.

Belt Type - Finger Splice	Belt Type - Plastic Clipper	Belt Type - Metal Clipper	Belt Specifications	V-guided	Belt Thickness	Surface Material	Maximum Part Temperature	Coefficient of Friction	FDA Approved	Chemical Resistance	Special Characteristics or Applications
19			Nose Bar, High Friction		0.02 (0.6)	Urethane	212°F (100°C)	High	x	Good	Very Small Product Transfer
50			Heat Resistant		0.05 (1.3)	Silicone	356°F (180°C)	Low		Good	
53			Translucent & Nose Bar, Accumulation		0.02 (0.5)	Urethane	212°F (100°C)	V-Low	x	Good	Back Lit inspection & Very Small Product Transfer
54	F4	4F	FDA Sealed Edge**	x	0.06 (1.6)	Urethane	176°F (80°C)	Low	x	Good	Packaging, clean room & inspection
55	F5	5F	FDA Sealed Edge**	x	0.06 (1.6)	Urethane	176°F (80°C)	High	x	Good	Packaging, clean room & inspection
56		6F	Cut Resistant	x	0.08 (2.1)	Urethane	212°F (100°C)	Med		Good	Oily product release, Metal stamping
57		7F	Cut Resistant*	x	0.10 (2.5)	Nitrile	176°F (80°C)	Med		Poor	Felt-like, dry metal stamping, glass & ceramic
58		8F	Cut Resistant		0.06 (1.5)	Urethane	176°F (80°C)	Low		V-Good	Cross-linked surface, Gold colored
59	F9	9F	Color Contrasting	x	0.06 (1.5)	PVC	158°F (70°C)	Med		Poor	Black colored, hides overspray from ink jet
60	G0	0G	Color Contrasting	x	0.05 (1.3)	Urethane	212°F (100°C)	Low	x	Good	Green colored
61	G1	1G	Color Contrasting	x	0.05 (1.3)	Urethane	212°F (100°C)	Low	x	Good	Blue colored
63		3G	Electrically Conductive	x	0.05 (1.2)	Urethane	176°F (80°C)	Low		Good	Static conductive, electronics handling
64		4G	High Friction	x	0.17 (4.4)	PVC	194°F (90°C)	V-High		Poor	Dark Green colored, rough top surface, product cushioning, incline / decline apps
66		6G	Chemical Resistant	x	0.07 (1.7)	Polyester	212°F (100°C)	Med	x	V-Good	Good Cut resistance, metal stamping apps
67		7G	Low Friction Cleated	x	0.06 (1.6)	Polyester	212°F (100°C)	n/a	x	Good	Excellent product release, consult factory for part number and how to specify low friction
68	G8		FDA Encased**	x	0.06 (1.5)	Urethane	176°F (80°C)	Low	x	Good	Urethane enclosed for added sanitary protection
69	G9		FDA Encased**	x	0.09 (2.2)	Urethane	212°F (100°C)	Med	x	Good	Urethane enclosed for added sanitary protection

Dim = in (mm)

**Note:** Plastic Clipper splice requires longer lead times.

**Note:** Belts with V-guiding may have a slight high spot or rib on the top surface. This rib would run longitudinally along the center of the belt.

Consult factory with applications for which this may cause interference.

\* 12" (305 mm) wide conveyor maximum for non V-guided

\*\* Not available on 1.75" (44 mm) wide conveyors.

# 2200 & 2300 SERIES: STANDARD BELTS & CLEATS

## 2200 & 2300 MODULAR BELT

### Modular Belt Selection Guide

Belt Type	Description	Tooth Pitch	Thickness	Material	Color	Maximum Part Temperature	Coefficient of Friction	FDA Approved	Chemical Resistance
01	Accumulation, Closed Mesh	0.33 (8.4)	0.236 (6)	Acetal	Blue	200°F (93°C)	Low	x	Good

**Note:** White belt is available, contact factory for details. Dim = in (mm)

## 2200 PRECISION MOVE STANDARD BELTS & CLEATS

### Standard Belt Selection Guide

*Standard belt material is stocked at Dorner, then cut and spliced at the factory for fast conveyor shipment.*

Belt Type - Finger Splice	Belt Specifications	Tooth Pitch	Thickness	Material	Top Surface	Color	Maximum Part Temperature	Coefficient of Friction	Durometer	FDA Approved	Chemical Resistance	Max Width
1P	Low Friction	10 mm	0.175 (4.5)	Urethane with nylon top	Carcass	Green	195°F (91°C)	Low	N/A		Good	24 (610)
3P	High Friction	10 mm	0.175 (4.5)	Urethane	Smooth	White	195°F (91°C)	High	85A	x	Good	24 (610)
2T	High Strength	10 mm	0.180 (4.6)	Urethane with Stainless cords	Smooth	Clear	160°F (71°C)	Med	92A		Good	6 (152)

Dim = in (mm)

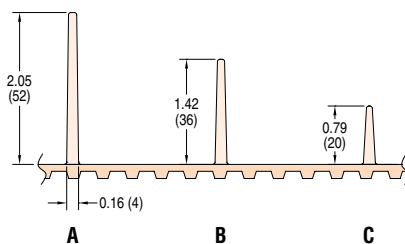

**Base Belt Material:** Belt 3P, 0.175" (4.5 mm) thick, high friction FDA approved urethane, 195°F (91°C) maximum part temperature. Cleat spacing in 10 mm increments. Cleats located centered over tooth.

**Note:** Minimum cleat spacing is approximately 1.57" (40 mm). Consult Factory.

## STANDARD CLEATS

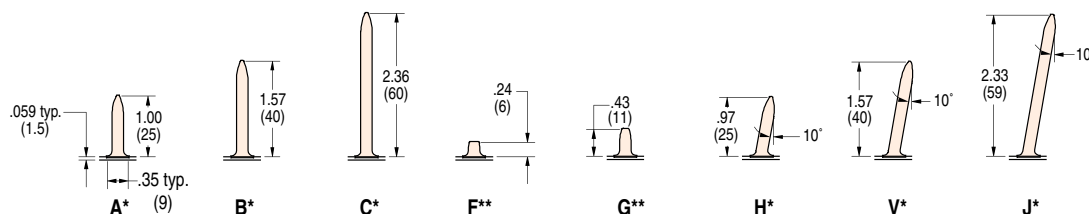

- \* Maximum 20" (508 mm) cleat spacing for 18" and wider conveyors with lengths greater than 7' (2,134 mm)
- \*\* 18" and wider conveyors have a maximum length of 7' (2,134 mm)

**Base Belt Material:** 0.059" (1.5 mm) thick, high friction FDA approved urethane, 176°F (80°C) maximum part temperature. See Specialty Belt 67 for low friction base belt material.

**Note:** Minimum cleat spacing is approximately 2" (51 mm). Consult Factory.



# 2200 & 2300 SERIES: GEARMOTOR MOUNTING PACKAGES

## GEARMOTOR MOUNTING PACKAGE & GEARMOTOR SELECTION STEPS

- Step 1:** Select a **Gearmotor Mounting Package**. For End drive conveyors, select a side, bottom, top, flush or bolster drive mount (pages 41-49). If a Center Drive or Mid Drive conveyor is being outfitted, refer to the Center Drive section on pages 50-52. Be sure to note if it is for a **90°** or **Parallel Shaft Gearmotor**.
- Step 2:** Using **Belt Speed and Load** Requirements, determine the required **Gearmotor Type** (Light, Heavy or Standard) for your application using the chart below.
- Step 3:** Find the appropriate set of Belt Speed Charts (pages 43, 44, 46, 47, 49, 51 and 52) for the Mounting Package you selected and choose between the **Fixed** or **Variable Speed** chart.
- Step 4:** Go down the first column of the Belt Speed Chart and locate the required **Belt Speed** for your application. If the desired belt speed is not listed, round up to the next higher speed.  
(Dorner offers much more than just the belt speeds listed in the tables, contact the factory for complete details)
- Step 5:** From the row containing your required **Belt Speed**, check to be sure that speed is available for the **Mount Package** you chose. (End Drive Only - Top, Bottom or Side)
- Step 6:** Use the Drive / Driven Pulley Kit combination to complete your Mounting Package Part Number
- Step 7:** Note the **RPM from Gearmotor**, it will be needed to select the correct Gearmotor from the Gearmotor Chart.
- Step 8:** Reference the **Gearmotor Chart #** to locate a compatible Gearmotor Chart on pages 53-59. Be sure to select a Gearmotor Chart to match your **Gearmotor Type** (Light, Standard or Heavy) and your **Mounting Package** while meeting your electrical requirements.  
(Red = Parallel Shaft or Blue = 90°)
- Step 9:** Using the **RPM from Gearmotor** (Step 6), locate the **Part Number** for your Gearmotor from the Gearmotor Table.

GEARMOTOR TYPE		Conveyor Load - Lbs (Kg)											
		10 (4.5)	20 (9.1)	30 (13.6)	40 (18.2)	50 (22.7)	60 (27.3)	70 (31.8)	80 (36.4)	90 (40.9)	100 (45.5)	110 (50)	120 (54.5)
Belt Speed - Ft/min (m/min)	0-15 (0-4.6)												
	16-30 (4.9-9.1)												
	31-45 (9.5-13.7)												
	46-60 (14-18.3)												
	61-75 (18.6-22.9)												
	76-90 (23.2-27.4)												
	91-110 (27.7-33.5)												
	111-130 (33.8-39.6)												
	131-150 (39.9-45.7)												
	151-175 (46-53.4)												
	176-200 (53.7-61)												
	201-225 (61.3-68.6)												
	226-250 (68.9-76.2)												
251-275 (76.5-83.8)													

Gearmotor Mounting Package Selection Guide		APPLICATION										
		Wet Products / Environments	3" (76) and taller products	Manual / Automated Assembly	Table top mounting	Tight machine interface	Aesthetics	Driving multiple conveyors	Clearance at discharge	Operator Ergonomics	Test and Inspect	Metal Forming
MOUNT PACKAGE	Side Mount Package	X	X		X				X			
	Top Mount Package	X			X				X			
	Bottom Mount Package		X	X			X		X	X		
	Center Drive Conveyor					X			X	X		
	Flush Mount								X	X		
	Bolster Mount Package							X				X
	Common Drive Package							X				

# 2200 & 2300 SERIES: END DRIVE MOUNTING PACKAGES

## Side Mount Package, 90° Gearmotor

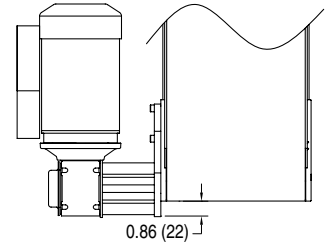
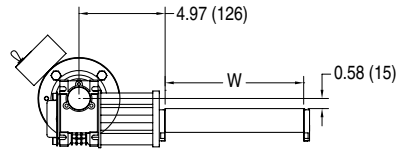

- Includes gearmotor mounting bracket, coupling, coupling guard and mounting hardware

W = Conveyor Belt Width

## Bottom Mount Package, 90° Gearmotor

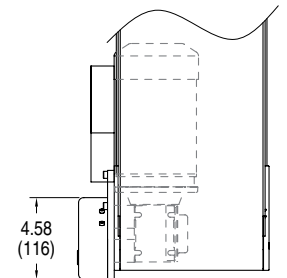
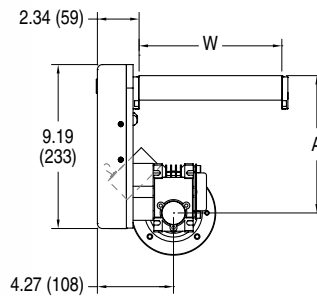

A: Standard Load Flat Belt = 5.33 (135)  
Standard Load Cleated Belt = 7.70 (195)

- Includes gearmotor mounting bracket, timing belt and pulleys, guard cover and mounting hardware

W = Conveyor Belt Width

## Top Mount Package, 90° Gearmotor

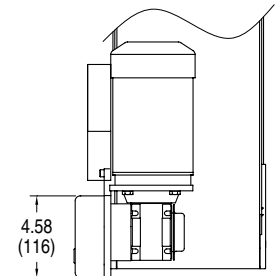
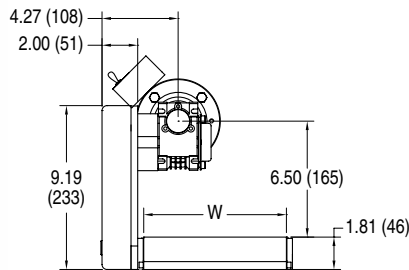

- Includes gearmotor mounting bracket, timing belt and pulleys, guard cover and mounting hardware

W = Conveyor Belt Width

## 90° Standard Load Gearmotor Location Options

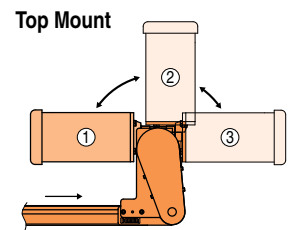
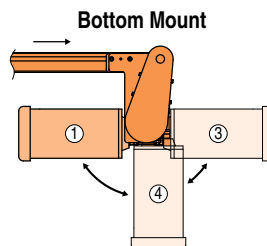
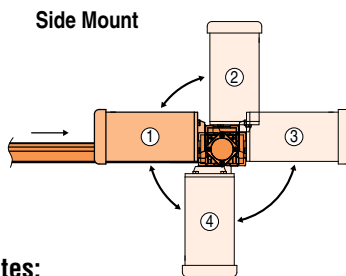

### Notes:

- Position 1 recommended
- Vertical positions 2 and 4 may require additional stabilizing bracket

Consult factory for details

Note: Conveyor and gearmotor are not included in the mounting package and must be ordered separately. Dimensions = in (mm)

For ordering information, see page 79

# 2200 & 2300 SERIES: END DRIVE MOUNTING PACKAGES

## Side Mount Package, Parallel Shaft Gearmotor

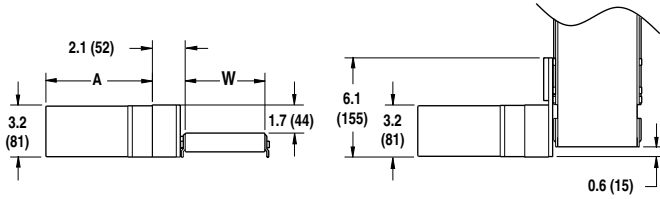

<b>A:</b>	Light Load, Fixed Speed and VFD Variable Speed	= 4.6 (117)
	Light Load, DC Variable	= 6.7 (170)
	Light Load CE Fixed Speed	= 7.2 (183)



### Light load gearmotors only

- Includes gearmotor mounting bracket, coupling, coupling guard and mounting hardware

W = Conveyor Belt Width

## Bottom Mount Package, Parallel Shaft Gearmotor

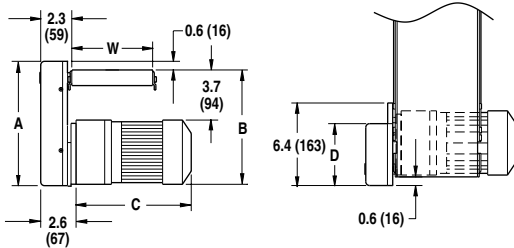

<b>A:</b>	Light Load Flat Belt	= 6.9 (175)	<b>C:</b>	Light Load, Fixed Speed and VFD Variable Speed	= 4.6 (117)
	Light Load Cleated Belt	= 8.9 (226)		Light Load, DC Variable Speed	= 6.7 (170)
	Standard Load Flat Belt	= 9.2 (234)		Standard Load	= 10.5 (267)
	Standard Load Cleated Belt	= 9.2 (234)	<b>D:</b>	Light Load Flat Belt	= 6.1 (155)
<b>B:</b>	Light Load Flat Belt	= 6.2 (158)		Light Load Cleated Belt	= 5.6 (142)
	Light Load Cleated Belt	= 8.3 (211)		Standard Load Flat Belt	= 4.6 (116)
	Standard Load Flat Belt	= 8.5 (216)		Standard Load Cleated Belt	= 4.6 (116)
	Standard Load Cleated Belt	= 10.3 (262)			



- Includes gearmotor mounting bracket, timing belt and pulleys, guard cover and mounting hardware

W = Conveyor Belt Width

## Top Mount Package, Parallel Shaft Gearmotor

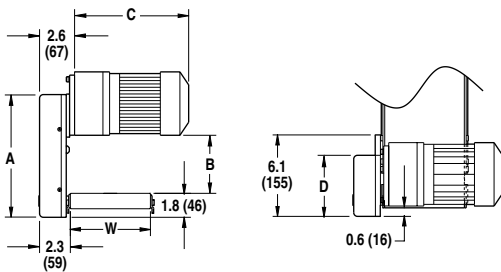

<b>A:</b>	Light Load	= 8.9 (226)	<b>C:</b>	Light Load, Fixed Speed and VFD Variable Speed	= 4.6 (117)
	Standard Load	= 9.2 (234)		Light Load, DC Variable Speed	= 6.7 (170)
				Standard Load	= 10.5 (267)
<b>B:</b>	Light Load	= 3.3 (84)	<b>D:</b>	Light Load	= 5.6 (142)
	Standard Load	= 4.3 (110)		Standard Load	= 4.6 (116)



- Includes gearmotor mounting bracket, timing belt and pulleys, guard cover and mounting hardware

W = Conveyor Belt Width

Note: Conveyor and gearmotor are not included in the mounting package and must be ordered separately. Dimensions = in (mm)

For ordering information, see page 79

# 2200 & 2300 SERIES: END DRIVE BELT SPEED CHARTS

Refer to the Gearmotor Selection Steps on page 40 for instructions on using the Belt Speed Charts.

Fixed Speed													
2200 / 2300		2200 Precision Move		2200 / 2300 Modular Belt		RPM From Gearmotor	Mount Package		Pulley Kit		Gearmotor Chart #		
Ft/min	m/min	Ft/min	m/min	Ft/min	m/min		Top & Bottom	Side	Drive Pulley	Driven Pulley	Light Load	Std. Load	Heavy Load
2	0.6	2.3	0.7	2.3	0.7	10	x		22	32		5	
3	0.9	3.5	1.1	3.5	1.1	10	x		28	28		5	
5	1.5	5.8	1.8	5.8	1.8	10	x		44	22		5	
6	1.8	6.9	2.1	7.0	2.1	29	x		19	32		4	12, 13
10	3.1	12	3.5	12	3.5	29	x	x	28	28		4, 5	12, 13
13	4.0	15	4.6	15	4.6	42	x		28	32	1		
15	4.6	17	5.3	17	5.3	42	x	x	28	28	1		
15	4.6	17	5.3	17	5.3	43	x	x	28	28		4, 19	12, 13
16	4.9	18	5.6	19	5.7	29	x		44	28		4, 5	12, 13
21	6.4	24	7.4	24	7.4	42	x		32	22	1		
24	7.3	28	8.4	28	8.5	43	x		44	28		4	12, 13
29	8.8	33	10.2	34	10.3	42	x		44	22	1		
30	9.2	35	10.5	35	10.6	86	x	x	28	28		4, 5	12, 13
35	10.7	40	12.3	41	12.4	100	x	x	28	28	1	19	
48	14.6	55	16.8	56	17.0	86	x		44	28		4, 5	12, 13
55	16.8	63	19.3	64	19.5	100	x		44	28	1		
61	18.6	70	21.4	71	21.6	173	x	x	28	28		4, 5	12, 13
95	29.0	109	33.3	110	33.6	173	x		44	28		4, 5	12, 13
104	31.7	120	36.5	121	36.8	173	x		48	28		4, 5	12, 13
121	36.9	139	42.4	140	42.8	345	x	x	28	28		4, 5	12, 13
138	42.1	159	48.4	160	48.8	345	x		32	28		4, 5	12, 13
176	53.7	202	61.7	204	62.3	345	x		32	22		4, 5	12, 13
208	63.4	239	73.0	241	73.6	345	x		48	28		4, 5	12, 13
242	73.8	278	84.9			345	x		44	22		4, 5	12, 13
264	80.5	304	92.6			345	x		48	22		4, 5	12, 13
CE Gearmotor RPM at 50 Hz													
5	1.5	5.8	1.8	5.8	1.8	23*	x		19	32		6	
8	2.4	9.2	2.8	9.3	2.8	23*	x	x	28	28		6	
12	3.7	13.8	4.2	13.9	4.2	35*	x	x	28	28		6	
19	5.8	22	6.7	22	6.7	35*	x		44	28			
21	6.4	24	7.4	24	7.4	41*	x		32	22	2		
25	7.6	29	8.8	29	8.8	70*	x	x	28	28		6	
39	11.9	45	13.7	45	13.8	70*	x		44	28		6	
49	14.9	56	17.2	57	17.3	140*	x	x	28	28		6	
50	15.3	58	17.5	58	17.7	144*	x	x	28	28	2		
77	23.5	89	27.0	89	27.2	140*	x		44	28		6	
96	29.3	110	33.7	111	34.0	280*	x	x	28	28		6	
112	34.2	129	39.3	130	39.6	280*	x		32	28		6	
143	43.6	164	50.2	166	50.6	280*	x		32	22		6	
169	51.5	194	59.3	196	59.8	280*	x		48	28		6	
197	60.1	227	69.1	229	69.7	280*	x		44	22		6	
214	65.3	246	75.1	248	75.7	280*	x		48	22		6	
268	81.7	308	94.0			280*	x		60	22		6	

Note: Nose Bar transfers operate at maximum 77 ft/min (23.5 m/min) belt speed Red = Parallel Shaft, Blue = 90°

# 2200 & 2300 SERIES: END DRIVE BELT SPEED CHARTS

Refer to the Gearmotor Selection Steps on page 40 for instructions on using the Belt Speed Charts.

Variable Speed													
2200 / 2300		2200 Precision Move		2200 / 2300 Modular Belt		RPM From Gearmotor	Mount Package		Pulley Kit		Gearmotor Chart #		
Ft/min	m/min	Ft/min	m/min	Ft/min	m/min		Top & Bottom	Side	Drive Pulley	Driven Pulley	Light Load	Std. Load	Heavy Load
0.4 - 3.4	0.1 - 1	0.5 - 3.9	0.1 - 1.2	0.5 - 3.9	0.1 - 1.2	14	x		22	32		10	
0.6 - 5	0.2 - 1.5	0.7 - 5.8	0.2 - 1.8	0.7 - 5.8	0.2 - 1.8	14	x		28	28		10	
0.6 - 6	0.2 - 1.8	0.7 - 6.9	0.2 - 2.1	0.7 - 7	0.2 - 2.1	29	x		19	32		8	15, 16
1 - 10	0.3 - 3.1	1.2 - 11.5	0.4 - 3.5	1.2 - 11.6	0.4 - 3.5	29	x		28	28		8, 11	15, 16
1.8 - 14	0.5 - 4.3	2 - 16	0.6 - 4.9	2.1 - 16	0.6 - 5	42	x	x	28	28	3	7, 10, 20	14
1.5 - 15	0.5 - 4.6	2 - 17	0.5 - 5.3	1.7 - 17	0.5 - 5.3	43	x		28	28		9	15, 16
2.6 - 22	0.8 - 6.7	3 - 25	0.9 - 7.7	3 - 26	0.9 - 7.8	63	x	x	28	28		8	14
2.8 - 23	0.9 - 7	3 - 26	1 - 8	3.2 - 27	1 - 8	42	x		44	28	3	8	14
3.5 - 29	1.1 - 9	4 - 33	1.2 - 10	4.1 - 34	1.2 - 10	83	x		28	28		11	
3 - 30	0.9 - 9	3 - 35	1.1 - 11	3.5 - 35	1.1 - 11	86	x		28	28		8, 11	15, 16
5.3 - 44	1.6 - 13	6 - 51	1.9 - 15	6.1 - 51	1.9 - 16	125	x	x	28	28		7, 10, 20	14
6 - 49	1.8 - 15	7 - 56	2.1 - 17	7 - 57	2.1 - 17	139	x	x	28	28	3		
6 - 60	1.8 - 18	7 - 69	2.1 - 21	7 - 70	2.1 - 21	173	x		28	28		8, 11	15, 16
9 - 77	2.7 - 23	10 - 89	3.2 - 27	10.4 - 89	3.2 - 27	139	x		44	28	3		
10 - 88	3.1 - 27	12 - 101	3.5 - 31	11.6 - 102	3.5 - 31	250	x	x	28	28		7, 10	14
10 - 104	3.1 - 32	12 - 120	3.5 - 36	11.6 - 121	3.5 - 37	173	x		48	28		8, 11	15, 16
12 - 121	3.7 - 37	14 - 139	4.2 - 42	13.9 - 140	4.2 - 43	345	x		28	28		8, 11	15, 16
17 - 138	5.2 - 42	20 - 159	6 - 48	19.7 - 160	6 - 49	250	x		44	28		7, 10	14
21 - 176	6.4 - 54	24 - 202	7.4 - 62	24.4 - 204	7.4 - 62	500	x	x	28	28		7, 10	14
26 - 264	7.9 - 81	30 - 304	9.1 - 93	30.2 - 306	9.2 - 93	345	x		48	22		8, 11	15, 16
33 - 276	10.1 - 84	38 - 317	11.6 - 97			500	x		44	28		7, 10	14
<b>CE</b> RPM from CE/50 Hz gearmotors VFD drive at 63 Max. Hz. output													
2.4 - 6	0.7 - 1.8	2.8 - 6.9	0.8 - 2.1	2.8 - 7	0.8 - 2.1	23*	x		19	32		9	
4.1 - 10	1.3 - 3.1	4.7 - 11.5	1.4 - 3.5	4.8 - 11.6	1.5 - 3.5	23*	x	x	28	28		9	
6 - 15	1.8 - 4.6	6.9 - 17.3	2.1 - 5.3	7 - 17.4	2.1 - 5.3	35*	x	x	28	28		9	
12 - 31	3.7 - 9.5	14 - 36	4.2 - 10.9	14 - 36	4.2 - 11	70*	x	x	28	28		9	
25 - 62	7.6 - 18.9	29 - 71	8.8 - 21.7	29 - 72	8.8 - 21.9	140*	x	x	28	28		9	
39 - 97	12 - 30	45 - 112	14 - 34	45 - 113	14 - 34	140*	x		44	28		9	
49 - 124	15 - 38	56 - 143	17 - 43	57 - 144	17 - 44	280*	x	x	28	28		9	
77 - 195	23 - 59	89 - 224	27 - 68	89 - 226	27 - 69	280*	x		44	28		9	
107 - 270	33 - 82	123 - 311	38 - 95			280*	x		48	22		9	

**Note:** Nose Bar transfers operate at maximum 77 ft/min (23.5 m/min) belt speed Red = Parallel Shaft, Blue = 90°

# 2200 & 2300 SERIES: FLUSH BOTTOM MOUNTING PACKAGES

Refer to the Gearmotor Selection Steps on page 40 for instructions on using the Belt Speed Charts.

## Flush Bottom Mount Package, Parallel Shaft Gearmotor

### Standard Load

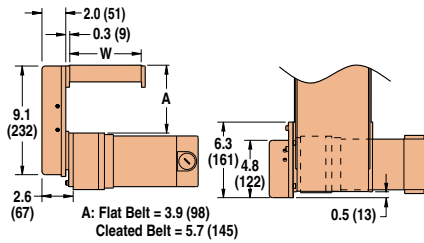

### Light Load

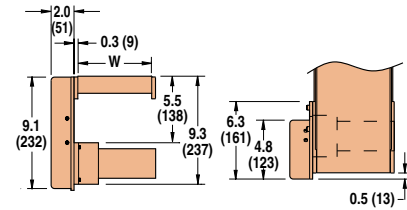

## Flush Bottom Mount Package, 90° Gearmotor

### Standard Load

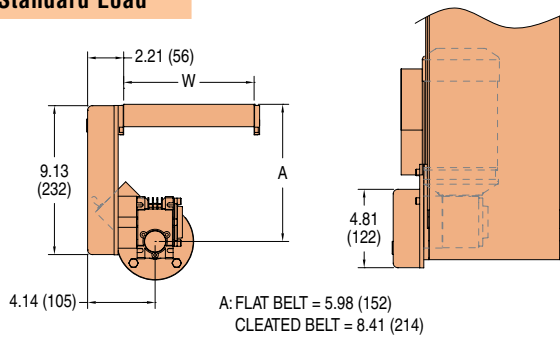

### Heavy Load

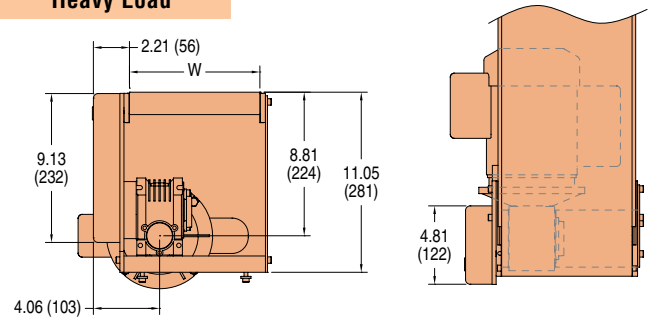

### Product Applications/Uses:

- Wide product transfers
- Product stops/escapements
- Product detection
- Lift stations
- Sheet handling

# 2200 & 2300 SERIES: FLUSH BOTTOM BELT SPEED CHARTS

Refer to the Gearmotor Selection Steps on page 40 for instructions on using the Belt Speed Charts.

Fixed Speed											
2200 / 2300		2200 Precision Move		2200 / 2300 Modular Belt		RPM From Gearmotor	Pulley Kit		Gearmotor Chart #		
Ft/min	m/min	Ft/min	m/min	Ft/min	m/min		Drive Pulley	Driven Pulley	Light Load	Standard Load	Heavy Load
5.9	1.8	6.8	2.1	6.8	2.1	10	28	16		5	
10.1	3.1	12	3.7	12	3.6	10	48	16		5	
18	5.5	21	6.4	21	6.4	29	28	16		4, 5	12, 13
28	8.5	32	9.8	32	9.9	29	44	16		4, 5	12, 13
25	7.6	29	8.8	29	8.8	42	28	16	1		
40	12.2	46	14	46	14.2	42	44	16	1		
41	12.5	47	14.3	48	14.5	43	44	16		4, 19	12, 13
55	16.8	63	19.2	64	19.5	58	44	16		5	
83	25.3	95	29.0	96	29.4	86	44	16		4, 5	12, 13
106	32.3	122	37.2	123	37.5	173	28	16		4, 5	12, 13
167	50.9	192	58.6	194	59.1	173	44	16		4, 5	12, 13
212	64.7	244	74.4	246	75.0	345	28	16		4, 5	12, 13
CE Gearmotor RPM at 50 Hz.											
14	4.3	16	4.9	16	5.0	23	28	16		6	
23	7.0	26	8.1	27	8.1	23	44	16		6	
34	10.4	39	11.9	39	12.0	35	44	16		6	
25	7.6	29	8.8	29	8.8	41	28	16	2		
39	11.9	45	13.7	45	13.8	41	44	16	2		
43	13.1	49	15.1	50	15.2	70	28	16		6	
67	20.4	77	23.5	78	23.7	70	44	16		6	
86	26.2	99	30.2	100	30.4	140	28	16		6	
135	41.2	155	47.4	157	47.8	140	44	16		6	
172	52.5	198	60.3	200	60.9	280	28	16		6	
270	82.4	311	94.7			280	44	16		6	

**Note:** Nose Bar transfers operate at maximum 77 ft/min (23.5 m/min) belt speed Red = Parallel Shaft, Blue = 90°

# 2200 & 2300 SERIES: FLUSH BOTTOM BELT SPEED CHARTS

Refer to the Gearmotor Selection Steps on page 40 for instructions on using the Belt Speed Charts.

Variable Speed											
2200 / 2300		2200 Precision Move		2200 / 2300 Modular Belt		RPM From Gearmotor	Pulley Kit		Gearmotor Chart #		
Ft/min	m/min	Ft/min	m/min	Ft/min	m/min		Drive Pulley	Driven Pulley	Light Load	Standard Load	Heavy Load
1.6 - 13	0.5 - 4	1.8 - 15	0.6 - 4.6	1.9 - 15.1	0.6 - 4.6	14	44	16		10	
2.8 - 28	0.9 - 8.5	3.2 - 32.2	1 - 9.8	3.2 - 32.5	1 - 9.9	29	44	16		8, 11	15, 16
3.1 - 26	1 - 8	4 - 30	1 - 9	4 - 30	1 - 9	42	28	16	3	7, 10	14
4.8 - 40	1 - 12	6 - 46	2 - 14	6 - 46	2 - 14	42	44	16	3	7, 10	14
4.2 - 42	1 - 13	5 - 48	1 - 15	5 - 49	1 - 15	43	44	16		8, 20	15, 16
7 - 60	2 - 18	8 - 69	2 - 21	8 - 70	2 - 21	63	44	16		7	14
10 - 81	3 - 25	12 - 93	4 - 28	12 - 94	4 - 29	83	44	16		10	
8 - 83	2 - 25	9 - 95	3 - 29	9 - 96	3 - 29	86	44	16		8, 11	15, 16
14 - 121	4 - 37	16 - 139	5 - 42	16 - 140	5 - 43	125	44	16		7, 10	14
10 - 85	3 - 26	12 - 98	4 - 30	12 - 99	4 - 30	139	28	16	3		
17 - 177	5 - 54	20 - 204	6 - 62	20 - 205	6 - 63	173	44	16		8, 11	15, 16
21 - 212	6 - 65	24 - 244	7 - 74	24 - 246	7 - 75	345	28	16		8, 11	15, 16
29 - 241	9 - 74	33 - 277	10 - 85			250	44	16		7, 10	14
 Gearmotor RPM at 50 Hz.											
7 - 18	2.1 - 5.5	8.1 - 20.7	2.5 - 6.3	8.1 - 20.9	2.5 - 6.4	23	28	16		9	
11 - 28	3.4 - 8.5	12.7 - 32.2	3.9 - 9.8	12.8 - 32.5	3.9 - 9.9	23	44	16		9	
17 - 43	5 - 13	20 - 49	6 - 15	20 - 50	6 - 15	35	44	16		9	
34 - 85	10 - 26	39 - 98	12 - 30	39 - 99	12 - 30	70	44	16		9	
43 - 108	13 - 33	49 - 124	15 - 38	50 - 125	15 - 38	140	28	16		9	
68 - 170	21 - 52	78 - 196	24 - 60	79 - 197	24 - 60	140	44	16		9	
86 - 216	26 - 66	99 - 248	30 - 76	100 - 251	30 - 76	280	28	16		9	

**Note:** Nose Bar transfers operate at maximum 77 ft/min (23.5 m/min) belt speed Red = Parallel Shaft, Blue = 90°



# 2200 & 2300 SERIES: GANG DRIVE & BOLSTER MOUNT MOUNTING PACKAGES

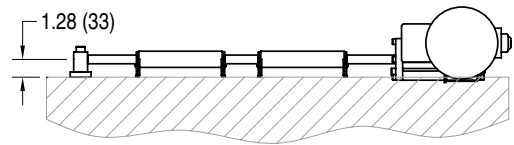
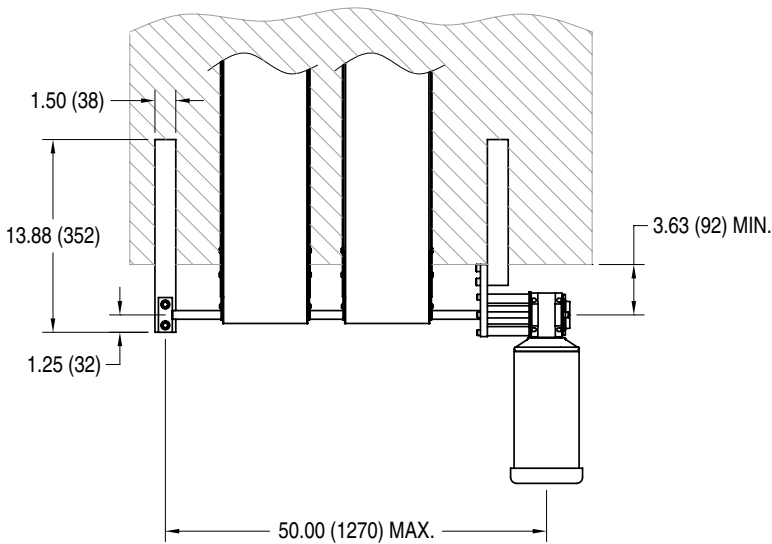

**Includes** motor mounting bracket, 4' (1219 mm) hex shaft, coupling, shaft guard, support block and support block bracket.

## Notes:

- Conveyors cannot be secured to bolster plate on stands
- Order conveyor with gang drive option separately
- Order garmotor separately (90° Standard and Heavy Load only)
- Positions 2 and 3 recommended

Note: Dimensions = in (mm)



### 2200 SERIES: BOLSTER MOUNT MOUNTING PACKAGE

63 M 01 E S

Motor Type: S, H, K  
 Output Shaft: 01 = Single  
 Documentation Language: M = English, U = CE English

**Example:** 63M01

**Description:** Gang drive mounting package with English documentation.

# 2200 & 2300 SERIES: GANG DRIVE & BOLSTER MOUNT BELT SPEED CHARTS

Refer to the Gearmotor Selection Steps on page 40 for instructions on using the Belt Speed Charts.

## 2200 BOLSTER MOUNT BELT SPEED CHARTS

### Fixed Speed

Belt Speed		RPM From Gearmotor	Gearmotor Chart #	
Ft/min	m/min		Standard Load	Heavy Load
8	2.4	29	4, 5	12, 13
12	3.7	43	4	12, 13
25	7.6	86	4, 5	12, 13
49	14.9	173	4, 5	12, 13
99	30.2	345	4, 5	12, 13

### CE Gearmotor RPM at 50 Hz

7	2.1	23	6	
10	3.0	35	6	
20	6.1	70	6	
40	12.2	140	6	
80	24.4	280	6	

### Variable Speed

Belt Speed		RPM From Gearmotor	Gearmotor Chart #	
Ft/min	m/min		Standard Load	Heavy Load
1.4 - 12	0.4 - 3.6	42	7, 10	14
2.1 - 18	0.7 - 5.4	63	7	14
4.3 - 36	1.3 - 11	125	7, 10	14
9 - 71	2.6 - 22	250	7, 10	14
17 - 143	5.2 - 43	500	7, 10	14

### CE Gearmotor RPM at 50 Hz

3.3 - 8	1.0 - 2.6	23	9	
5.0 - 13	1.5 - 3.8	35	9	
10 - 25	3.0 - 7.7	70	9	
20 - 50	6.1 - 15	140	9	
40 - 100	12.2 - 30	280	9	

**Note:** Nose Bar transfers operate at maximum 77 ft/min (23.5 m/min) belt speed Red = Parallel Shaft, Blue = 90°

## GANG MID DRIVE BELT SPEED CHARTS

Refer to page 32 for mount package details.

### Fixed Speed

2200 Precision Move		RPM From Gearmotor	Gearmotor Chart	
Ft/min	m/min		Standard Load	Heavy Load
15	4.6	29	4	12
23	7.0	43	4	12
45	13.7	86	4	12
91	27.8	173	4	12
181	55.2	345	4	12

### CE Gearmotor RPM at 50 Hz

12	3.7	23	6	
18	5.5	35	6	
37	11.3	70	6	
73	22.3	140	6	
147	44.8	280	6	

### Variable Speed

Belt Speed		RPM From Gearmotor	Gearmotor Chart	
Ft/min	m/min		Standard Load	Heavy Load
2 - 15	0.6 - 4.6	29	8	15
3 - 22	0.9 - 6.7	42	7	14
3 - 23	0.9 - 7	43	8	15
4 - 33	1.2 - 10.1	63	7	14
5 - 45	1.5 - 13.7	86	8	15
7 - 66	2.1 - 20.1	125	7	14
9 - 91	2.7 - 27.8	173	8	15
13 - 131	4 - 40	250	7	14
18 - 181	5.5 - 55.2	345	8	15
26 - 262	7.9 - 79.9	500	7	14

### CE RPM from CE/50 Hz gearmotors VFD drive at 63 Max. Hz. output

6 - 15	1.8 - 4.6	23	9	
9 - 23	2.7 - 7	35	9	
19 - 47	5.8 - 14.3	70	9	
37 - 92	11.3 - 28.1	140	9	
74 - 185	22.6 - 56.4	280	9	

Red = Parallel Shaft, Blue = 90°

# 2200 & 2300 SERIES: CENTER & MID DRIVE MOUNTING PACKAGES

Refer to the Gearmotor Selection Steps on page 40 for instructions on using the Belt Speed Charts.

## CENTER DRIVE MOUNTING PACKAGES

### TYPE 1 - Vertical Mount

#### Parallel Shaft Gearmotor

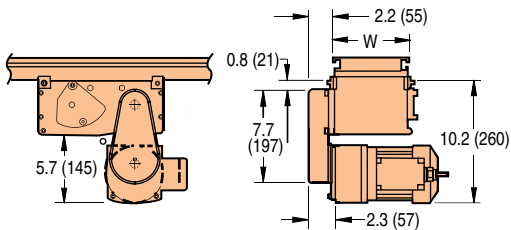

### TYPE 2 - Horizontal Mount

#### Parallel Shaft Gearmotor

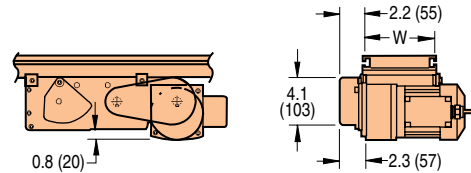

### 90° Gearmotor

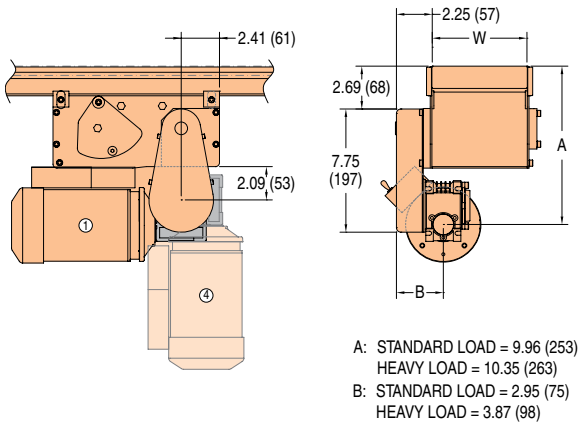

### 90° Gearmotor

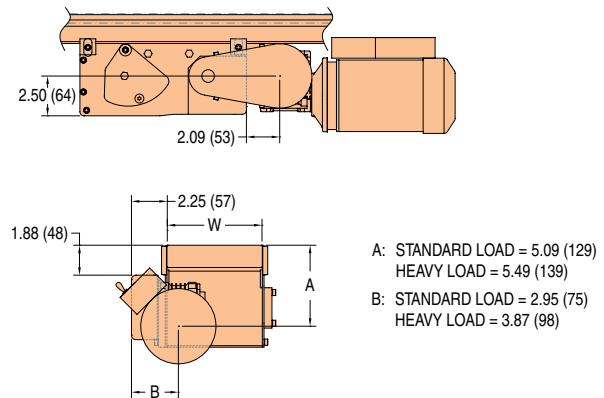

TYPE 2 recommended for tight spaces and allows for easy access to the drive module.

\* Gearmotor not included in mounting package, see page 40 for gearmotor ordering information. Dimensions = in (mm)

For ordering information, see page 79

## 2200 PRECISION MOVE MID DRIVE

### Parallel Shaft Gearmotor

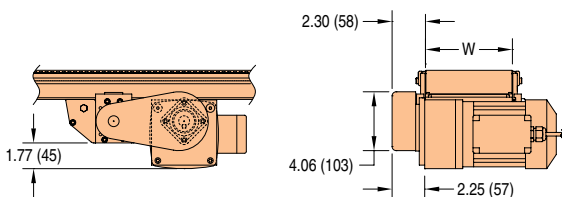

### 90° Gearmotor

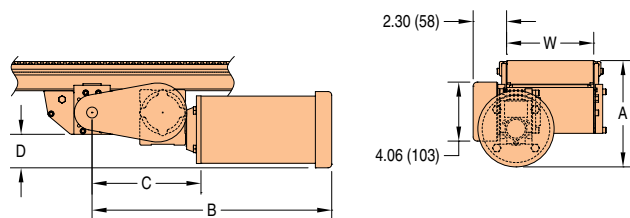

A: STANDARD LOAD = 7.32 (186)  
HEAVY LOAD = 8.40 (213)  
B: STANDARD LOAD = 7.50 (190)  
HEAVY LOAD = 8.01 (203)  
C: STANDARD LOAD = 16.50 (419)  
HEAVY LOAD = 17.72 (450)  
D: STANDARD LOAD = 2.31 (59)  
HEAVY LOAD = 3.39 (86)

For ordering information, see page 80

# 2200 & 2300 SERIES: CENTER & MID DRIVE BELT SPEED CHARTS

Refer to the Gearmotor Selection Steps on page 40 for instructions on using the Belt Speed Charts.

Fixed Speed										
2200 / 2300		2200 Precision Move		2200 / 2300 Modular Belt		RPM From Gearmotor	Pulley Kit		Gearmotor Chart #	
Ft/min	m/min	Ft/min	m/min	Ft/min	m/min		Drive Pulley	Driven Pulley	Standard Load	Heavy Load
2	0.6	3.1	0.9	2.3	0.7	10	22	32	5	
3	0.9	4.6	1.4	3.5	1.1	10	32	32	5	
6	1.8	9.2	2.8	7.0	2.1	29	19	32	4	11, 12
10	3.1	15.3	4.7	11.6	3.5	29	32	32	4, 5	11, 12
15	4.6	23	7.0	17	5.3	43	32	32	4, 19	11, 12
20	6.1	31	9.3	23	7.1	58	32	32	5	
23	7.0	35	10.7	27	8.1	43	48	32	4	11, 12
30	9.2	46	14.0	35	10.6	86	32	32	4, 5	11, 12
61	18.6	93	28.5	71	21.6	173	32	32	4, 5	11, 12
91	27.8	139	42.5	106	32.2	173	48	32	4, 5	11, 12
121	36.9	185	56.5	140	42.8	345	32	32	4, 5	11, 12
154	47.0	236	71.9	179	54.5	345	28	22	4, 5	11, 12
181	55.2	277	84.5	210	64.0	345	48	28	4, 5	11, 12
208	63.4	318	97.1	241	73.6	345	48	28	4, 5	11, 12
264	80.5	404	123.2			345	48	22	4, 5	11, 12
 Gearmotor RPM at 50 Hz.										
5	1.5	7.7	2.3	5.8	1.8	23	19	32	6	
8	2.4	12.2	3.7	9.3	2.8	23	32	32	6	
12	3.7	18.4	5.6	13.9	4.2	35	32	32	6	
18	5.5	27.5	8.4	20.9	6.4	35	48	32	6	
25	7.6	38	11.7	29	8.8	70	32	32	6	
37	11.3	57	17.3	43	13.1	70	48	32	6	
49	14.9	75	22.9	57	17.3	140	32	32	6	
74	22.6	113	34.5	86	26.2	140	48	32	6	
98	29.9	150	45.7	114	34.7	280	32	32	6	
148	45.1	226	69.1	172	52.4	280	48	32	6	
169	51.5	259	78.9	196	59.8	280	48	28	6	
214	65.3	327	99.9	248	75.7	280	48	22	6	
248	75.6	379	115.7	288	87.7	280	48	19	6	

**Note:** Nose Bar transfers operate at maximum 77 ft/min (23.5 m/min) belt speed Red = Parallel Shaft, Blue = 90°

# 2200 & 2300 SERIES: CENTER & MID DRIVE BELT SPEED CHARTS

Refer to the Gearmotor Selection Steps on page 40 for instructions on using the Belt Speed Charts.

Variable Speed										
2200 / 2300		2200 Precision Move		2200 / 2300 Modular Belt		RPM From Gearmotor	Pulley Kit		Gearmotor Chart #	
Ft/min	m/min	Ft/min	m/min	Ft/min	m/min		Drive Pulley	Driven Pulley	Standard Load	Heavy Load
0.4 - 3.4	0.1 - 1	0.6 - 5.2	0.2 - 1.6	0.5 - 3.9	0.1 - 1.2	14	22	32	10	
0.6 - 4.9	0.2 - 1.5	0.9 - 7.5	0.3 - 2.3	0.7 - 5.7	0.2 - 1.7	14	32	32	10	
0.7 - 6	0.2 - 1.8	1.1 - 9.2	0.3 - 2.8	0.8 - 7	0.2 - 2.1	29	19	32	8	15, 16
1 - 9	0.3 - 2.7	1.5 - 13.8	0.5 - 4.2	1.2 - 10.4	0.4 - 3.2	42	19	32	7, 10	14
1.2 - 10	0.4 - 3.1	1.8 - 15.3	0.6 - 4.7	1.4 - 11.6	0.4 - 3.5	29	32	32	8, 11	15, 16
1.8 - 15	0.5 - 4.6	2.8 - 23	0.8 - 7	2.1 - 17.4	0.6 - 5.3	42	32	32	7, 10	14
1.8 - 15	0.5 - 4.6	2.8 - 23	0.8 - 7	2.1 - 17.4	0.6 - 5.3	43	32	32	8, 20	15, 16
2.6 - 22	0.8 - 6.7	4 - 33.7	1.2 - 10.3	3 - 25.5	0.9 - 7.8	63	32	32	7	14
3.5 - 29	1.1 - 9	5 - 44	2 - 14	4 - 34	1 - 10	83	32	32	10	
3.6 - 30	1.1 - 9	6 - 46	2 - 14	4 - 35	1 - 11	86	32	32	8, 11	15, 16
5.3 - 44	1.6 - 13	8 - 67	2 - 21	6 - 51	2 - 16	125	32	32	7, 10	14
7 - 61	2.1 - 19	11 - 93	3 - 28	8 - 71	2 - 22	173	32	32	8, 11	15, 16
10 - 88	3.1 - 27	15 - 135	5 - 41	12 - 102	4 - 31	250	32	32	7, 10	14
12 - 104	3.7 - 32	18 - 159	6 - 49	14 - 121	4 - 37	173	48	28	8, 11	15, 16
14 - 121	4.3 - 37	21 - 185	7 - 56	16 - 140	5 - 43	345	32	32	8, 11	15, 16
18 - 150	5.5 - 46	28 - 230	8 - 70	21 - 174	6 - 53	250	48	28	7, 10	14
21 - 176	6.4 - 54	32 - 269	10 - 82	24 - 204	7 - 62	500	32	32	7, 10	14
23 - 190	7 - 58	35 - 291	11 - 89	27 - 220	8 - 67	345	44	28	8, 11	15, 16
27 - 224	8.2 - 68	41 - 343	13 - 105	31 - 260	10 - 79	500	28	22	7, 10	14
29 - 242	8.8 - 74	44 - 370	14 - 113			345	44	22	8, 11	15, 16
31 - 255	9.5 - 78	47 - 390	14 - 119			500	32	22	7, 10	14
 RPM from 50 Hz. gearmotors, VFD drive at 63 max. Hz. output.										
2.4 - 6	0.7 - 1.8	3.7 - 9.2	1.1 - 2.8	2.8 - 7	0.8 - 2.1	23	19	32	9	
4.1 - 10	1.3 - 3.1	6.3 - 15.3	1.9 - 4.7	4.8 - 11.6	1.5 - 3.5	23	32	32	9	
6 - 16	1.8 - 4.9	9.2 - 24.5	2.8 - 7.5	7 - 18.6	2.1 - 5.7	35	32	32	9	
12 - 31	3.7 - 9	18 - 47	6 - 14	14 - 36	4 - 11	70	32	32	9	
24 - 62	7.3 - 19	37 - 95	11 - 29	28 - 72	8 - 22	140	32	32	9	
37 - 93	11.3 - 28	57 - 142	17 - 43	43 - 108	13 - 33	140	48	32	9	
49 - 124	14.9 - 38	75 - 190	23 - 58	57 - 144	17 - 44	280	32	32	9	
74 - 186	22.6 - 57	113 - 285	35 - 87	86 - 216	26 - 66	280	48	32	9	
98 - 248	29.9 - 76	150 - 379	46 - 116	114 - 288	35 - 88	280	44	22	9	

**Note:** Nose Bar transfers operate at maximum 77 ft/min (23.5 m/min) belt speed Red = Parallel Shaft, Blue = 90°

## LIGHT LOAD, FIXED SPEED

**Chart 1** Parallel Shaft

- Sealed gearmotor
- Totally enclosed, non-ventilated
- Includes switch, cord and overload protection on 1 Phase unit
- 115V, 1 Phase
- 230V, 3 Phase
- Non-reversing
- 60 Hz

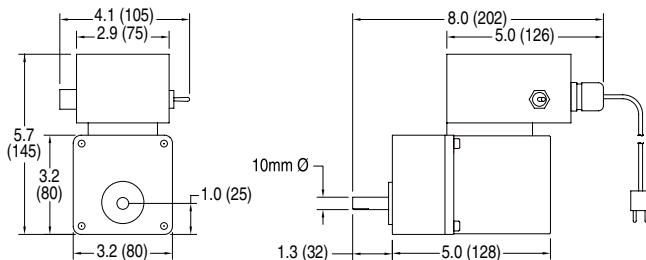

Part Number	RPM	Gearmotor Type	Hp	kW	1 Phase			3 Phase			Starter Chart
					FLA	in.-lbs.	Nm	FLA	in.-lbs.	Nm	
62M036PL4(vp)F(N)	42	L	0.03	0.025	0.46	26	2.9	0.22	37	4.2	H
62M015PL4(vp)F(N)	100	L	0.03	0.025	0.46	12	1.4	0.22	16.8	1.9	H

(vp) = Voltage and Phase 11 = 115V, 1 phase 23 = 230V, 3 phase (n) = Reversing capability **N** = No reversing switch **R** = With reversing switch

**Chart 2** CE Parallel Shaft

- Totally enclosed, fan cooled
- IP44 protection rating
- Non-reversing
- 50 Hz
- Order starter separately, see page 61

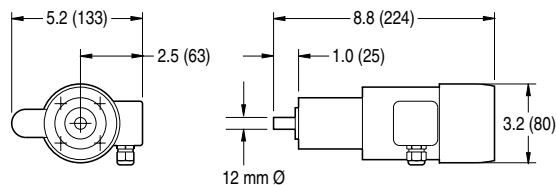

Part Number	RPM	Gearmotor Type	1Ph kW	1 Ph FLA	3Ph kW	3 Ph FLA	Nm	3 Phase Starter Chart
62Z028PL421FN	41	L	0.022	0.31	n/a	n/a	2.6	H
62Z028PL4(vp)FN	41	L	n/a	n/a	0.020	0.22 / 0.13	3.5	H
62Z008PL421FN	144	L	0.022	0.31	n/a	n/a	0.9	H
62Z008PL4(vp)FN	144	L	n/a	n/a	0.020	0.22 / 0.13	1.2	H

(vp) = Voltage and Phase  
23 = 230V, 3 phase 43 = 400V, 3 phase

**CE Note:** When buying a gearmotor only without the starter, the customer must supply their own on/off switch and motor overload protection to comply with the CE Safety Directive.

**FLA** = Full Load Amperes

Some motors and gear reducers may normally operate hot to the touch. Consult factory for specific operating temperatures. Note: Dimensions = in (mm)

# 2200 & 2300 SERIES: GEARMOTORS

## LIGHT LOAD, VARIABLE SPEED

**Chart 3** Parallel Shaft

- 130 Volts DC
- Sealed gearmotor
- Totally enclosed, non-ventilated
- 300 - 2500 RPM motor
- Order controller separately, see page 60

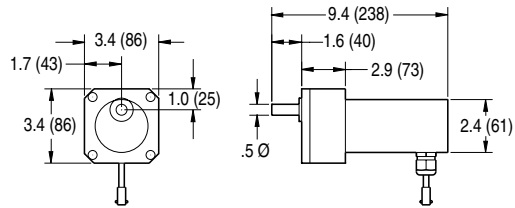

Part Number	RPM	Gearmotor Type	Hp	kW	FLA	in.-lbs.	Nm	Vari - Speed Control Chart
62M060PLD3DEN	42	V	0.06	0.04	0.48	65	7.3	A
62M018PLD3DEN	139	V	0.06	0.04	0.48	21	2.4	A

**Chart 18** Parallel Shaft

- VFD Variable Speed
- 230V, 3 Phase, 10 to 60 Hz
- Totally enclosed, non-ventilated
- Order controller separately, see page 60

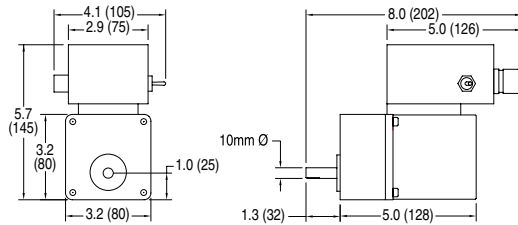

Part Number	RPM	Gearmotor Type	Hp	kW	FLA	in.-lbs.	Nm	Vari - Speed Control Chart
62M036PL423EN	42	L	0.03	0.025	0.22	37	4.2	E
62M015PL423EN	100	L	0.03	0.025	0.22	16.8	1.9	E

## STANDARD LOAD, FIXED SPEED

**Chart 4** 90°

- Sealed gearmotor
- NEMA 42 CZ C Face
- Totally enclosed, fan cooled
- 115V 1 phase includes switch, cord and overload protection
- 208-230/460 Volts, 3 phase wiring by others
- 60 Hz
- Order 3 phase starter separately, see page 61



**eDrive®**

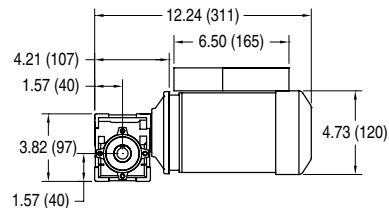
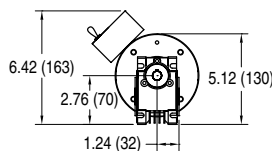

Part Number	RPM	Gearmotor Type	1 Phase			3 Phase			in.-lbs.	Nm	3 Phase Starter Chart
			Hp	kW	FLA	Hp	kW	FLA			
32M060EL4(vp)FN	29	S	0.25	0.19	5	0.25	0.19	1.2 / 0.6	226	25.5	L
32M040EL4(vp)FN	43	S	0.25	0.19	5	0.25	0.19	1.2 / 0.6	237	26.8	L
32M020EL4(vp)FN	86	S	0.25	0.19	5	0.25	0.19	1.2 / 0.6	142	16.0	L
32M010EL4(vp)FN	173	S	0.25	0.19	5	0.25	0.19	1.2 / 0.6	78	8.8	L
32M005EL4(vp)FN	345	S	0.25	0.19	5	0.25	0.19	1.2 / 0.6	41	4.6	L

(vp) = Voltage and Phase 11 = 115V, 1 phase 23 = 208 - 230 / 460V, 3 phase

**FLA** = Full Load Amperes

Some motors and gear reducers may normally operate hot to the touch. Consult factory for specific operating temperatures. Note: Dimensions = in (mm)

## STANDARD LOAD, FIXED SPEED

**Chart 5** Parallel Shaft

- Sealed gearmotor
- Totally enclosed, fan cooled
- 115V 1 phase includes switch, cord and overload protection
- 230/460 Volts, 3 phase wiring by others
- 60 Hz
- Order 3 phase starter separately, see page 61

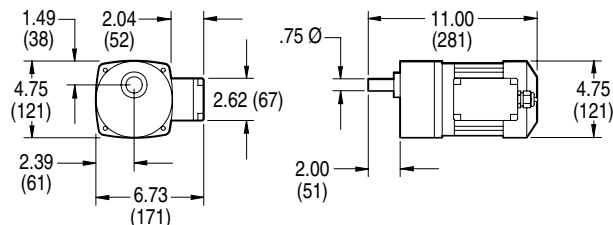

Part Number	RPM	Gearmotor Type	1 Phase				3 Phase				Nm	3 Phase Starter Chart
			Hp	kW	FLA	in.-lbs.	Hp	kW	FLA	in.-lbs.		
62M180PS4(vp)F(n)	10	S	0.08	0.06	1.2	341	0.17	0.13	1.0 / 0.5	341	38.5	L
62M060PS4(vp)F(n)	29	S	0.17	0.13	1.9	270	0.17	0.13	1.0 / 0.5	270	30.5	L
62M030PS4(vp)F(n)	58	S	0.17	0.13	1.9	135	0.38	0.28	1.9 / 0.95	250	15.3	M
62M020PS4(vp)F(n)	86	S	0.17	0.13	1.9	90	0.38	0.28	1.9 / 0.95	167	10.2	M
62M010PS4(vp)F(n)	173	S	0.17	0.13	1.9	45	0.38	0.28	1.9 / 0.95	115	5.1	M
62M005PS4(vp)F(n)	345	S	0.17	0.13	1.9	25	0.38	0.28	1.9 / 0.95	58	2.8	M

(vp) = Voltage and Phase 11 = 115V, 1 phase 23 = 230/460V, 3 phase  
 (n) = Reversing Capability N = No reversing switch R = With reversing switch (115V, 1 phase only)

**Chart 6** CE 90°

- Sealed gearmotor
- IEC 63 B5 C Face
- IP 55 protection rating
- Totally enclosed, fan cooled
- Non-reversing
- 50 Hz
- Order starter separately, see page 61

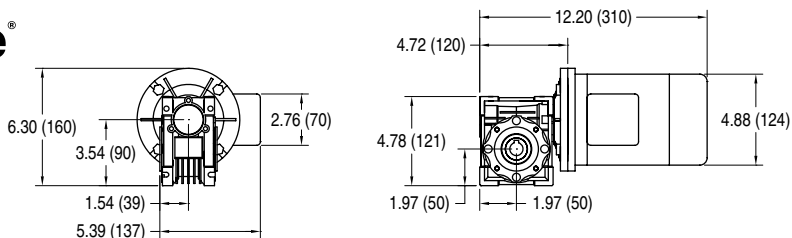

Part Number	RPM	Gearmotor Type	1Ph kW	1 Ph FLA	3 Ph kW	3 Ph FLA	Nm	Starter Chart
62Z060ES4(vp)FN	23	S	0.18	1.6	0.25	1.4 / 0.94	26.4	I
62Z040ES4(vp)FN	35	S	0.18	1.6	0.25	1.4 / 0.94	28.9	I
62Z020ES4(vp)FN	70	S	0.18	1.6	0.25	1.4 / 0.94	19.4	I
62Z010ES4(vp)FN	140	S	0.18	1.6	0.25	1.4 / 0.94	10.7	I
62Z005ES4(vp)FN	280	S	0.18	1.6	0.25	1.4 / 0.94	5.6	I

(vp) = Voltage and Phase 21 = 230V, 1 phase  
 23 = 230V, 3 phase 43 = 400V, 3 phase

**CE Note:** When buying a gearmotor only without the starter, the customer must supply their own on/off switch and motor overload protection to comply with the CE Safety Directive.

**FLA = Full Load Amperes** Some motors and gear reducers may normally operate hot to the touch. Consult factory for specific operating temperatures.  
 Note: Dimensions = in (mm)



# 2200 & 2300 SERIES: GEARMOTORS

## STANDARD LOAD, FIXED SPEED

**Chart 19** 90°

- SEW WA20 Gearmotor
- Bottom, Center and Side mount packages available
- 230 / 460 V 3 Phase
- VFD Compatible with constant torque from 10 to 60 Hz
- Sealed gear head, totally enclosed fan cooled motor

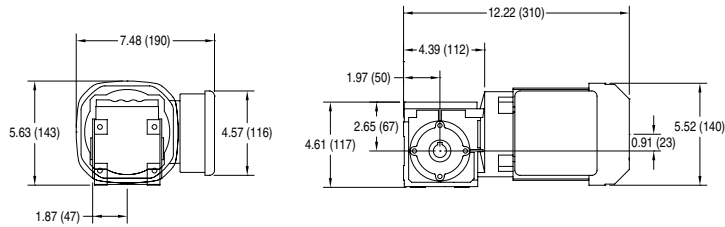

Part Number	RPM	Gearmotor Type	Hp	kW	FLA	in.-lbs	Nm	3 Phase Starter Chart
22M039WS423EN	46	W	0.25	0.19	0.89 / 0.44	203	22.9	L
22M017WS423EN	109	W	0.33	0.25	1.24 / 0.62	159	18.0	L
22M008WS423EN	219	W	0.50	0.37	1.84 / 0.92	132	14.9	M

## STANDARD LOAD, VARIABLE SPEED

**Chart 7** 90°

- 130 Volts DC
- Sealed gearmotor
- NEMA 42 CZ C Face
- Totally enclosed, fan cooled
- 300 - 2500 RPM motor
- Order controller separately, see page 60

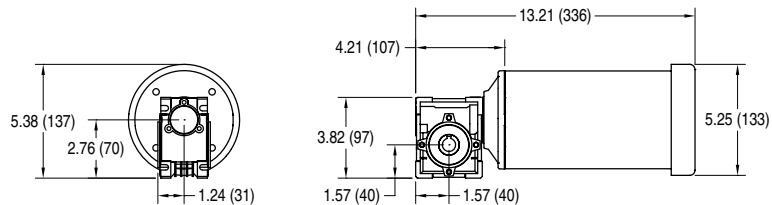

Part Number	RPM	Gearmotor Type	Hp	kW	FLA	in.-lbs.	Nm	Vari-Speed Control Chart
22M060ESD3DEN	42	S	0.33	0.25	2.3	198	22.4	A
22M040ESD3DEN	63	S	0.33	0.25	2.3	163	18.4	A
22M020ESD3DEN	125	S	0.33	0.25	2.3	98	11.1	A
22M010ESD3DEN	250	S	0.33	0.25	2.3	54	6.1	A
22M005ESD3DEN	500	S	0.33	0.25	2.3	28	3.2	A

**Chart 8** 90°

- Variable frequency drive, 6 - 60 Hz
- Sealed gearmotor
- NEMA 56C C Face
- Totally enclosed, fan cooled
- 230/460 Volts, 3 phase
- Order controller separately, see pages 60 & 61

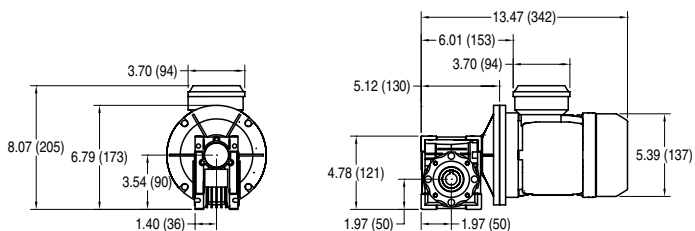

Part Number	RPM	Gearmotor Type	Hp	kW	FLA	in.-lbs.	Nm*	Vari-Speed Control Chart
32M060EL423EN	29	K	0.5**	0.37	1.6 / 0.97	226	25.5	D and E
32M040EL423EN	43	K	0.5**	0.37	1.6 / 0.97	237	86.8	D and E
32M020EL423EN	86	K	0.5**	0.37	1.6 / 0.97	142	16.0	D and E
32M010EL423EN	173	K	0.5**	0.37	1.6 / 0.97	78	8.8	D and E
32M005EL423EN	345	K	0.5**	0.37	1.6 / 0.97	41	4.6	D and E

\* = At 60 Hz \*\* = Motor de-rated to 0.25 Hp for full torque throughout speed range.

**FLA** = Full Load Amperes

Some motors and gear reducers may normally operate hot to the touch. Consult factory for specific operating temperatures. Note: Dimensions = in (mm)

# 2200 & 2300 SERIES: GEARMOTORS

## STANDARD LOAD, VARIABLE SPEED

**Chart 9**    **CE 90°**

- Variable frequency drive, 25-63 Hz
- Sealed gearmotor
- IEC 63 B5 C Face
- IP 55 protection rating
- Totally enclosed, fan cooled
- 230/400 Volts, 3 phase
- Order controller separately, see page 60

**eDrive®**

Part Number	RPM	Gearmotor Type	3 Ph kW	3 Ph FLA	Nm*	Vari-Speed Control Chart
62Z060ES423EN	23	S	0.25	1.4 / 0.94	26.4	B
62Z040ES423EN	35	S	0.25	1.4 / 0.94	28.9	B
62Z020ES423EN	70	S	0.25	1.4 / 0.94	19.4	B
62Z010ES423EN	140	S	0.25	1.4 / 0.94	10.7	B
62Z005ES423EN	280	S	0.25	1.4 / 0.94	5.6	B

\* = At 50 Hz

**CE Note:** When buying a gearmotor only without the starter, the customer must supply their own on/off switch and motor overload protection to comply with the CE Safety Directive.

**Chart 10**    **Parallel Shaft**

- 130 Volts DC
- Sealed gearmotor
- Totally enclosed, non-ventilated
- 300 - 2500 RPM motor
- Order controller separately, see page 60

Part Number	RPM	Gearmotor Type	Hp	kW	FLA	in.-lbs.	Nm	Vari - Speed Control Chart
62M180PSD3DEN	14	S	0.12	0.09	1.0	341	38.5	A
62M060PSD3DEN	42	S	0.25	0.19	1.8	270	30.5	A
62M030PSD3DEN	83	S	0.25	0.19	1.8	135	15.3	A
62M020PSD3DEN	125	S	0.25	0.19	1.8	90	10.2	A
62M010PSD3DEN	250	S	0.33	0.25	2.3	72	8.1	A
62M005PSD3DEN	500	S	0.25	0.19	1.8	25	2.8	A

**Chart 11**    **Parallel Shaft**

- Variable frequency drive, 10 to 60 Hz
- Sealed gearmotor
- Totally enclosed, fan cooled
- 230/460 Volts / 3 Phase, VFD duty
- Order controller separately, see pages 60 & 61

Part Number	RPM*	Gearmotor Type	Hp	kW	FLA	in.-lbs.	Nm	Vari - Speed Control Chart
62M180PS423EN	10	S	0.17	0.13	1.0 / 0.5	341	38.5	D and E
62M060PS423EN	29	S	0.17	0.13	1.0 / 0.5	270	30.5	D and E
62M030PS423EN	58	S	0.38	0.28	1.9 / 0.95	250	28.3	D and E
62M020PS423EN	86	S	0.38	0.28	1.9 / 0.95	167	18.9	D and E
62M010PS423EN	173	S	0.38	0.28	1.9 / 0.95	115	13.0	D and E
62M005PS423EN	345	S	0.38	0.28	1.9 / 0.95	58	6.5	D and E

\* = At 60 Hz

**FLA = Full Load Amperes** Some motors and gear reducers may normally operate hot to the touch. Consult factory for specific operating temperatures.  
Note: Dimensions = in (mm)

# 2200 & 2300 SERIES: GEARMOTORS

## STANDARD LOAD, VARIABLE SPEED

Chart 20

90°

- SEW WA20 Gearmotor
- Bottom, Center and Side mount packages available
- 230 / 460 V 3 Phase
- VFD Compatible with constant torque from 10 to 60 Hz
- Sealed gear head, totally enclosed fan cooled motor

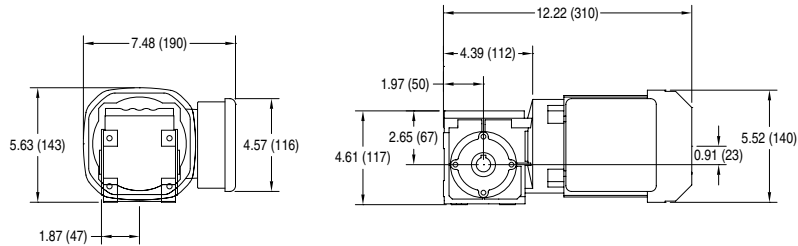

Part Number	RPM	Gearmotor Type	Hp	kW	FLA	in.-lbs	Nm	Vari - Speed Control Chart
22M039WS423EN	46	W	0.25	0.19	0.89 / 0.44	203	22.9	D and E
22M017WS423EN	109	W	0.33	0.25	1.24 / 0.62	159	18.0	D and E
22M008WS423EN	219	W	0.50	0.37	1.84 / 0.92	132	14.9	D and E

## HEAVY LOAD, FIXED SPEED

Chart 12

90°

- Sealed gearmotor
- NEMA 56 C Face
- Totally enclosed, fan cooled
- 115V 1 phase includes switch, cord and overload protection
- 208-230/460 Volts, 3 phase wiring by others
- 60 Hz
- Order 3 phase starter separately, see page 61

eDrive®

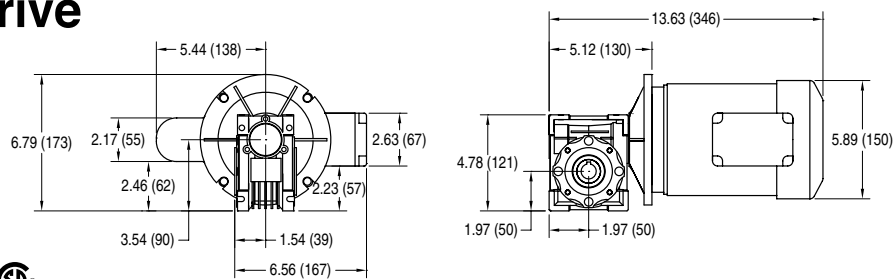

Part Number	RPM	Gearmotor Type	1 Phase			3 Phase			in.-lbs.	Nm	3 Phase Starter Chart
			Hp	kW	FLA	Hp	kW	FLA			
32M060ES4(vp)FN	29	H	0.5	0.37	7.4	0.5	0.37	2.1-2 / 1.0	226	25.5	M
32M040ES4(vp)FN	43	H	0.5	0.37	7.4	0.5	0.37	2.1-2 / 1.0	247	27.9	M
32M020ES4(vp)FN	86	H	0.5	0.37	7.4	0.5	0.37	2.1-2 / 1.0	248	27.9	M
32M010ES4(vp)FN	173	H	0.5	0.37	7.4	0.5	0.37	2.1-2 / 1.0	156	17.6	M
32M005ES4(vp)FN	345	H	0.5	0.37	7.4	0.5	0.37	2.1-2 / 1.0	81	9.1	M

(vp) = Voltage and Phase 11 = 115V, 1 phase 23 = 208 - 230 / 460V, 3 phase

**FLA** = Full Load Amperes Some motors and gear reducers may normally operate hot to the touch. Consult factory for specific operating temperatures.

Note: Dimensions = in (mm)

## HEAVY LOAD, VARIABLE SPEED

**Chart 14** 90°

- 90V DC
- Sealed gearmotor
- NEMA 56 C Face
- Totally enclosed, fan cooled
- 300 - 2500 RPM motor
- Order controller separately, see page 60

**eDrive®**

6.85 (174) 2.75 (70) 3.54 (90) 2.17 (55) 1.54 (39) 5.92 (150) 5.12 (130) 14.83 (377) 4.78 (121) 6.20 (157) 1.97 (50) 1.97 (50)

Part Number	RPM	Gearmotor Type	Hp	kW	FLA	in.-lbs.	Nm	Vari - Speed Control Chart
32M060ESD9DEN	42	H	0.5	0.37	5.0	198	22.4	C
32M040ESD9DEN	63	H	0.5	0.37	5.0	215	24.3	C
32M020ESD9DEN	125	H	0.5	0.37	5.0	196	22.1	C
62M010EHD9DEN	250	H	0.75	0.50	7.5	108	12.2	C
62M005EHD9DEN	500	H	0.75	0.50	7.5	56	6.3	C

**Chart 15** 90°

- Variable frequency drive, 6 - 60 Hz
- Sealed gearmotor
- NEMA 56 C Face
- Totally enclosed, fan cooled
- 230/460 Volts, 3 Phase
- Order controller separately, see pages 60 & 61

**eDrive®**

4.59 (116) 8.92 (227) 6.79 (173) 3.54 (90) 1.54 (39) 5.12 (130) 14.89 (378) 4.13 (105) 4.78 (121) 6.00 (152) 1.97 (50) 1.97 (50)

Part Number	RPM*	Gearmotor Type	3 Ph Hp	3 Ph kW	3 Ph FLA	in.-lbs.*	Nm*	Vari - Speed Control Chart
32M060ES423EN	29	H	0.75**	0.55	2.6 / 1.3	226	25.5	D and E
32M040ES423EN	43	H	0.75**	0.55	2.6 / 1.3	247	27.9	D and E
32M020ES423EN	86	H	0.75**	0.55	2.6 / 1.3	248	27.9	D and E
32M010ES423EN	173	H	0.75**	0.55	2.6 / 1.3	156	17.6	D and E
32M005ES423EN	345	H	0.75**	0.55	2.6 / 1.3	81	9.1	D and E

\* = At 60 Hz      \*\* = Motor derated to 0.5 hp (2.2 / 1.1 amp) for full torque throughout speed range

**FLA** = Full Load Amperes    Note: Dimensions = in (mm)

# 2200 & 2300 SERIES: VARIABLE SPEED CONTROLLERS

## VARIABLE SPEED CONTROLLERS

### Chart A

- PWM DC control
- Nema 1 enclosure
- Line cord and motor cord
- On/Off switch for 62MD1134
- Forward/Off/Reverse switch for 62MD1134R
- Speed potentiometer
- Mounting hardware

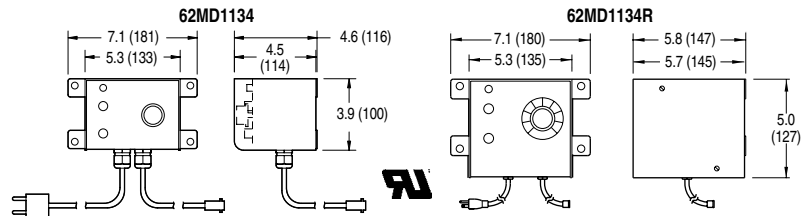

\* = See FLA from motor charts

Part Number	Input Volts	Input Phase	Input Hz	Output Volts	Max Amps*	Reversing
62MD1134	115	1	60	130VDC	3.2	No
62MD1134R	115	1	60	130VDC	5.0	Yes

### Chart B



- VFD control
- IP 65 enclosure
- EMC filter
- Mounting hardware
- Variable speed
- Motor cord only on 460V
- Line cord and motor cord

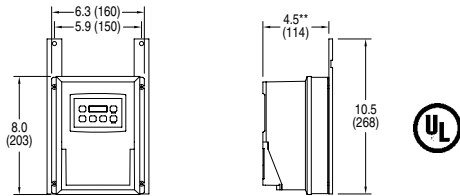

Part Number	Input Volts	Input Phase	Input Hz	Output Volts	Output Phase	Max Kw*	Max Amps	Reversing
62UV2121	230	1	50	230	3	0.75	4.2	Yes
62UV4341	400	3	50	400	3	0.75	2.1	Yes

### Chart C

- PWM DC control
- NEMA 1 enclosure
- Line cord and motor cord
- On/Off switch for 62MD1192 & 62MD1193
- Forward/Off/Reverse switch for 62MD1192R & 62MD1193R
- Speed potentiometer
- Mounting hardware

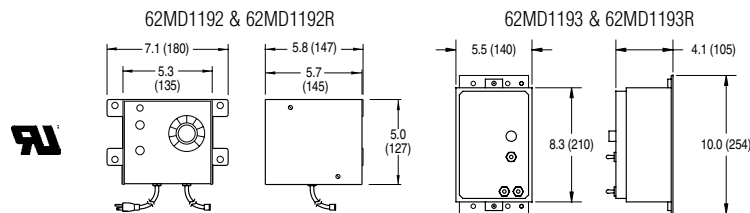

\* = See FLA from motor charts

Part Number	Input Volts	Input Phase	Input Hz	Output Volts	Max Amps*	Reversing
62MD1192	115	1	60	90VDC	5.0	No
62MD1192R	115	1	60	90VDC	5.0	Yes
62MD1193	115	1	60	90VDC	7.5	No
62MD1193R	115	1	60	90VDC	7.5	Yes

### Chart D

- Full feature VFD control
- NEMA 4 enclosure
- Digital display
- Keypad with Start/Stop, Forward/Reverse and speed variations
- Includes cord to motor
- Power to controller by others
- 32MV1122 includes line cord to controller
- Mounting hardware

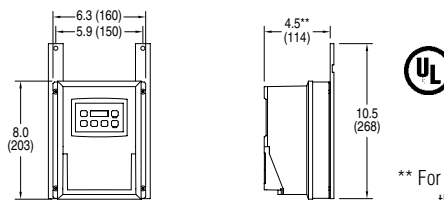

\* = See FLA from motor charts

\*\* For VFD 32MV2127 and 32MV2327 the width dimension is 6.4 (163).

Part Number	Input Volts	Input Phase	Input Hz	Output Volts	Output Phase	Max Hp	Output Amps*	Reversing
32MV1122	115	1	60	230	3	0.5	2.2	Yes
32MV2122	230	1	60	230	3	0.5	2.2	Yes
32MV1121	115	1	60	230	3	1.0	4.0	Yes
32MV2121	230	1	60	230	3	1.0	4.0	Yes
32MV2127**	230	1	60	230	3	2.0	6.8	Yes
32MV2322	230	3	60	230	3	0.5	2.2	Yes
32MV2327**	230	3	60	230	3	2.0	6.8	Yes
32MV4341	460	3	60	460	3	1.0	2.0	Yes
32MV4347	460	3	60	460	3	2.0	3.4	Yes

Note: Dimensions = in (mm)

# 2200 & 2300 SERIES: MANUAL MOTOR STARTERS

## VARIABLE SPEED CONTROLLERS

**Chart E**

- VFD control
- Nema 1 enclosure
- Line cord and motor cord
- On/Off switch
- Speed potentiometer
- Mounting hardware
- Forward/Reverse switch

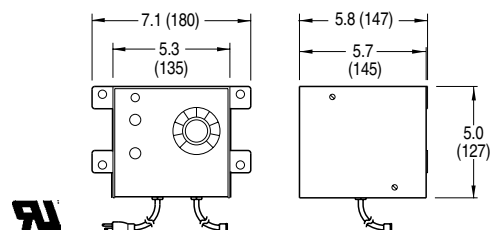

Part Number	Input Volts	Input Phase	Input Hz	Output Volts	Output Phase	Max Hp	Max Amps*	Reversing
62MV1122B	115	1	60	230	3	0.5	2.4	No
62MV1122BR	115	1	60	230	3	0.5	2.4	Yes

## MANUAL MOTOR STARTERS

Manual motor starts are manual electronic disconnects that provide motor overload protection and are required by the National Electric Code (NEC) for safe motor operation.

**Illustration A**

**Illustration B**

- IP 55 Enclosure
- Push button Start / Stop
- Includes mounting hardware

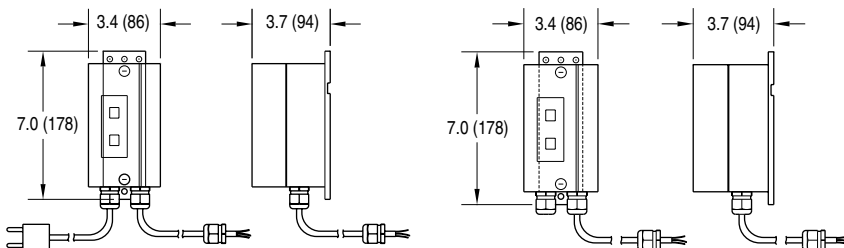

**Chart H** CE

- 230V, 1 phase includes cord, plug & starter
- 230/400 Volts, 3 phase wiring to starter by others
- Wiring between motor and starter provided when ordered together
- 50 Hz

Part Number	In Volts	In Phase	Amp Range	Illustration
62(c)M21H	230	1	0.25 - 0.4	A
62(c)M23H	230	3	0.16 - 0.25	B
62(c)M43H	400	3	0.1 - 0.16	B

**Chart I** CE

- 230V, 1 phase includes cord, plug and starter
- 230/400 Volts, 3 phase wiring to starter by others
- Wiring between motor and starter provided when ordered together
- 50 Hz

Part Number	In Volts	In Phase	Amp Range	Illustration
62(c)M21T	230	1	1.6 - 2.5	A
62(c)M23T	230	3	1.0 - 1.6	B
62(c)M43T	400	3	0.63 - 1.0	B

**CE Note:** When buying a gearmotor only without the starter, the customer must supply their own on/off switch and motor overload protection to comply with NEC and CE safety directive.

(c) = Electrical Configuration G = CE German  
F = CE French U = CE Great Britain

**Chart L**

- 230/460 Volts, 3 phase wiring to starter by others
- Wiring between motor and starter provided when ordered together
- 60 Hz

Part Number	In Volts	In Phase	Amp Range	Illustration
62MM23L	230	3	1.0 - 1.6	B
62MM43L	460	3	0.4 - 0.63	B
62MM23H	230	3	0.16 - 0.25	B

**Chart M**

- 230/460 Volts, 3 phase wiring to starter by others
- Wiring between motor and starter provided when ordered together
- 60 Hz

Part Number	In Volts	In Phase	Amp Range	Illustration
62MM23M	208 - 230	3	1.6 - 2.5	B
62MM43M	460	3	1.0 - 1.6	B

Note: Dimensions = in (mm)

# 2200 & 2300 SERIES: SUPPORT STANDS

## QUANTITY CHARTS

### 2200 Series Support Stands

Conveyor Length	# of Supports
2' (610) - 4' (1,219)	1*
2' (610) - 6' (1,829)	2
7' (2,134) - 12' (3,658)	3
13' (3,962) - 18' (5,486)	4
19' (5,791) - 24' (7,315)	5

### 2300 Series Support Stands

Conveyor Length	# of Supports
2' (610) - 8' (2,438)	2
9' (2,743) - 16' (4,877)	3
17' (5,182) - 24' (7,315)	4

### Required Return Roller Quantity Chart

Max feet between return rollers

Conveyor Width	1.75"	2.75"	3.75"	5"	6"	8"	10"	12"	18"	21"	24"
Flat Belt	8.75	8.5	7.5	7.25	7.0	6.75	6.5	6.0	5.5	5.0	4.5
Cleated Belt	5.75	5.5	5.25	5.0	4.75	4.5	4.25	4.0	3.5	3.25	3.0

Quantity of return rollers required = whole number result of:  $\frac{\text{conveyor length in feet}}{\text{max distance between return rollers}}$

**Example Description:** 2200 flat belt 8" wide x 14' long  $\frac{14'}{6.75} = 2.07$  **2 return rollers required**

\* End Drive Conveyors with Single-Post Support Stands only. Requires the use of diagonal bracing, see page 63. Heavy load gearmotors require a minimum of two stands to support conveyor and gearmotor package.

## MOUNTING BRACKETS

### Cleated Belt Stand Mounting Bracket

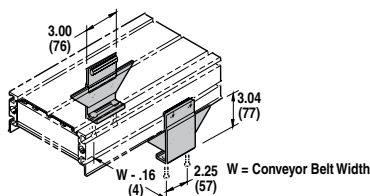

Part Number	Description
240838	Stand Mounting Bracket, 2200 Series Cleated Belt Conveyor
715645	Stand Mounting Bracket, 2300 Series Cleated Belt Conveyor

### Flat Belt Stand Mounting Bracket

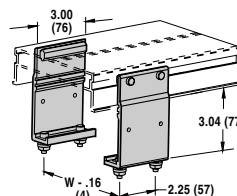

Part Number	Description
240839	Stand Mounting Bracket, 2200 Series Flat Belt Conveyor
715642	Stand Mounting Bracket, 2300 Series Flat Belt Conveyor

**Note:** Conveyors can be ordered with the required number of mounting brackets. If desired, order additional mounting brackets separately.

## RETURN ROLLERS

### Cleated Belt Return Roller

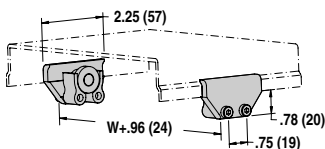

Part Number	Description
240832	Return Roller for 2200 & 2300 Series, Cleated Belt

### Flat Belt Return Roller for 2" to 6" Wide Conveyors

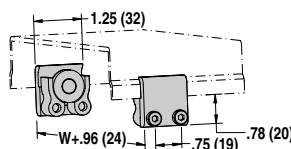

Part Number	Description
240830	Return Roller for 2200 & 2300 Series 2" (44 mm) to 6" (152 mm) wide Flat Belt Conveyor

### Flat Belt Return Roller for 8" to 48" Wide Conveyors

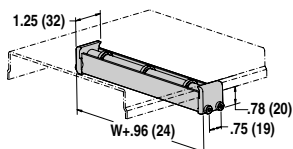

Part Number	Description
3249WW	Return Roller for 2200 & 2300 Series 8" (203 mm) to 48" (1,219 mm) wide Flat Belt Conveyor

**WW** = Conveyor Width Reference

**Note:** Conveyors can be ordered with the required number of mounting brackets. If desired, order additional mounting brackets separately.

**Note:** Due to the wide variety of conveyor and stand options along with possible configurations, stability of the final setup is the responsibility of the end user.

Note: Dimensions = in (mm)

## STAND ACCESSORIES

### Adjustable Tie Bracket

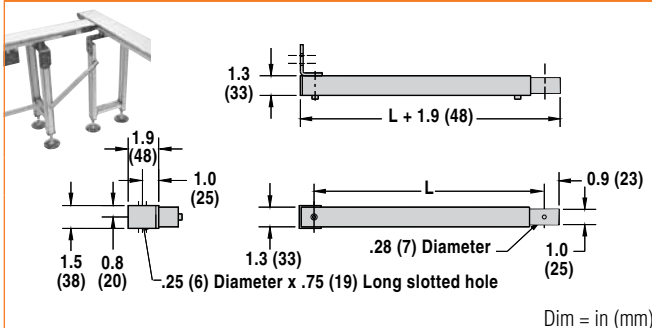

- Compatible with steel and aluminum support stands
- Secure critical stand and conveyor locations
- Length (L) adjusts + 0", - 11.25" (286 mm)
- Includes metric mounting hardware

### Bottom Mount Stand Bracket

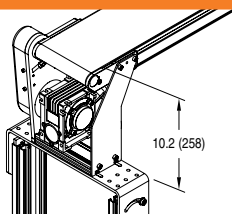

\*Not compatible with MB option.

- Bolts to 90° standard load gearmotor
- Includes metric mounting hardware
- Provides a 10.2" (258) T.O.B. Height

Part Number	Description
202306-02	"L" Bracket only for 2" to 5" wide conveyors
202306-WW	Bracket Assembly, 06 and wider 2200 & 2300 conveyors

### Diagonal Bracing



\*Not compatible with MB option.

- For use on steel, aluminum and single post support stands with casters
- Metric fastener mounting hardware included
- For use on all stands with casters and any stands over 72" (1829 mm) tall
- One brace per stand for conveyors up to 24" wide (610 mm)
- Two braces per stand for conveyors over 24" wide (610 mm)

2200 Part Number	2300 Part Number	Description
39MB-TS	39MB-FS	for two-legged H style & A-Frame stands up to 30" tall (762 mm)
39MB-TT	39MB-FT	for two-legged H style & A-Frame stands over 30" tall (762 mm)
39MB-PT	39MB-PT	for Single Post and Pillar stands over 30" tall (762 mm)

### Common Mount Kit

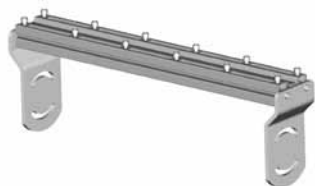

- Stand accessory for mounting multiple conveyors in parallel to one stand
- Adds 2" (51 mm) to stand height
- Adds 2.79" (71 mm) to overall stand width

For ordering information, see page 81

### Tall Support Stands



Outriggers

Tall Stands are the Fixed Height and Adjustable Height Stands as shown with additional outrigger support for added stability. These outriggers are required when the height of the stand exceeds 3.5x its width, and they add 16" to stand width. Tall stands over 6' tall include diagonal bracing.

### Fine Adjustment Kit

- Provides fine height adjustment via a threaded bolt
- For use with Fixed Height Stands



Part # 710028



# 2200 & 2300 SERIES: SUPPORT STANDS

## FIXED HEIGHT SUPPORT STANDS

### Fixed Foot Model

Stand Width (WW)	12" (305mm)	2" (51mm) increments up to...	48" (1,219mm)
Part # Reference	12	in 02 increments up to...	48
Stand Height (HH)*	15" - 19" (381 - 483mm)	in 1" (25mm) increments up to...	95" - 99" (2,413 - 2,515mm)
Part # Reference	1519	in 0101 increments up to...	9599

### Swivel Locking Caster Model

Stand Width (WW)	12" (305mm)	2" (51mm) increments up to...	48" (1,219mm)
Part # Reference	12	in 02 increments up to...	48
Stand Height (HH)*	20" - 24" (508 - 610mm)	in 1" (25mm) increments up to...	68" - 72" (1,727 - 1,829mm)
Part # Reference	2024	in 0101 increments up to...	6872

- Metric fasteners
- 4" (102 mm) Height Adjustment

\* Dependent on stand width, stands over 42" (1,067 mm) may include outriggers (see page 63)

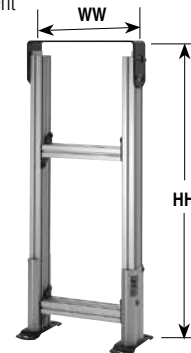

Full width is top plate on 12" wide stands only

## ADJUSTABLE HEIGHT SUPPORT STANDS

### Fixed Foot Model

Stand Width (WW)	12" (305mm)		2" (51mm) increments up to...				48" (1,219mm)				
Part # Reference	12		in 02 increments up to...				48				
Stand Height (HH)	12-13" (305-330)	13-15" (330-381)	14-17" (356-432)	16-21" (406-660)	19-26" (483-686)	24-36" (610-914)	30-48" (762-1,219)	42-60"* (1,067-1,524)	54-72"* (1,372-1,829)	66-84"* (1,676-2,134)	78-96"* (1,981-2,438)
Part # Reference	1213	1315	1417	1621	1926	2436	3048	4260	5472	6684	7896

### Swivel Locking Caster Model

Stand Width (WW)	12" (305mm)		2" (51mm) increments up to...				48" (1,219mm)				
Part # Reference	12		in 02 increments up to...				48				
Stand Height (HH)	17-18" (432-457)	18-20" (457-508)	19-22" (483-559)	21-26" (533-660)	24-31" (610-787)	29-41" (737-1,041)	35-53" (762-1,346)	47-65"* (1,194-1,651)	59-77"* (1,499-1,956)		
Part # Reference	1718	1820	1922	2126	2431	2941	3553	4765	5977		

- Metric fasteners

\* Dependent on stand width, stands over 42" (1,067 mm) may include outriggers (see page 63)

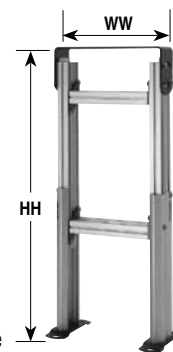

Full width is top plate on 12" wide stands only

## SINGLE POST & PILLAR SUPPORT STANDS

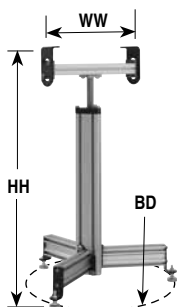

Single Post Support Stand

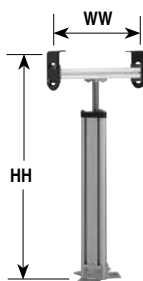

Pillar Stand  
(must be secured to floor)

### Standard Sizes

Stand Width (WW)	1.75" (44)	2.75" (70)	3.75" (95)	5" (44)	6" (152)	8" (203)	10" (254)	12" (305)	14" (356)	16" (406)	18" (457)
Part # Reference	02	03	04	05	06	08	10	12	14	16	18
Stand Height (HH)*	16-26" (406-660)		24-34" (610-864)		32-42" (813-1,067)		40-50" (1,016-1,270)		48-58" (1,219-1,473)		
Part # Reference	16		24		32		40		48		
Base Diameter (BD)	24" (610)		27" (686)		30" (762)		33" (838)		36" (915)		

- Casters do not change overall height
- Metric fasteners

**Note:** Due to the wide variety of conveyor and stand options along with possible configurations, stability of the final setup is the responsibility of the end user.

For ordering information, see page 81

# 2200 & 2300 SERIES: SUPPORT STANDS

## SHORT SUPPORT STANDS

### Fixed Foot Model

Stand Width (WW)	12" (305mm)	2" (51mm) increments up to...	48" (1,219mm)
Part # Reference	12	in 02 increments up to...	48
Stand Height (HH)*	06" - 08" (152 - 203mm)	in 1" (25mm) increments up to...	12" - 14" (305 - 356mm)
Part # Reference	0608	in 0101 increments up to...	1214

### Swivel Locking Caster Model

Stand Width (WW)	12" (305mm)	2" (51mm) increments up to...	48" (1,219mm)
Part # Reference	12	in 02 increments up to...	48
Stand Height (HH)*	11" - 13" (279 - 330mm)	in 1" (25mm) increments up to...	17" - 19" (305 - 483mm)
Part # Reference	1113	in 0101 increments up to...	1719

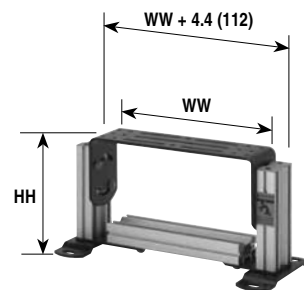

Full width is top plate on 12" wide stands only

## FULLY ADJUSTABLE SUPPORT STANDS

### Fixed Foot Model

Stand Width (WW)	1.75" (44)	2.75" (70)	3.75" (95)	5" (44)	6" (152)	2" (51mm) increments up to...	48" (1,219)
Part # Reference	02	03	04	05	06	in 02 increments up to...	48
Top of Belt Range	7-19" (179-483)		12-31" (305-787)		12-43" (305-1,097)	12-55" (305-1,397)	12-67" (305-1,702)
Stand Height Reference	0719		1231		1243	1255	1267

### Swivel Locking Caster Model

Stand Width (WW)	1.75" (44)	2.75" (70)	3.75" (95)	5" (44)	6" (152)	2" (51mm) increments up to...	48" (1,219)
Part # Reference	02	03	04	05	06	in 02 increments up to...	48
Top of Belt Range	12-19" (305-483)		17-31" (432-787)		17-43" (432-1,097)	17-55" (432-1,397)	17-67" (432-1,702)
Stand Height Reference	1219		1731		1743	1755	1767

- Metric fasteners

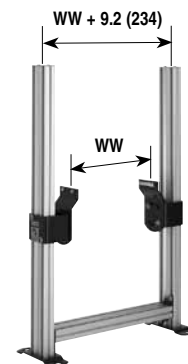

## MULTI TIER STANDS

### Minimum Tier Height Per Conveyor

Flat Belt	12" (305mm)
Cleated Belt	15" (381mm)

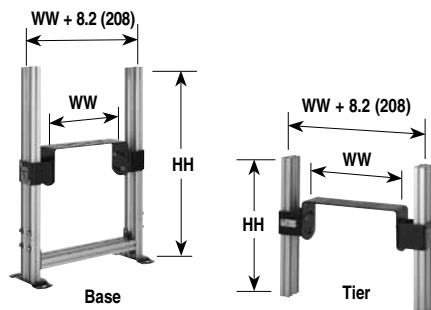

Full width is top plate on 12" wide stands only

### Base

Stand Width (WW)	12" (305mm)	2" (51mm) increments up to...	48" (1,219mm)
Part # Reference	12	in 02 increments up to...	48
Stand Height (HH)*	12" (305mm)	2" (51mm) increments up to...	60" (1,524mm)
Part # Reference	1212	in 0002 increments up to...	1260

### Tier

Stand Width (WW)	12" (305mm)	2" (51mm) increments up to...	48" (1,219mm)
Part # Reference	12	in 02 increments up to...	48
Stand Height (HH)*	12" (305mm)	1" (25mm) increments up to...	36" (914mm)
Part # Reference	0712	in 0002 increments up to...	0736

**Note:** Do not use with support stands equipped with casters. Support Stands must be anchored to the floor. Do not use if conveyed product overhangs the edge of the conveyor belt due to pinch point created.

**Note:** Due to the wide variety of conveyor and stand options along with possible configurations, stability of the final setup is the responsibility of the end user.

# 2200 & 2300 SERIES: SUPPORT STANDS

## QUICK ADJUST STANDS

### Fixed Foot Model

Stand Width (WW)*	12" (305mm)	2" (51mm) increments <b>up to...</b>	36" (914mm)
Part # Reference	12	in 02 increments <b>up to...</b>	36
Stand Height (HH)*	24" - 30" (610 - 762mm)	in 1" (25mm) increments <b>up to...</b>	66" - 72" (1,676 - 1,829mm)
Part # Reference	2430	in 0101 increments <b>up to...</b>	6672

### Swivel Locking Caster Model

Stand Width (WW)*	12" (305mm)	2" (51mm) increments <b>up to...</b>	36" (914mm)
Part # Reference	12	in 02 increments <b>up to...</b>	36
Stand Height (HH)*	27" - 33" (686 - 838mm)	in 1" (25mm) increments <b>up to...</b>	60" - 66" (1,524 - 1,676mm)
Part # Reference	2733	in 0101 increments <b>up to...</b>	6066

\* Under 12" wide use full top plate option

- Metric fasteners
- ± 3" (76 mm) Height Adjustment
- Allows for Quick Height Adjustment
- Tool-less lock and adjustment handles



Fixed Foot Model

Swivel Locking Caster Model

## A-FRAME STANDS

### Fixed Foot Model

Stand Width (WW)	1.75" (44mm)	2" (51mm) increments <b>up to...</b>	24" (610mm)
Part # Reference	02	in 02 increments <b>up to...</b>	24
Stand Height (HH)*	10" - 14" (254 - 356mm)	in 1" (25mm) increments <b>up to...</b>	56" - 60" (1,422 - 1,524mm)
Part # Reference	1014	in 0101 increments <b>up to...</b>	5660

### Swivel Locking Caster Model

Stand Width (WW)	1.75" (44mm)	2" (51mm) increments <b>up to...</b>	24" (610mm)
Part # Reference	02	in 02 increments <b>up to...</b>	24
Stand Height (HH)*	13" - 15" (330 - 381mm)	in 1" (25mm) increments <b>up to...</b>	58" - 60" (1,473 - 1,524mm)
Part # Reference	2733	in 0101 increments <b>up to...</b>	5860

\* From floor to top of belt

- Metric fasteners
- ± 2" (51 mm) Height Adjustment for Fixed Foot Model
- ± 1" (25 mm) Height Adjustment for Fixed Foot Model
- One (1) SmartSlot per side



Fixed Foot Model

Swivel Locking Caster Model

Note: Dimensions = in (mm)

Due to the wide variety of drive set ups and applications, point of installation guarding is the responsibility of the end user.

**Note:** Due to the wide variety of conveyor and stand options along with possible configurations, stability of the final setup is the responsibility of the end user.

For ordering information, see page 81

## CANTILEVER STAND MOUNT

### Specifications:

- Widths: 2" (51 mm) to 24" (610 mm) available in 1" increments
- Conveyors up to 6" wide are supported with a single cantilever bracket only
- Conveyors 8" and wider include a pivoting outboard support post

### Features:

- Mounts the conveyor from one side only for quick maintenance of the conveyor belt
- Compatible with the 2200 and 3200 Series Conveyors
- (2) Models
  - Table Top Bracket
  - Support Stand Mount Bracket



Easy Access for Quick Belt Removal



6" and narrower



8" and wider

**Note:** Due to the wide variety of conveyor and stand options along with possible configurations, stability of the final setup is the responsibility of the end user.

### 2200 SERIES: CANTILEVER STAND MOUNT

39 MCB WW - T

Mount Type: T = Table Top Mount S = Support Stand Mount  
Belt Width: 02-24

## ADJUSTABLE LANE GUIDING

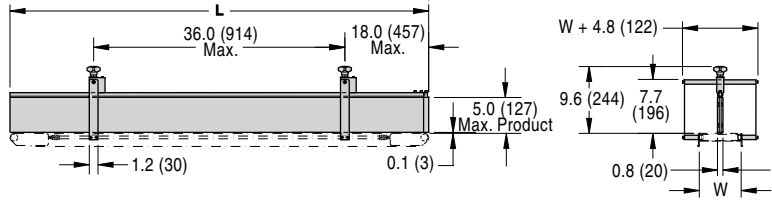

### Specifications:

- UHMW guide surface on an anodized aluminum mounting rail
- Painted Steel mounting hardware
- Available in standard 1' (305 mm) increments or can be ordered to any length
- 5" (127 mm) maximum, 0.25" (7 mm) minimum part height
- 0.25" (6mm) minimum lane width
- Package includes (1) lane guide, mounting hardware and adjusting knobs
- For conveyors up to 24" (610 mm) wide – Consult factory for wider lane guide availability
- Metric fasteners only

**Important:** Exceeding 5" (127 mm) product height will produce a pinch point.

### Features & Benefits:

- Compatible with standard Dorner bolt-on profiles
- Easily adjusts for quick product change over
- Attach additional guides to create multiple lanes
- Create lanes, plows, merges and transfers
- Order additional lane kits separately

#### 2200 & 2300 SERIES: ADJUSTABLE LANE GUIDING

27M GGG - 06 LL

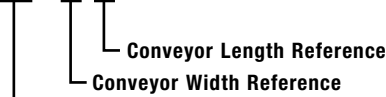

**Guide Type:**

- 500** = 2200 Package    **502** = Additional Lane Kit for 2200
- 503** = MB Package    **504** = Additional Lane Kit for MB

**Example:** 27M500-0620

## SIDE TABLES

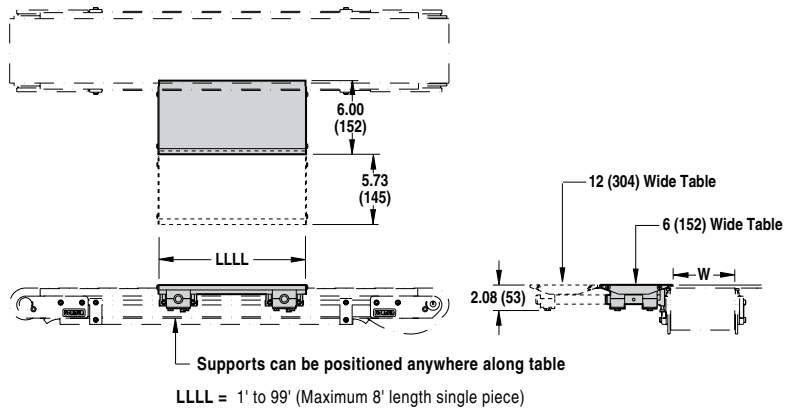

### Specifications:

- Provides a 6" (152 mm) or 12" (305 mm) wide working surface
- Adjusts in/out and up/down (0.25" max above bedplate) for product transfer on/off conveyor belts
- Can be positioned anywhere along the conveyor
- Anodized aluminum work surface
- Max load: 5 lbs/ft (6 kg/m), use Adjustable Tie Brackets for added capacity
- Available in 1' (305 mm) increments from 1' (305 mm) to 99' (30,175 mm)
- Compatible with 2200, 3200 and 5200 Series Conveyors

#### 2200 & 2300 SERIES: SIDE TABLES

27M TTT - 06 LLLL



**Conveyor / Table Type:** **601** = 2200, one side

- 602** = 2200, two sides    **603** = MB, one side    **604** = MB, two sides

**Example:** 27M601-060300

Note: Dimensions = in (mm)

**Note:** Due to the wide variety of conveyor and stand options along with possible configurations, stability of the final setup is the responsibility of the end user.

## 90° ADJUSTABLE TRANSFER

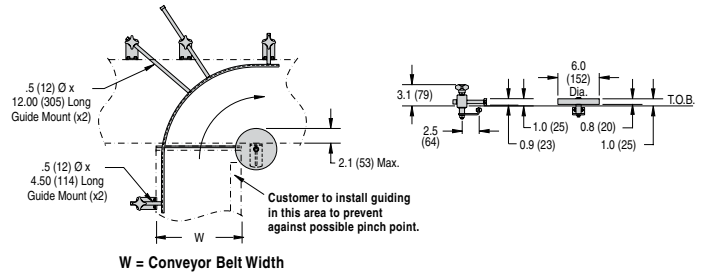

### Specifications:

- For conveyors up to 12" (305 mm) wide
- Requires low side conveyors
- 0.25" (6 mm) minimum part thickness
- Hard coat anodized transfer plate
- Painted steel mounting hardware
- 48" (1,219 mm) long UHMW outside turn guide, customer can trim to fit
- Maximum recommended part weight is 20 lbs (9 kg) at 50 ft/min (15 m/min) belt speed. Consult factory regarding applications for higher product weights or faster belt speeds.
- 0.88" (22 mm) minimum product size for 2200 & 2300 Series
- Package includes outside turn guide, guide wheel, adjustable mounting hardware and extruded aluminum transfer plate

### Features & Benefits:

- Pre-engineered guided turns adjust to a variety of products
- Accepts standard Dorner bolt-on profiles outside of transfer area
- Place adjusting rods where required
- Easily adjusts for quick product change-over
- Metric fasteners only

#### 2200 & 2300 SERIES: 90° ADJUSTABLE TRANSFER

27M 2201 - 06

└ Infeed Conveyor Width Reference

Example: 27M2201-06

**Note:** Due to the wide variety of drive setups and applications point of installation guarding is the responsibility of the end user.

**Important:** Do not use with 03, 08, 55, 62, or 64 High Friction Belts on Infeed conveyor

\* Not compatible with MB option

## HARDWARE ACCESSORIES

### Spring T-Nut

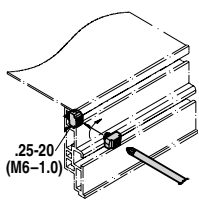

- Mounts in T-slots to attach light weight accessories
- Recommended for vertical aluminum stand T-slots

Part Number	Description
200124	Spring T-nut, 0.25-20
200124M	Spring T-nut, M6-1.0
200300	Package of 5 Spring T-nuts, 0.25-20
200300M	Package of 5 Spring T-nuts, M6-1.0

### T-Slot Extenders

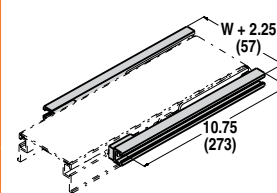

- Provides additional T-slots to the end of conveyor
- Includes mounting brackets and hardware
- Metric fasteners

Part Number	Description
307000M	T-Slot Extender, Pair

### 2200 Series T-Bars

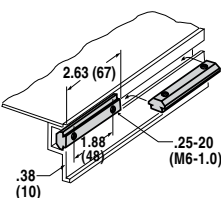

- Mounts in T-slots to attach heavy accessories
- 2.63" (67 mm) long 2 hole model, 0.75" (19 mm) 1 hole model

Part Number	Description
639971	1 hole T-bar, 0.25-20
639971M	1 hole T-bar, M6-1.0
300150	2 hole T-bar, 0.25-20
300150M	2 hole T-bar, M6-1.0

### T-Slot Cover

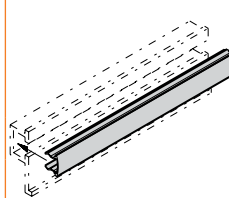

- Snaps into conveyor and aluminum stand T-slots
- Black plastic extrusion
- Can be trimmed to fit

Part Number	Description
645656P	T-Slot Cover, Per 1' (305 mm) of length

Note: Dimensions = in (mm)

# 2200 & 2300 SERIES: ACCESSORIES

## PULLEY TRANSFER PLATE\*



### Specifications:

- 0.88" (22 mm) diameter minimum product transfer for 2200 & 2300 Series
- Hard coat anodized finish
- Package includes extruded aluminum transfer plate, required pulley tail plates and mounting hardware
- Metric fasteners only

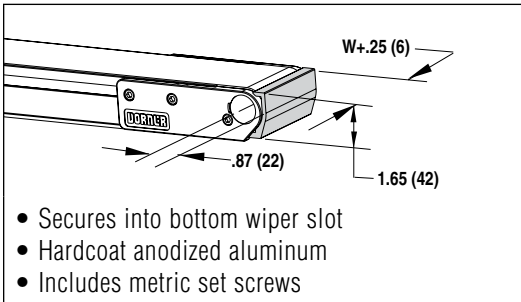

### 2200 & 2300 SERIES: PULLEY TRANSFER PLATE

27M 2200 - 06

Conveyor Width Reference

**Example:** 27M2200-06

- \* Not compatible with Gang Drive or MB option
- \* Not compatible with clipper splice or high friction belts
- \* Not compatible with cleated belt conveyors

*Due to the wide variety of drive set ups and applications, point of installation guarding is the responsibility of the end user.*

## HARDWARE ACCESSORIES

### Bottom Wiper\*

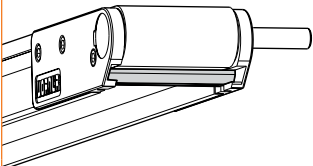

- Locate at discharge end of conveyor
- 0.25" (6 mm) thick steel
- Removes debris from belt
- Includes metric set screws

Part Number	Description
2225WWM	2200 & 2300 Series Bottom Wiper

**WW** = Conveyor Width Reference

**Note:** Bottom wiper standard on 2200 Gang Drive Conveyor

- \* Not compatible with MB option or high friction belts
- \* Not compatible with cleated belt conveyors

### 2300 Series DustPruf Self Drilling Screw

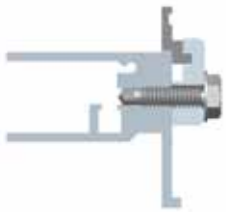

- Self drilling in SmartSlot®
- For attachment of heavy accessories or supports

Part Number	Thickness of Mounting Plate
715652	0 - 1/8" (3 mm)
715653	1/8 (3 mm) - 1/2" (13 mm)
715654	5/8 (16 mm) - 1" (25 mm)

Note: Dimensions = in (mm)

## SIDE GUIDES

### Flared Side Guide

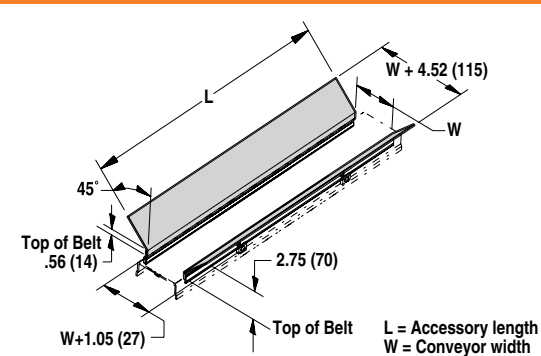

- Guides parts onto conveyor belt surface
- Includes metric mounting hardware
- Compatible with 2200 & 2300 Series

Part Number	Description
280802M	2' (610 mm) Flared Side
280803M	3' (914 mm) Flared Side
280804M	4' (1,219 mm) Flared Side
280805M	5' (1,524 mm) Flared Side
280806M	6' (1,829 mm) Flared Side

\* Not compatible with MB option

## STOPS

### Adjustable Stop\*

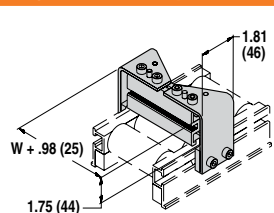

- Slides up and down T-slot length
- Includes metric mounting hardware

Part Number	Description
3076WWM	Adjustable Stop, 2200 & 2300 Series
2460WWM	Adjustable Stop, MB

WW = Conveyor Width Reference

\* Not compatible with high friction belts

\* Not compatible with cleated belt conveyors

### End Stop\*

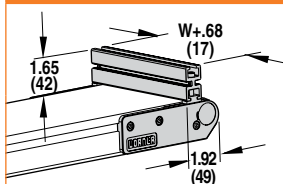

- Anodized aluminum stop
- Includes tail plates and mounting hardware

Part Number	Description
2255WWM	End Stop, 2200 & 2300 Series
2459WWM	End Stop, MB

**Note:** No Gang Drive or cleated belt options

### Roller Conveyor End Stop

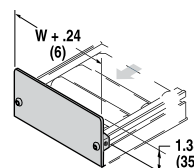

- Includes metric mounting hardware

Part Number	Description
2086WWM	Roller End Stop

Note: Dimensions = in (mm)

Due to the wide variety of drive set ups and applications, point of installation guarding is the responsibility of the end user.



# 2200 & 2300 SERIES: ACCESSORIES

## BRACKETS

### Adjustable Height Bracket\*‡

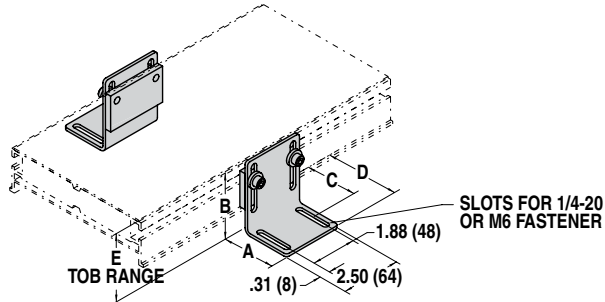

- Provides height adjustment
- (2) Height Ranges
- Includes mounting hardware
- Compatible with 2200 & 2300 Series

Part Number	Description	A	B	C	D	E
201557	2" x 3" Bracket	2 (51)	3 (76)	1.4 (36)	2.4 (61)	1.9 (48) to 3.4 (86)
201558	3" x 5" Bracket	3 (76)	5 (127)	2 (51)	3.4 (86)	3.3 (84) to 5.3 (135)

### Table Top Mounting Bracket\*‡

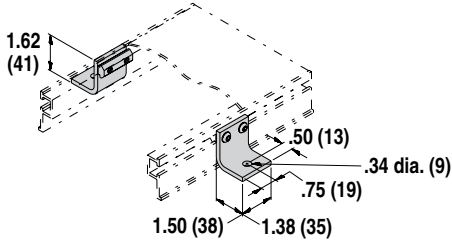

- Includes metric mounting hardware

Part Number	Description
200349M	Table top bracket, 2200 Series
715659	Table top bracket, 2300 Series

‡ = If the discharge end of conveyor is mounted over a table or similar structure, the customer must provide guiding to prevent against possible pinch point.

### Frame Mount Casters\*

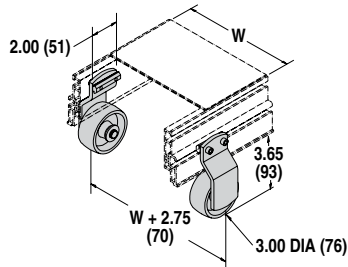

- Includes metric mounting hardware
- Compatible with 2200 & 2300 Series

Part Number	Description
390207	Frame mount casters, pair

### Floor Mount Brackets

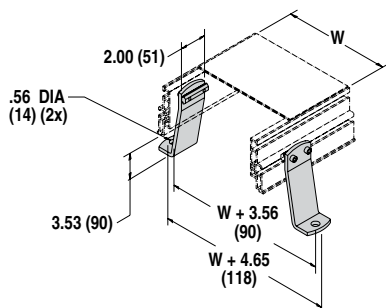

- Includes metric mounting hardware
- Compatible with 2200 & 2300 Series

Part Number	Description
390217	Floor mount brackets, pair

\* Not compatible with MB option

Note: Dimensions = in (mm)

## DRIVE SHAFT ACCESSORIES

### Support Block\*

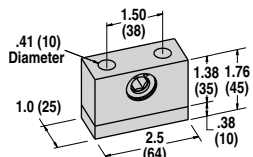

- For 2200 Series Gang Drive Conveyors

Part Number	Description
23-33M	Support Block, 0.38" Hex Shaft

\* Not compatible with MB option

### Solid Coupling, Hex to Hex\*

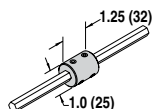

- Includes metric set screws

Part Number	Description
210064M	Solid Coupling, 0.38" Hex to Hex

\* Not compatible with MB option

### Hex Shaft\*

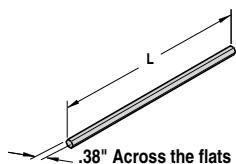

Part Number	Description
23-24SS	0.38" Hex Shaft, stainless steel, 48" (1,219 mm) long
631418	0.38" Hex Shaft, stainless steel, 72" (1,829 mm) long

\* Not compatible with MB option

### Flexible Coupling

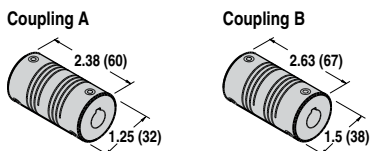

- (A) Includes SAE set screws, (B) metric set screws

Part Number	Description	Coupling
23M29	Flexible Coupling, 12 mm bore x 0.38" hex	B
23M31	Flexible Coupling, 12 mm bore x 12 mm bore	B

### Clear Cover



- Fits 2200 & 2300 light load top mount and standard and heavy load top and bottom mount packages

Part Number	Description
689499M	Clear cover, ordered separately

### Spline Shaft

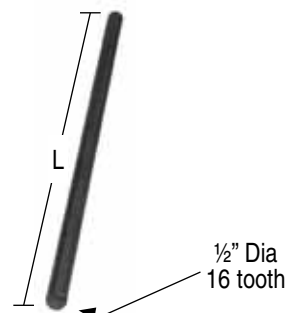

- Compatible with Precision Move Gang Mid Drive

Part Number	Description
202432-04800	1/2" diameter x 16 tooth x 4' long Spline Shaft

## SERVICE ACCESSORIES

### Tool Kit

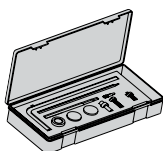

Part Number	Description
2200M	Tool Kit, 2200 & 2300 Series, Metric
2500M	Tool Kit, 2200 Series, Gang Drive

Note: Dimensions = in (mm)

Due to the wide variety of drive set ups and applications, point of installation guarding is the responsibility of the end user.

# 2200 & 2300 SERIES: PART NUMBER REFERENCE

## 2200 & 2300 SERIES: FLAT BELT END DRIVE

2 0 F M WW - LLLL 1 1 0 A PP PP BB - EDSTP

Optional End Stop (-EDSTP) or iDrive (see iDrive options)

Belt Type

Profile (D side):

01 = Lowside      07 = Low to side wiper      13 = Fully adjustable  
 04 = 3" high side      09 = 1/2" high side      14 = Tool-less fully adjustable  
 05 = 1.5" high side      10 = 1/2" UHMW high side

Profile (A side):

01 = Lowside      07 = Low to side wiper      13 = Fully adjustable  
 04 = 3" high side      09 = 1/2" high side      14 = Tool-less fully adjustable  
 05 = 1.5" high side      10 = 1/2" UHMW high side

Motor Shaft Position: A, B, C or D (non-Gang Drive)

Idler Tail Type:

0 = Standard 1.25"      2 = Output shaft D side      4 = Standard 1.25" w/mag  
 1 = Output shaft A side      3 = Nose bar      G = Gang Drive End

Drive Tail Type: 0 = Standard 1.25" 1 = Standard 1.25 Dual Output Drive End G = Gang Drive End

Guide / Mounting Brackets:

- 1 = with tracking cams and mounting brackets
- 2 = V-guide and mounting brackets
- 3 = with tracking cams, no mounting brackets, no return rollers
- 4 = V-guide, no mounting brackets, no return rollers
- 5 = with tracking cams & return rollers, no mounting brackets
- 6 = V-guide & return rollers, no mounting brackets

Conveyor Length Reference: 0150 to 1800

Conveyor Width Reference: 02 to 24

Documentation Language: M = English

Model Type: 2 = 2200 Series F = 2300 Series

Drive Shaft Position

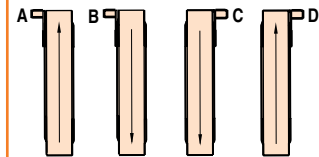

Since belts are being pulled, positions A & D are preferred. Pushing belts (B & C) reduce conveyor load capacity by approximately 66%.

## 2200 & 2300 SERIES: iDRIVE® OPTIONS

FD C P A

Speed Range: A = 7 to 70 FPM      C = 3 to 24 FPM

B = 5 to 50 FPM      D = 1.7 to 17 FPM

Power Supply: P = Power Supply Included N = No power supply

Control Type: S = Separate (only available as no power supply) M = Mounted

Integrated Frame Drive

These reference charts are only provided as a reference and is not intended to be used for the construction of complete part numbers for order placing. Dorner has a full network of trained Distributors and sales staff equipped with our configuring / pricing software who are able to provide complete and accurate quotes for all standard products in a matter of minutes.

For more information about any product or accessory, or to locate a local distributor, go to [www.dorner.com](http://www.dorner.com).

# 2200 & 2300 SERIES: PART NUMBER REFERENCE

## 2200 & 2300 SERIES: FLAT BELT CENTER DRIVE

2 5 F M WW - LLLL 1 1 0 A PP PP BB - EDSTP

**Optional End Stop (-EDSTP) or iDrive**  
(see iDrive options on page 74)

**Belt Type**

**Profile (D side):**

- 01 = Lowside
- 04 = 3" high side
- 05 = 1.5" high side
- 07 = Low to side wiper
- 09 = 1/2" high side
- 10 = 1/2" UHMW high side
- 13 = Fully adjustable
- 14 = Tool-less fully adjustable

**Profile (A side):**

- 01 = Lowside
- 04 = 3" high side
- 05 = 1.5" high side
- 07 = Low to side wiper
- 09 = 1/2" high side
- 10 = 1/2" UHMW high side
- 13 = Fully adjustable
- 14 = Tool-less fully adjustable

**Motor Shaft Position: A, D or E**

**Idler Tail Type:** 0 = Standard 1.25" 2 = Output shaft D side 4 = Standard 1.25" w/mag  
1 = Output shaft A side 3 = Nose bar

**Drive Tail Type:** 0 = Standard 1.25" 2 = D side discharge end  
1 = Output shaft A side 3 = Nose bar

**Guide / Mounting Brackets:**

- 1 = with tracking cams and mounting brackets
- 2 = V-guide and mounting brackets
- 3 = w/ tracking cams, no mounting brackets, no return rollers
- 4 = V-guide, no mounting brackets, no return rollers
- 5 = w/ tracking cams & return rollers, no mounting brackets
- 6 = V-guide & return rollers, no mounting brackets

**Conveyor Length Reference: 0150 to 1800**

**Conveyor Width Reference: 02 to 24**

**Documentation Language: M = English**

**Model Type: 2 = 2200 Series F = 2300 Series**

### Drive Shaft Position

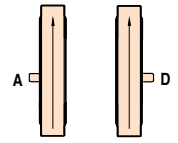

Reversing Belt Direction reduces conveyor load capacity by 66%.

## 2200 & 2300 SERIES: CLEATED BELT END DRIVE

2 C F M WW - LLLL 1 0 1 A PP C H SSSS - FDCPA

**iDrive Option** (see page 74)

**Cleat Spacing**

**Base Belt Material: H = High Friction L = Low Friction**

**Cleat Height: A, B, C, F, G, H, V or J**

**Profile:**

- 01 = Lowside
- 02 = 1/2" cleated guide
- 03 = 1" cleated guide
- 06 = 2 1/2" cleated guide

**Motor Shaft Position: A, B, C or D (non-Gang Drive)**

**Idler Tail Type:**

0 = Standard 1.25" 2 = Output shaft D side G = Gang Drive End  
1 = Output shaft A side 4 = Standard 1.25" w/mag

**Drive Tail Type:** 0 = Standard 1.25" 2 = Standard 1.25 Dual Output G = Gang Drive End

**Guide / Mounting Brackets:**

- 1 = with tracking cams and mounting brackets
- 2 = V-guide and mounting brackets
- 3 = w/ tracking cams, no mounting brackets, no return rollers
- 4 = V-guide, no mounting brackets, no return rollers
- 5 = w/ tracking cams & return rollers, no mounting brackets
- 6 = V-guide & return rollers, no mounting brackets

**Conveyor Length Reference: 0150 to 1800**

**Conveyor Width Reference: 02 to 24**

**Documentation Language: M = English**

**Model Type: 2 = 2200 Series F = 2300 Series**

### Drive Shaft Position

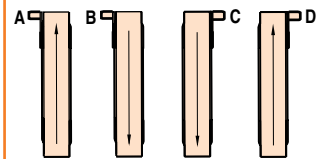

Since belts are being pulled, positions A & D are preferred. Pushing belts (B & C) reduce conveyor load capacity by approximately 66%.

# 2200 & 2300 SERIES: PART NUMBER REFERENCE

## 2200 SERIES: GRAVITY ROLLER

2260 M WW - LLLL - PP / SS

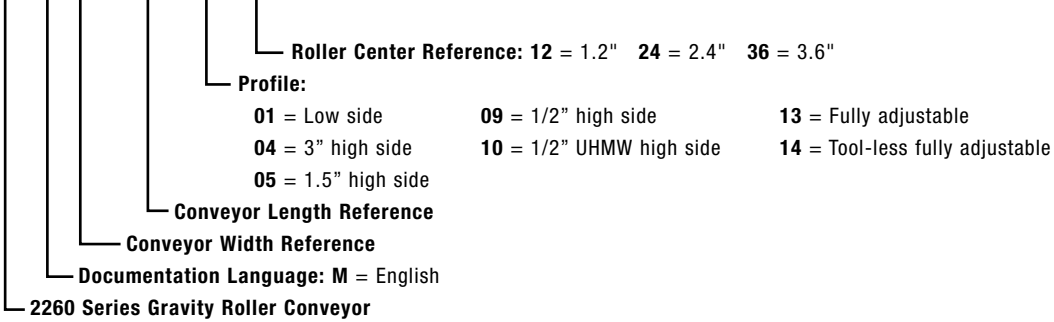

## 2200 & 2300 MB SERIES: FLAT BELT END DRIVE

2 E 2 M WW - LLLL 0 0 0 A PP PP BB - EDSTP

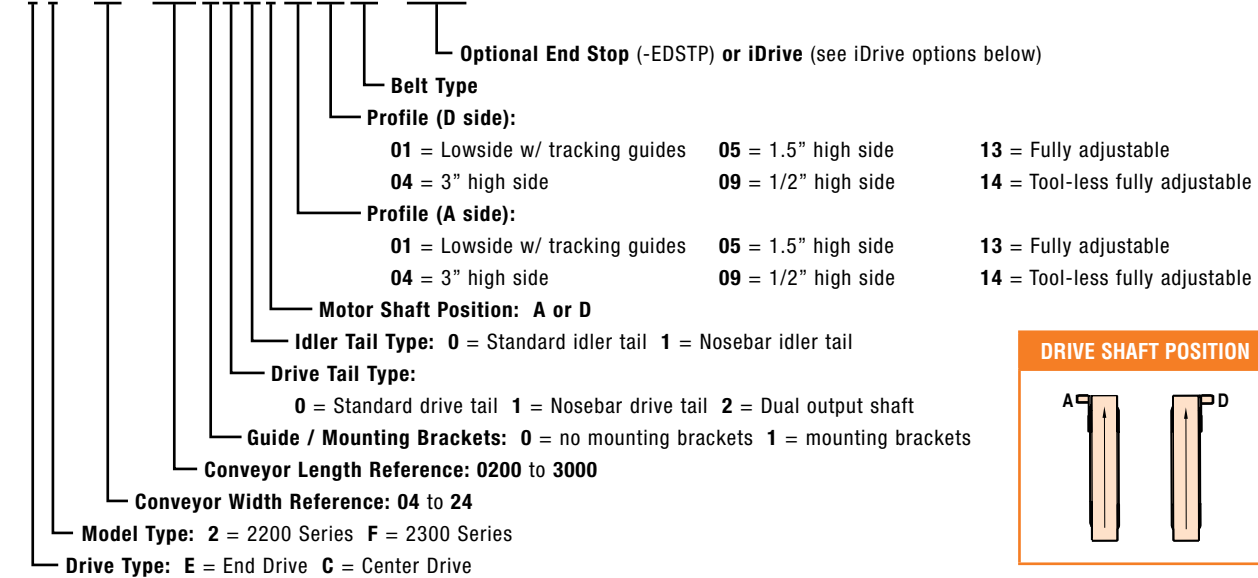

### DRIVE SHAFT POSITION

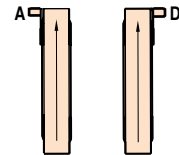

## 2200 & 2300 MB SERIES: CENTER DRIVE MOUNT PACKAGE

2PMC E S WW A - 2828

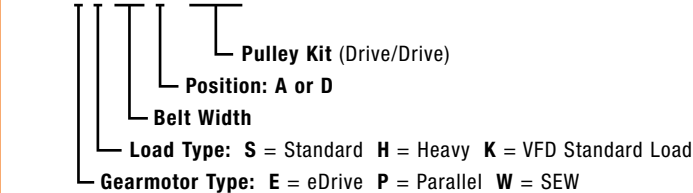

## 2200 & 2300 SERIES: IDRIVE OPTIONS

FD C P A

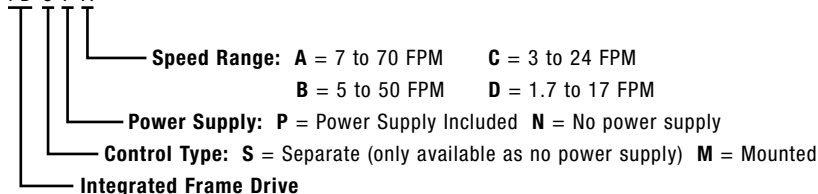

# 2200 & 2300 SERIES: PART NUMBER REFERENCE

## 2200 PRECISION MOVE: STRAIGHT FLAT BELT END DRIVE

2 0 T M WW - LLLL 1 1 0 A PP PP BB - EDSTP

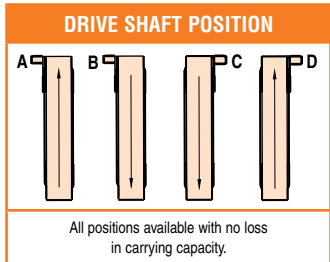
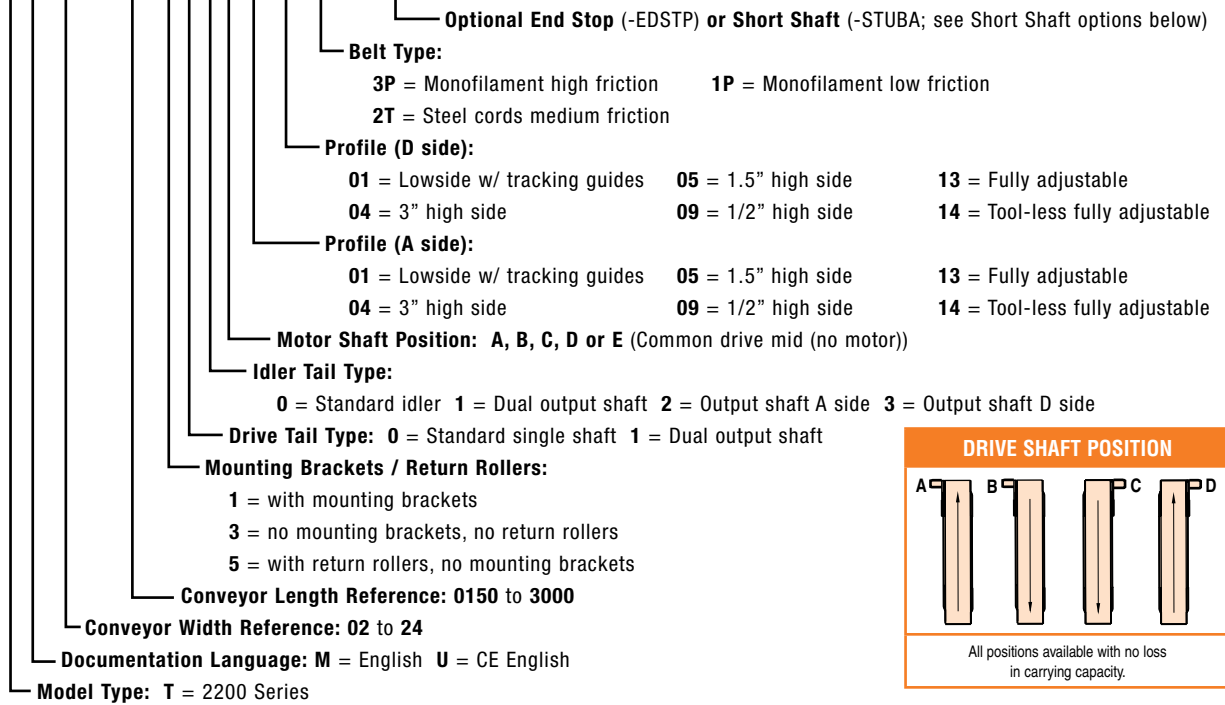

## 2200 PRECISION MOVE: SHORT SHAFT OPTIONS

STUB A

- Stub Shaft Position:**
- A** = A Position
  - B** = B Position
  - C** = C Position
  - D** = D Position
  - E** = Both sides of dual shaft discharge
  - F** = Both sides of dual shaft infeed
  - G** = Both sides of dual shaft on both ends

These reference charts are only provided as a reference and is not intended to be used for the construction of complete part numbers for order placing. Dorner has a full network of trained Distributors and sales staff equipped with our configuring / pricing software who are able to provide complete and accurate quotes for all standard products in a matter of minutes.

For more information about any product or accessory, or to locate a local distributor, go to [www.dorner.com](http://www.dorner.com).

# 2200 & 2300 SERIES: PART NUMBER REFERENCE

## 2200 PRECISION MOVE: CLEATED BELT

2 C T M WW - LLLL 1 1 A PP C H SSSS - STUBA

- Optional Short Shaft (-STUBA; see Short Shaft options, pg 77)
- Cleat Spacing (inch, inch, inch, inch)
- Base Belt Material: 3 = High friction 1 = Low friction
- Cleat Height: A = 0.75" (20mm) B = 1.4" (36mm) C = 2" (52mm)
- Profile: 01 = Lowside 02 = 1" cleated guide 03 = 2" cleated guide
- Motor Shaft Position: A, B, C or D
- Idler Tail Type: 0 = Standard idler 1 = Dual output shaft 2 = Output shaft A side 3 = Output shaft D side
- Drive Tail Type: 0 = Standard single shaft 1 = Dual output shaft
- Guide / Mounting Brackets:
  - 1 = with mounting brackets
  - 3 = no mounting brackets, no return rollers
  - 5 = with return rollers, no mounting brackets
- Conveyor Length Reference: 0150 to 3000
- Conveyor Width Reference: 02 to 24
- Documentation Language: M = English U = CE English
- Model Type: T = 2200 Series

### DRIVE SHAFT POSITION

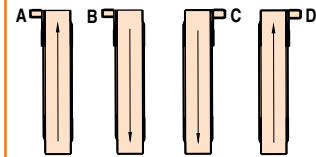

All positions available with no loss in carrying capacity.

## 2200 PRECISION MOVE: MID DRIVE

2 6 T M WW - LLLL 1 1 A PP PP BB - EDSTP

- Optional End Stop (-EDSTP) or Short Shaft (-STUBA; see Short Shaft options, pg 77)
- Belt Type:
  - 3P = Monofilament high friction 1P = Monofilament low friction
  - 2T = Steel cords medium friction
- Profile (D side):
  - 01 = Lowside w/ tracking guides 05 = 1.5" high side 13 = Fully adjustable
  - 04 = 3" high side 09 = 1/2" high side 14 = Tool-less fully adjustable
- Profile (A side):
  - 01 = Lowside w/ tracking guides 05 = 1.5" high side 13 = Fully adjustable
  - 04 = 3" high side 09 = 1/2" high side 14 = Tool-less fully adjustable
- Motor Shaft Position: A, D or G (Gang drive (hollow splined))
- Infeed Tail Type:
  - 0 = Standard idler 1 = Dual output shaft 2 = Output shaft A side 3 = Output shaft D side
- Discharge Tail Type:
  - 0 = Standard idler 2 = Output shaft A side
  - 1 = Dual output shaft 3 = Output shaft D side
- Guides / Mounting Brackets:
  - 1 = with mounting brackets
  - 3 = no mounting brackets, no return rollers
  - 5 = with return rollers, no mounting brackets
- Conveyor Length Reference: 0200 to 3000
- Conveyor Width Reference: 02 to 24
- Documentation Language: M = English U = CE English
- Model Type: T = 2200 Series

### DRIVE SHAFT POSITION

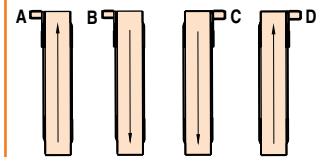

All positions available with no loss in carrying capacity.

These reference charts are only provided as a reference and is not intended to be used for the construction of complete part numbers for order placing. Dorner has a full network of trained Distributors and sales staff equipped with our configuring / pricing software who are able to provide complete and accurate quotes for all standard products in a matter of minutes.

For more information about any product or accessory, or to locate a local distributor, go to [www.dorner.com](http://www.dorner.com).

# 2200 & 2300 SERIES: PART NUMBER REFERENCE

## 2200 & 2300 SERIES: END DRIVE MOUNTING PACKAGES

22 M B P S 06 A - 2828

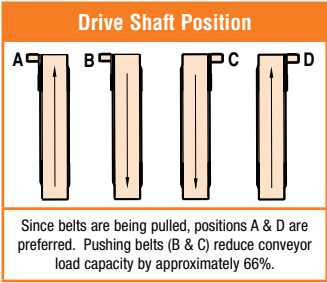
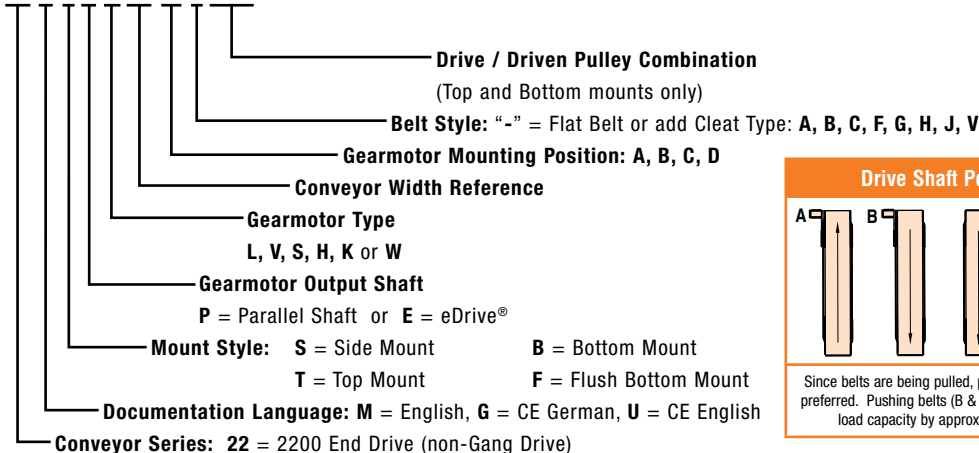

**Example:** 22MBPS06A-2828

**Description:** Bottom mount package with English documentation for 6" (152) wide 2200 series end drive conveyor. Configured for a parallel shaft, Standard load motor in the A1 mount position with a 28:28 drive / driven pulley combination.

## 2200 & 2300 SERIES: CENTER DRIVE MOUNTING PACKAGES

22 M 2 P S 06 A - 3232

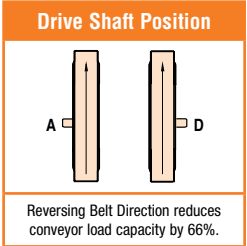
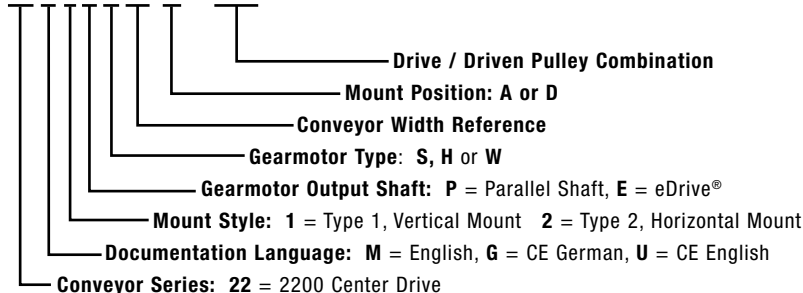

**Example:** 22M2PS06A-3232

**Description:** 2200 Series Horizontal Center Drive Mounting Package with English documentation for a parallel shaft standard load gearmotor mounted in the A position, with a 32:32 drive / driven pulley combination, on a 6" (152) wide conveyor.

These reference charts are only provided as a reference and is not intended to be used for the construction of complete part numbers for order placing. Dorner has a full network of trained Distributors and sales staff equipped with our configuring / pricing software who are able to provide complete and accurate quotes for all standard products in a matter of minutes.

For more information about any product or accessory, or to locate a local distributor, go to [www.dorner.com](http://www.dorner.com).



# 2200 & 2300 SERIES: PART NUMBER REFERENCE

## 2200 MB SERIES: END DRIVE MOUNTING PACKAGES

2P M B P S 06 A - 2828

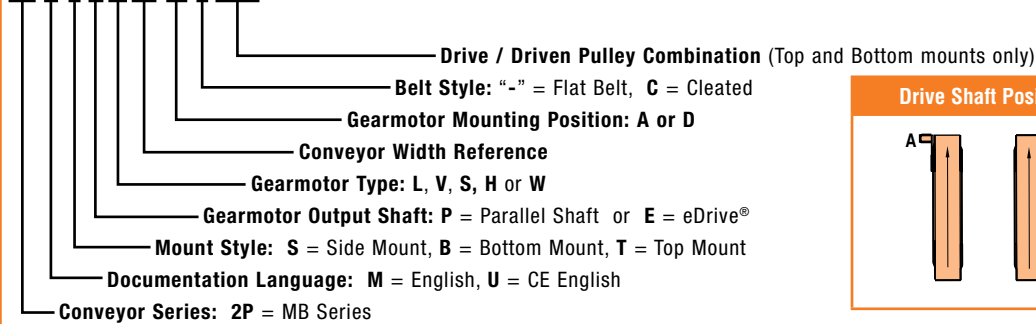

### Drive Shaft Position

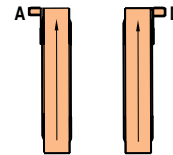

**Example:** 2PMBPS06A-2828

**Description:** Bottom mount package for 6” (152) wide MB conveyor, standard load parallel shaft gearmotor in the A mount position with a 28:28 drive / driven pulley combination with English documentation.

## 2200 PRECISION MOVE: GANG DRIVE SIDE MOTOR MOUNTING KIT

22MG E S - WW Q GG A

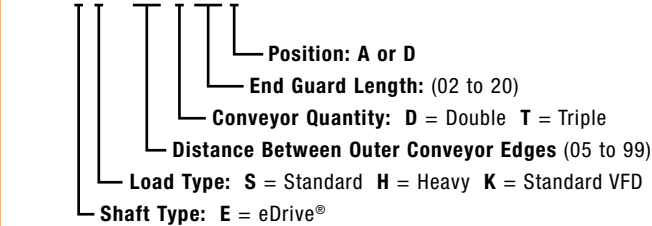

## 2200 PRECISION MOVE: MID DRIVE MOUNTING KIT

22M6 P E S A - DVDR

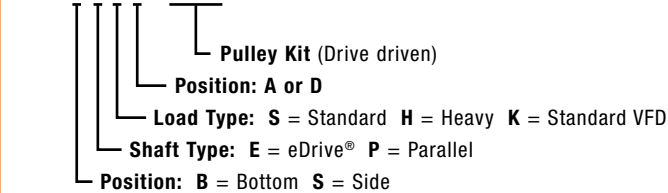

These reference charts are only provided as a reference and is not intended to be used for the construction of complete part numbers for order placing. Dorner has a full network of trained Distributors and sales staff equipped with our configuring / pricing software who are able to provide complete and accurate quotes for all standard products in a matter of minutes.

For more information about any product or accessory, or to locate a local distributor, go to [www.dorner.com](http://www.dorner.com).

# 2200 & 2300 SERIES: PART NUMBER REFERENCE

## 2200 PRECISION MOVE: HIGH TORQUE END DRIVE MOTOR MOUNTING PACKAGE

22 M S E S A T

- Position: A, B, C or D
- Gearmotor Type: S = Standard Load H = Heavy Load K = Standard Load VFD
- Gearmotor Output Shaft: E = eDrive® 90°
- Mount Style: S = Side
- Language: M = English

## 2200 & 2300 SERIES: COMMON MOUNT KIT

39MCM WW - #

- Number of Conveyors
- Width Stand

Example: 39MCM-244

## 2200 & 2300 SERIES: SUPPORT STANDS

S 9 M T T WW - HH(min) HH(max) F A

- Feet or Casters (not available for multi tier stands)
  - F = fixed foot pad
  - C = total lock swivel caster
- Height Reference
- Width Reference
- Stand Type
  - LH = short stand
  - T1 = multi tier stand base
  - SP = single post
  - A2 = 2200 A-Frame mount
  - FH = fixed height
  - T2 = multi tier stand tier
  - PS = pillar support
  - AF = 2300 A-Frame mount
  - AH = adjustable height
  - FT = tall fixed\*
  - QA = quick adjust
  - FA = fully adjustable
  - AT = tall adjustable\*
  - AD = heavy load drive mount
- Documentation Language: M = English
- Stand Style
  - 3 = 2-legged stand, 4 = Single post or pillar style

EXAMPLE: 39MAH12-2126CP

**Note:** Due to the wide variety of conveyor and stand options along with possible configurations, stability is final setup of the responsibility of the end user.  
 \*Tall stands are required when the stand width is 3.5 times the stand height.

These reference charts are only provided as a reference and is not intended to be used for the construction of complete part numbers for order placing. Dorner has a full network of trained Distributors and sales staff equipped with our configuring / pricing software who are able to provide complete and accurate quotes for all standard products in a matter of minutes.

For more information about any product or accessory, or to locate a local distributor, go to [www.dorner.com](http://www.dorner.com).