

# **bgl Series**

counterbalanced lift truck

**BLUE GIANT®**

The BGL Series combines the advantages and versatility of a sit-down fork lift while providing the economy and efficiency of a walkie stacker.

The BGL is the perfect machine for just-in-time distribution and manufacturing operations, general loading dock area and warehouse use and for one company - one truck businesses that require economical material handling versatility.

## **CAPACITIES**

- BGL-22 - 2,200 lb at 24" load center
- BGL-30 - 3,000 lb at 24" load center
- BGL-40 - 4,000 lb at 24" load center

## **LIFT HEIGHTS**

- 63 inches
- 118 inches, 130 inches, 150 inches
- 160 inches, 172 inches

## **OPERATION/CONTROLS**

- Ergonomic design with butterfly forward/reverse travel controls
- Large safety reversing button propels truck away from operator and sounds horn if contact with operator is made
- Automatic "dead man" braking with power cut off switch when brake is applied

## **DRIVE SYSTEM**

- Smooth, stepless acceleration and controlled plug braking
- Battery efficiency and truck use capability between charges increases by up to 50% over resistor style trucks
- Diagnostic test and fault information
- Sealed gear reducer / brake system with internal multi-disc brakes in oil bath that virtually eliminates conventional brake safety problems such as adjustments, drum and/or shoe replacement
- All gear and brake components protected from exposure to moisture and dirt, packaging, strapping etc.
- All gears are precision ground helical type and drive axle mounted on precision tapered roller bearings
- Solid state throttle mechanism
- Controller is programmable to allow custom speed and acceleration settings
- Heavy duty motor, gear pump, check and relief valve
- Lift, lower and tilt functions feature manual lever controls for load feathering capabilities

## **ELECTRICAL SYSTEM**

- 24 volt
- On/Off key switch
- Fused drive and control circuits
- Series wound high torque maintenance free drive motor, Class H insulation and heavy duty motor contactors with replaceable tips
- Dashboard mounted emergency power disconnect button



## **FORKS/CHASSIS**

- Heavy duty nested I-beam mast design units
- Dual leaf style lifting chains with 5:1 safety factors
- 42" long forged forks
- ITA Class II hook type mounting carriage
- 48" high load backrest
- 2° forward, 8° back tilt mast
- Single tilt cylinders on 2,200 lb and 3,000 lb 2 stage units
- Twin tilt cylinders on 3,000 lb 3 stage and all 4,000 lb models

## **WHEELS**

- Press-on 10" x 4" red poly, taper mounted hub design for easy servicing
- Poly load wheels 10 1/2" x 5"

## **OPTIONAL EQUIPMENT**

- Special application tires
- Other fork sizes
- Battery gauges
- U.L EE rating

# Specifications

CHARACTERISTICS	Manufacturer	BLUE GIANT			
	Model	Manufacturer's designation	BGL-22	BGL-30	BGL-40
Capacity	Q Rated capacity	2,200 lb	3,000 lb	4,000 lb	
Load center	C Distance (Refer to charts)	24"			
Power type	Electrical	24 volt			
Control type	Hand, Pedestrian, Ride-On	Hand / Pedestrian			
Tire equipment	Drive end / Load end	Poly / Poly			
Wheels	Number (x=driven) Drive end/Load end	1 x + 0 / 2			
DIMENSIONS	Lift	H3 Lift	Refer to charts		
		Lift and fork height	Refer to charts		
	Forks	H2 Free lift	Refer to charts		
		S Forks lowered	3"		
		I Length standard	42"		
		Length optional	36", 48"		
		B3 Fork adjustment	8" - 31.25"		
	Overall dimensions	E Fork width x Thickness	4" x 1.75"		
		L Length	107"		
		L2 Length	65"		
B Width		38"			
Turning radius	H1 Lowered mast height	Refer to charts			
	H4 Raised mast height	Refer to charts			
90° Stacking aisle	WA	58"			
PERFORMANCE	Speeds	Traveling - with load	2.0 mph	1.7 mph	1.6 mph
		Traveling - without load	3.0 mph	3.0 mph	2.6 mph
		Lifting - with load	39 fpm	38 fpm	31 fpm
		Lifting - without load	59 fpm		
		Lowering - with load	34 fpm	16 fpm	13 fpm
		Lowering - without load	25 fpm		
	Grade clearance	5%			
LOAD	Dead weight	Excluding battery	4,000 lb	4,500 lb	5,000 lb
	Axle loading	Loaded - drive end	10%	10%	4%
Loaded - load end		90%	90%	96%	
CHASSIS	Tires	Quantity - Drive end / Load end	1 / 2		
		Dia. x width - Drive end	10" x 4"		
		Dia. x width - Load end	10" x 5"		
	Wheel base	Y Distance between wheels	46.25"		
	Ground clearance	Bumper to floor/Mast to floor	4" / 2"		
Track	31.5"				
Service brake	Mechanical				
Parking brake	Automatic				
POWER / DRIVE UNIT	Battery	Type	Wet		
		Voltage / AH	24 / 510		
		Battery compartment L x W x H	13.25" x 32" x Open		
	Electric motors	Drive motor	1 hp		
Lift motor		6.93 hp			
Drive control	Type	Solid state			
	Stages forward / reverse	Variable			
Transmission	Type	Geared			
DOWNRATING	Capacity	130"	-	-	3,700 lb
		150"	-	-	3,500 lb
		160"	2,000 lb	2,850 lb	3,400 lb
		172"	-	2,700 lb	-

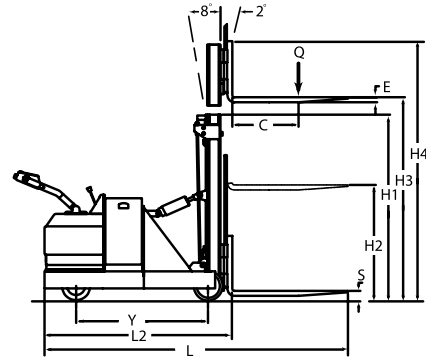

### MAST SPECIFICATIONS

MODEL	LIFT	FREE LIFT	STAGES	LOWERED MAST HEIGHT	RAISED MAST HEIGHT
	H3	H2		H1	H4
BGL-22/30/40	63"	63"	1	78"	83"
BGL-22/30/40	118"	8"	2	78"	138"
BGL-22/30/40	130"	8"	2	83"	150"
BGL-22/30/40	130FF"	**43"	2	83"	150"
BGL-22/30/40	150"	8"	2	93"	170"
BGL-22/30/40	160"	8"	3	78"	180"
BGL-30	172FF"	**43"	3	83"	192"

\*\* Free lift including load backrest; increases to 68" without backrest

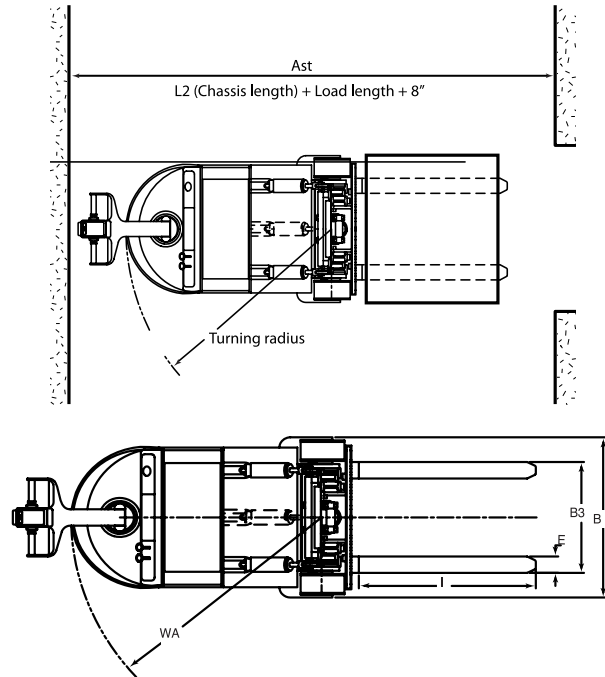

85 Heart Lake Road South  
 Brampton, Ontario, Canada L6W 3K2  
 Phone: 905-457-3900 • Fax: 905-457-2313  
 www.BlueGiant.com

AUTHORIZED DISTRIBUTOR

## BLUE GIANT EQUIPMENT CORPORATION

BLUE GIANT offers a full line of Loading Dock Equipment including Dock Levelers, Vehicle Restraints, Dock Seals and Shelters and Material Handling Solutions. Concurrent with our continuing product improvement program, specifications are subject to change without notice. Please contact BLUE GIANT for latest information. Some features illustrated may be optional in certain market areas.