

E30 Electric Pallet Truck

Upgrade your hand pallet truck. No more pushing, pulling and pumping.

CAPACITY

3000 lbs (1361 kgs)

BATTERY—CH

Integral 24-volt 65AH maintenance free batteries with matching 110V AC plug-in automatic charger.

SPEED

Curtis® transistor speed control

TRAVEL SPEED—VARIABLE

2.5 mph empty
2.15 mph loaded

TIRES/WHEELS

DRIVE WHEEL

8.26" x 2.76" (210 mm x 70 mm) polyurethane

LOAD WHEELS

2.36" x 3.15" (60 mm x 80 mm) polyurethane

HYDRAULICS

Pump motor with relief valve protects system from overloading.

ELECTRICAL

Advanced Curtis® drive controller provides smooth step-less acceleration with infinitely variable speed control. Anti-rollback feature delivers maximum power when required for up-hill or down-hill gradients.



e truck

BRAKES

Electromagnetic disc brake connected to drive shaft. Adjustable neutral braking, plugging, and regenerating braking are standard. "Dead-man" emergency brake with power cut-off.

CONTROLS

Travel lift and lower functions are located in the ergonomic operator handle designed to allow operation with either hand. Wrap around hand guard, reversing switch, dual "butterfly" thumb control, and horn are standard.

TRANSMISSION

Durable long life low noise gearbox.

SERVICEABILITY

Removal of two piece power head cover exposes major components for inspection and maintenance.

STANDARD EQUIPMENT

- Curtis® Transistor Travel Controller
- "Butterfly" Travel Thumb Control
- Key switch and horn button
- Battery Discharge Indicator (BDI)



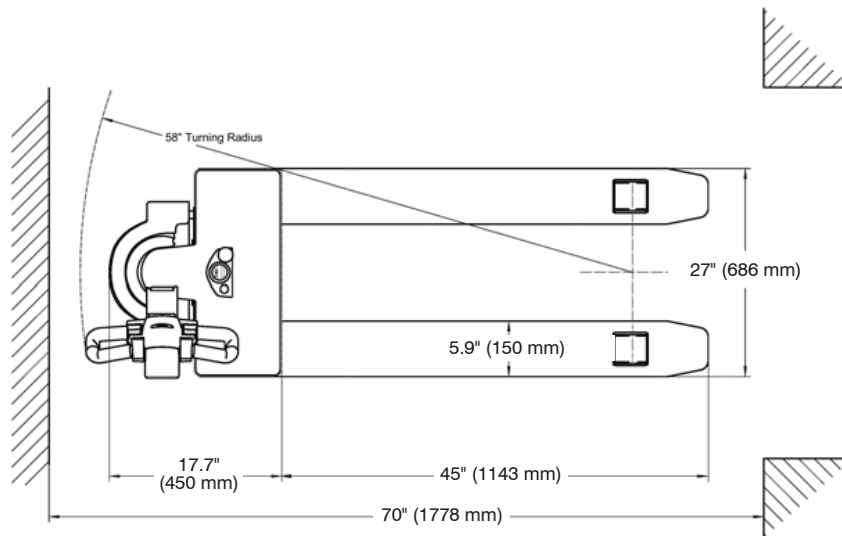
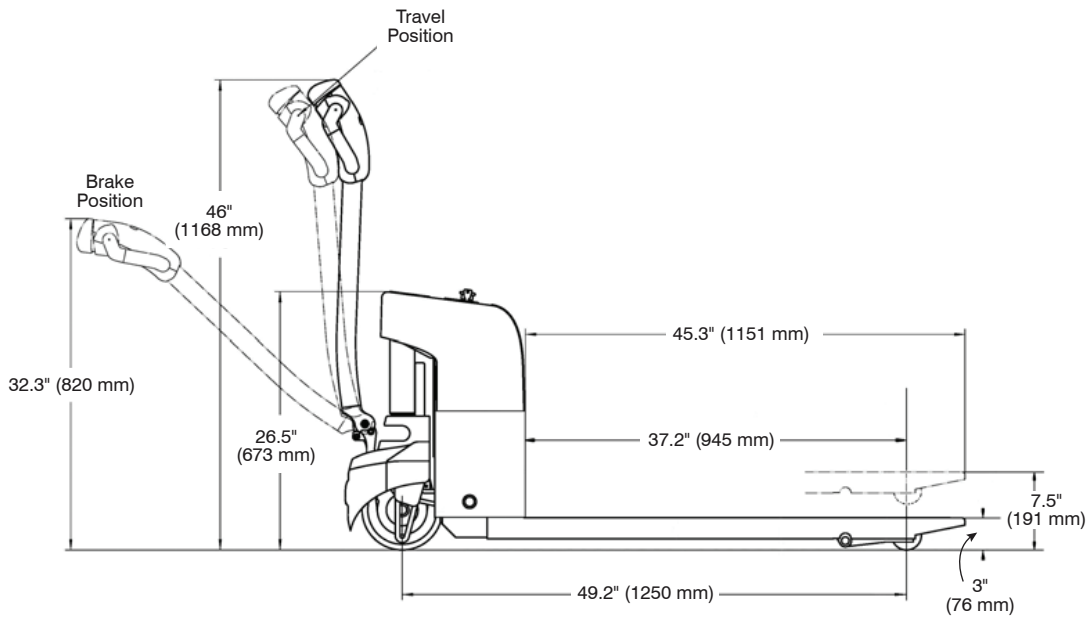

85 Heart Lake Road South
 Brampton, Ontario, Canada L6W 3K2
 Phone: 905-457-3900 • Fax: 905-457-2313
 www.BlueGiant.com



AUTHORIZED DISTRIBUTOR

BLUE GIANT MATERIAL HANDLING DIVISION

BLUE GIANT offers a full line of Loading Dock Equipment including Dock Levelers, Vehicle Restraints, Dock Seals and Shelters and Material Handling Solutions. Concurrent with our continuing product improvement program, specifications are subject to change without notice. Please contact BLUE GIANT for latest information. Some features illustrated may be optional in certain market areas.