

D40

Ultra compact design is the ideal solution for lift gate and local delivery applications.

CAPACITY

4000 lbs (1814 kg)

INTEGRAL BATTERY / CHARGER

(2) 12-Volt Absorbed Glass Matt (AGM) 85AH maintenance free batteries with 10 AMP 110VAC plug-in automatic charger.

TRAVEL SPEED

24-Volt ZAPI ACO Travel Controller
Variable from 0 mph to 3.6 mph empty
Variable from 0 mph to 3.3 mph loaded

WEIGHT

600 lbs (272 kg) with battery and charger.

TIRES

DRIVE

9" x 3" (229 x 76mm) polyurethane

STABILITY CASTERS

3.3" X 1.9" (84 x 48mm) polyurethane

LOAD

2.9" x 3.5" (74 x 89mm) polyurethane

TILLER ARM CONTROLS

Travel, lift, and lower functions are located in the ergonomic operator handle. All operator controls are accessible without having to lift the hand from the handle.

Angle grips are designed to allow easy operation with either hand. Wrap around guard, reversing switch, thumb control, and horn are standard. Low mounted tiller arm offers excellent operator comfort and minimum steering effort. Gas assisted spring tiller handle gently returns to vertical position when released.

Crawl speed function with steer handle at 15° back-tilt from vertical allows for ease of use in tight areas.

ELECTRICAL

Electric braking, quick disconnect EPD power cut off, key switch and battery discharge indicator are standard equipment.

HYDRAULICS

Lift cylinder has hard chrome plated rods. Pump unit including motor, solenoid, gear pump, and pressure compensated lowering valve are mounted high in the power compartment for ease of service.



DRIVE UNIT

Vertically mounted AC drive motor is direct mounted to gear housing. Oil bathed hypoid bevel gear drive train with tapered roller bearings transfers power to axle.

State of the art optimized gear technology supplies advantages such as minimal envelope circle, zero maintenance, low noise level, high efficiency and high performance.

Electromagnetic brake is mounted on motor armature shaft multiplying the braking power through the transmission. Brake is applied when control arm is in the vertical or horizontal handle position. System features anti-roll back and neutral braking.

ACCESSIBILITY

Water resistant removal three piece power head cover exposes major components and maintenance free AGM batteries for inspection and maintenance.

OPTIONAL EQUIPMENT

- Rubber lug drive tire
- 48" tall load back rest
- 60" tall load back rest
- Fork width - 22"
- Fork length - 36"
- Tool tray with load restraint
- Stability casters

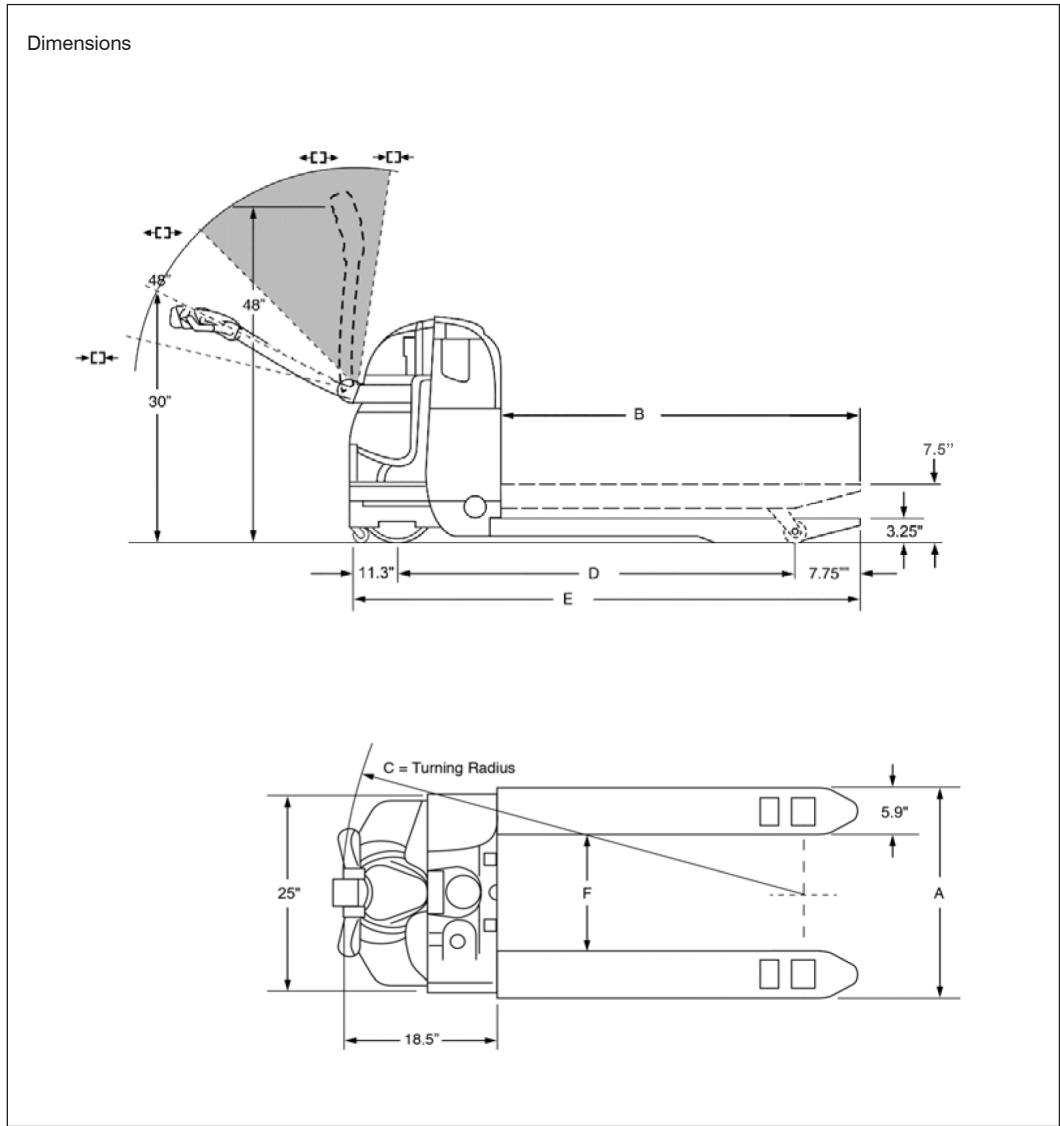

Battery discharge indicator, key switch, emergency power disconnect and built-in automatic battery charger.



Ergonomic Operator's Handle

Gradeability	
Without Load	10%
With Load	6%
Travel - Variable	
Empty	0 to 3.6 mph
Loaded	0 to 3.3 mph

Model#	Forks		Actual Fork Width		Actual Fork Length		Turning Radius		Wheelbase		Overall Length		Inside Fork Width		Weight	
			A		B		C		D		E		F			
Fork Dimension: 27" Wide			in	mm	in	mm	in	mm	in	mm	in	mm	in	mm	lbs	kgs
D40	27" x 36"	686 x 914mm	27	686	33	838	45.5	1156	32.95	837	52	1321	15.2	386	635	288
	27" x 48"	686 x 1219mm			45	1143	57.5	1461	51.25	1302	64	1626			650	295
Fork Dimension: 22" Wide																
D40	22" x 36"	559 x 914mm	21.5	546	33	838	45.5	1156	32.95	837	52	1321	9.7	246	635	288
	22" x 48"	559 x 1219mm			45	1143	57.5	1461	44.95	1142	64	1626			650	295

*Estimated shipping weight with (2) battery.